



Professional Sound Reinforcement Solutions

85 YEARS+

SINCE 1940



Hallmark of Reliability!

Product Catalogue 2026-27

NOSTALGIA

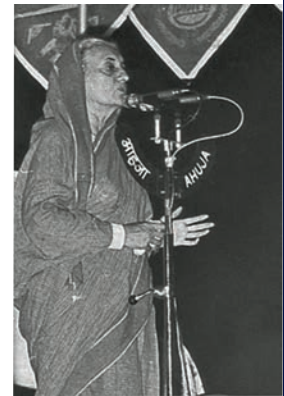
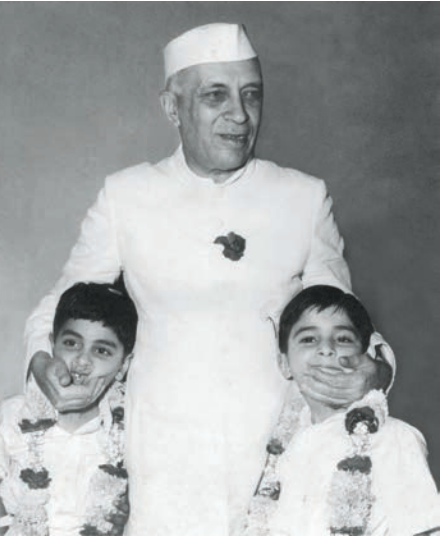



86 Years, and going strong !

A century beckons and waits with bated breath.

From a handful of products in the 1940s, to an all encompassing product line up today, AHUJA remains the undisputed leader in Public Address and Professional Audio in India, & among the most admired the world over.

True to its commitment to the tradition of developing and introducing new products in sync with the emerging needs of the market place, Ahuja feels proud to present this new edition of catalogue 2026-27.

This is also the time to reiterate our gratitude to our valued users and patrons whose support and feedback have continuously motivated us to stretch ourselves and exceed our limits – to not only meet, but surpass your expectations.

Wishing you all the very best !

Ahuja Group

Mr. A.N. Ahuja
Founder Ahuja Group
1916-2007



RESEARCH & DEVELOPMENT

The Ahuja Research and Development Centre gained recognition from the Government of India in 1976, and takes pride in developing products known to perform with absolute reliability even in the most extreme operating & climatic conditions.

COUNTRY WIDE SALES NETWORK AND WORLD WIDE EXPORTS

In India AHUJA products are sold through a network of over 600 retailers. AHUJA products are the preferred choice of discerning users in 50 Countries in 5 Continents.

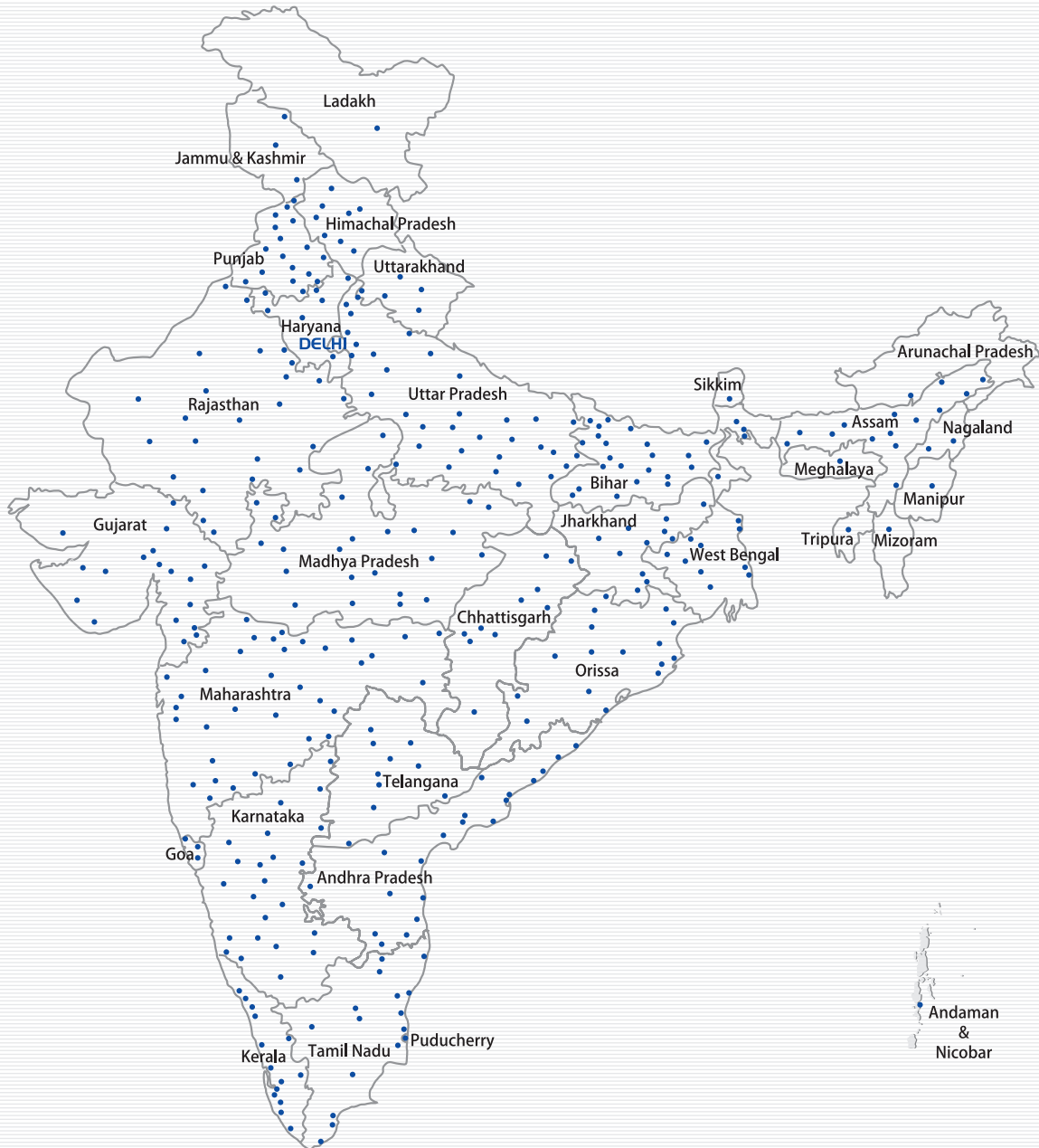

AHUJA PRODUCTS ARE EXPORTED AND SOLD IN 50 COUNTRIES

- Asia: Bangladesh | Bhutan | Myanmar | Nepal | Singapore | Sri Lanka | Thailand | Vietnam
- Middle East: Bahrain | Iraq | Jordan | Kuwait | Lebanon | Oman | Qatar | Saudi Arabia | Syria | U.A.E. | Yemen
- Europe: Austria | France | Germany | Italy | Norway | Poland | Spain | U.K.
- Africa: Algeria | Djibouti | Egypt | Ethiopia | Ghana | Kenya | Libya | Malawi | Mauritius | Morocco | Mozambique | Nigeria | Senegal
Somalia | South Africa | Sudan | Tanzania | Uganda | Zambia
- Oceania: Australia | Fiji
- Americas: Trinidad and Tobago | U.S.A.



An ISO 14001:2015 Company
An ISO/IEC 27001:2013 Company



An ISO 9001:2015 Company

AHUJA'S PIONEERING EFFORTS

EXPORT EXCELLENCE AWARD



Mr. Sandeep Ahuja, Sr. Vice President, (4th from right) & Mr. S. Madan, Director, Intl. Trade (4th from left) receiving the National Export Excellence Award in 2024 presented to Ahuja Radios by Electronics & Computer Software Export Promotion Council.

EXCELLENCE IN ELECTRONICS & IT



Mr. Vikram Ahuja, Vice President, Ahuja Radios, receiving the Award from the then Minister for Information Technology, in recognition of Excellence in Electronics & IT, for the year 2007-2008.

NATIONAL QUALITY AWARD



Mr. Sandeep Ahuja, Sr. Vice President, Ahuja Radios, receiving the National Quality Award in October 2006 from Sh. Pranab Mukherjee, the then Defence Minister.

AWARD FOR LIFETIME ACHIEVEMENT



Mr. A.N. Ahuja, Founder President, Ahuja Radios, receiving the Lifetime Achievement Award from Sh. Balram Jakhar, Ex-Speaker, Lok Sabha, in 2004.

AWARD FOR HIGHEST EXPORT



Mr. A.N. Ahuja, Founder President, Ahuja Radios, New Delhi, receiving the Award from Sh. Arun Shourie, the then Minister of Communication and Information Technology in recognition of Highest Export, in 2002.

AWARD FOR HIGHEST EXPORT



Mr. N.S. Ahuja, Partner, Prosound Products receiving the Award from Sh. Arun Shourie, the then Minister of Communication and Information Technology in recognition of Highest Export, in 2001.

AWARD FOR EXCELLENCE IN ELECTRONICS



Mr. N.S. Ahuja, President, Ahuja Radios, receiving the Award from Sh. Pramod Mahajan, the then Minister for Information Technology in recognition of Excellence in Electronics, for 1999-2000.

AWARD FOR EXCELLENCE IN EXPORT



Mr. Sandeep Ahuja, Sr. Vice President, Ahuja Radios, receiving the Award for Excellence in Exports. The Prestigious Award from the Computer & Software Export Promotion Council was presented by Sh. Pramod Mahajan, the then Minister for Information Technology, for 1999-2000

AWARD FOR EXCELLENCE IN EXPORT



Mr. Arjun Ahuja, Vice President, Ahuja Radios, receiving the Award from Sh. Pramod Mahajan, the then Minister for Information Technology, for 1998-1999.

AWARD FOR HIGHEST EXPORT



Mr. A.N. Ahuja, Founder President, Ahuja Group, receiving the Award from the then Prime Minister, Sh. Atal Behari Vajpayee, for Highest Export in Consumer Electronics, for 1997-1998.

AWARD FOR EXCELLENCE IN EXPORT



Mr. Vikram Ahuja, Vice President, Ahuja Radios, receiving the Award from the then Prime Minister, Sh. Atal Behari Vajpayee, for Excellence in Export in Consumer Electronics, in 1997.

AWARD FOR EXPORT PERFORMANCE



Mr. Pradeep Ahuja, Partner, Prosound Products, Seepz, Mumbai receiving the Award from the then Minister for External Affairs, Sh. Pranab Mukherjee, for Outstanding Export Performance, in 1995-1996.

Contents

Conference Systems

DCW-8500 Series.....	8
CM-7000 Series.....	10
CM-5000 Series.....	12

Amplifiers

Quad Channel Class D Power Amplifiers	16
Dual Channel Class D Power Amplifiers.....	17
Dual Channel Power Amplifiers.....	19
Two Zone PA Power Amplifiers	24
Two Zone PA Mixer Amplifiers.....	25
Power Amplifiers.....	27
PA Power Amplifiers.....	28
PA Mixer Amplifiers.....	30
Vehicle Amplifiers.....	35
Installation Amplifiers.....	37
Audio Splitters.....	38

Amplifiers with built-in Digital Player

Dual Channel Power Amplifier with Digital Player	40
Power Amplifiers with Digital Player.....	41
Two Zone PA Mixer Amplifiers with Digital Player.....	42
PA Mixer Amplifiers with Digital Player	44
Digital Player/Recorder	48

Intelligent Paging Systems

Intelligent Paging Systems.....	50
---------------------------------	----

Mixers & Processors

Audio Mixers.....	54
Audio Effect Processors.....	62

Microphones

Microphones.....	64
Headband Microphones.....	70
PA Wireless Microphones.....	71
Gooseneck Microphones.....	77
Wireless Desktop Microphone	78
Paging Microphones.....	78
Phantom Microphones.....	79
Special Purpose Microphones.....	80
Connecting Cable for Smartphones	80

Audio Interface

Audio Interface.....	82
----------------------	----

Speakers

PA Driver Units	84
PA Horn Speakers	84
Low Impedance PA Horn Speakers.....	85
100V PA Horn Speakers.....	86
Music Horn Speaker	87
PA Horn Speaker for Vehicles.....	87
PA Horns	88
Diaphragms.....	88
Column Speakers.....	88
Ceiling Speakers.....	90
2-Way Ceiling Speakers	94

Wall Speakers.....	95
2-Way Premium Wall Speakers.....	97
2-Way Compact Wall Speakers	98
Special Purpose Speakers	100
Speaker Volume Controllers.....	100
Cabinet Loudspeakers	103
Cabinet Loudspeaker - Stage Monitor	112
PA Active Loudspeaker - Stage Monitor	114
Moulded Cabinet Loudspeakers.....	115
PA Active Loudspeaker - Subwoofer	116
Cabinet Loudspeakers - Subwoofer.....	117
Line Array Loudspeakers.....	125
PA Speakers.....	128
PA Speakers - Neodymium	136
PA Drivers	137
PA Horn Driver.....	137
PA Drivers Diaphragms.....	138
PA Piezo Horn Tweeters	138
Crossover Networks - Active.....	139
Passive Crossovers	139
Loudspeaker Management System.....	142

Portable PA

Bi-Amp PA Active Loudspeakers	144
PA Amplifier Sets	149
2-Way Array Active Loudspeakers	157
Sound Lectern	158
PA Megaphones.....	159

Counter Communication Systems

Counter Communication Systems	160
-------------------------------------	-----

Microphone and Speaker Stands

Microphone Stands	162
Speaker Stands and Brackets.....	162

PA Fundamentals

PA Fundamentals.....	163
INDEX	165



EU-70	11
FMX-112DP	59
SPX-2010.....	111
SWT-1310.....	119
ALA-9000	126
ALX-15000M	127
Diaphragm HD44-60	138
Diaphragm HD51-80	138
Diaphragm HD74-120	138
ALIVE 515.....	144
ALIVE 512.....	145
ALIVE 510.....	146
BTA-1010	150
NBA-112B.....	156



Hallmark of Reliability!

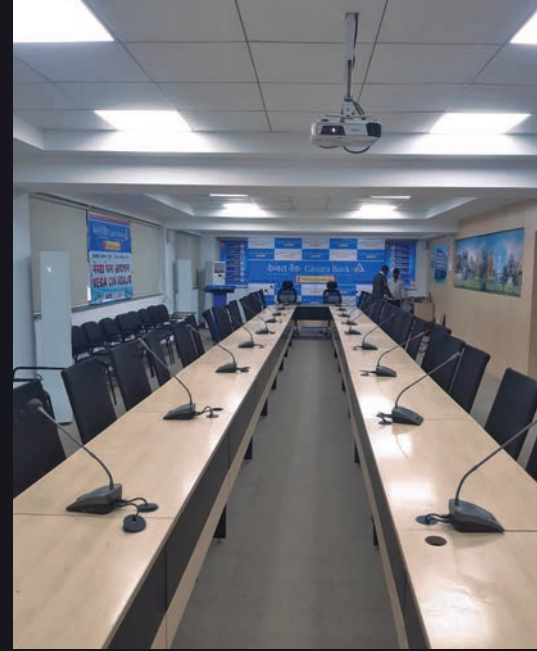

Conference Systems

User friendly, feature laden & simple to install ! Attractive appearance & impeccable speech clarity !

The AHUJA conference systems provide an easy and much needed sound reinforcement solution for all meetings & conventions.

Applications

Auditoriums | Board Rooms | Seminar Halls | Conference Halls

Wireless Conference Systems

DCW-8500 Series



The DCW-8500 Digital UHF Wireless Conference System is a highly flexible, feature laden system ideally suited for the most demanding conference room applications. It features excellent sound quality for highly intelligible and noise free communication.

Secure and reliable wireless design for convenient installation. DCW Series Wireless Conference System is ideal for a variety of Corporate, Educational and Hotel Conference Room applications. The system can be installed with minimal wiring, thus not affecting the decor of the room.

Chairman & up to 255 Delegate Units can be connected in one system. Up to 16 systems can be installed in the same building. The system can be operated in various modes : Chairman Only / Chairman Free (with LIMIT and FIFO options). Built-in feedback suppressor to reduce feedback and howling. Built-in USB Recording facility is available. Software based digital signal processing facility. The system supports automatic Video Camera Tracking from one or multiple cameras, using a separate Video Tracking Unit. Power Supply 3.7V/1450mAh rechargeable battery. Type C charging port are provided.

DCW-8503R HOST UNIT



- Elegant and stylish looks.
- Multi colour display to show the Room ID, mode of operation, number of units, battery status for units etc.,
- Auto power OFF for units when Host Unit is switched OFF.
- Supports DSP software through PC connectivity.
- Host unit is 482.6 mm (19") rack mountable in 2U space.
- Power Supply: 12V DC using AC Adaptor.
- Host unit should be used together with DCW-8501C Chairman Unit and DCW-8502D Delegate Unit.
- Mix Out available for connecting an external amplifier.



DCW-8501C CHAIRMAN UNIT

DCW-8502D DELEGATE UNIT

- Attractive and well contoured housing for superior appearance.
- Multi Colour Display shows the Microphone ID, Battery Level, Room ID etc.,
- Microphone Indicator Ring LED.
- Individual volume buttons to adjust the microphone pickup level.
- Power Supply: 3.7V/1450mAh rechargeable battery. Type C charging port is provided.
- Both units can be used with LGM-20 or SGM-40 Microphone. Either microphone can be purchased as separate unit.
- Maximum of 4 Delegate Units and 1 Chairman Unit can be switched ON at a time.



LGM-20 GOOSENECK MICROPHONE

- For use with Chairman Unit DCW-8501C and Delegate Unit DCW-8502D.
- LGM-20 Gooseneck Mic 450 mm (17.75"). Easy to connect.



SGM-40 SHOTGUN MICROPHONE

- For use with Chairman Unit DCW-8501C and Delegate Unit DCW-8502D.
- SGM-40 Shotgun Mic 225 mm (8.80"). Easy to connect.



EU-85 EXTENSION UNIT

EU-85 is a wall mountable extension antenna to cater to large conference halls with large number of units. If the distance between receiver and any unit is large then use of this extension unit will help in increasing the operating range.

To be purchased as separate unit.

DCW-8504VP DIGITAL VIDEO PROCESSOR



- Four number of HDMI inputs and four outputs to connect Pelco-D, VISCA protocol cameras.
- Supports up-to eight cameras.
- PC connectivity through software for easy installations.
- Zoom in and Zoom out facility.
- LCD display to show the setting and protocol.
- Keypad for camera selection & direction control.
- Power Supply: 12V DC using AC Adaptor.

SPECIFICATIONS

OPERATING RANGE	: Upto 30m
FREQUENCY RESPONSE	: 50-15,000Hz
POWER SUPPLY	: Chairman & Delegate Unit : 3.7V/1450mAh Li-ion Battery, Host Unit : DC: 12V Adaptor
DIMENSIONS	: Host Unit : W485 × H85 × D355 mm, Chairman Unit: W170 × H58 × D120 mm, Delegate Unit: W170 × H58 × D120 mm, Gooseneck Microphone Length: 450 mm (17.75"), Shotgun Microphone Length: 225 mm (8.80"), Extension Unit: W80 × H140 × D30 mm Digital Video Processor: W420 × H44 × D210 mm
WEIGHT	: Host Unit: 8.00kg, Chairman Unit: 700g, Delegate Unit: 700g, Gooseneck Microphone: 90g, Shotgun Microphone: 190g, Digital Video Processor: 1.96kg



Conference Systems

CM-7000 Series

50 WATTS ■ AC Operation



Ahuja Conference System CM-7000 is a versatile and easy to install system, which provides variety of features that are useful for a wide variety of Conference applications in Boardrooms, Hotels, Large Conference Halls, Convention Centres etc. Consists of a Central Amplifier which can support upto 60 Delegate Units including a Chairman Unit.

Highly sensitive 457 mm (18") long gooseneck microphone for comfortable sharing by two delegates. Chairman/Delegate Units have sleek and attractive plastic housing for superior appearance. The system can be operated in various modes: FREE, LIMIT (1-9), FIFO (1-9), VIP, PTT, APPLY and Chairman Only mode.

Voting facility available. Voting is initiated through the Chairman unit. System expansion for connecting upto 90 conference units is possible through an Extension Unit. Supplied with software for conference operation through PC / Laptop.

CMA-7400 CENTRAL AMPLIFIER



- Automatic Mic Off feature which activates after 60 seconds and can be enabled or disabled from the Central Amplifier.
- Proceedings can be recorded in the Central Amplifier through a USB pen drive.
- Central Amplifier has a 50W amplifier which can be used for connecting additional speakers through speaker output port.
- Central Amplifier has the facility of feeding four independent groups of Delegate Units as required in large conference setups
- Headphone output provided in Central Amplifier for monitoring purposes, through a 3.5 mm connector.
- RJ45 connecting ports available for using CAT-5E/6 shielded cable connections.



CMC-7100 CHAIRMAN UNIT CMD-7200 DELEGATE UNIT

- Highly sensitive and unidirectional 457 mm (18") long gooseneck condenser microphone.
- The microphone is fitted with a diffused ring LED housing.
- Conference units have LCD display which shows ON/OFF status, Voting options and Voting results.
- Delegate Unit has a TALK switch. When put ON, the LED bar in the knob of TALK switch lights up.
- Delegate unit has three voting option buttons.
- Chairman unit has an additional switch for the PRIORITY function.
- Chairman unit has five buttons for various functions in a voting application.
- RJ45 connecting ports available for using CAT-5E/6 shielded cable connections.



EU-70 EXTENSION UNIT



- Permits easy expansion by allowing connection of upto 90 conference units.
- Compact table top unit with facility of rigid mounting through fixing clamps.
- RJ45 connecting ports available for using CAT-5E/6 shielded cable connections.
- RED Led indicator for power and system operation.
- AC mains operation.

SPECIFICATIONS	CMA-7400
FREQUENCY RESPONSE	100-15,000Hz
S/N RATIO	> 96dB
AUDIO OUTPUT	+18dB Balanced
POWER REQUIREMENT	AC: 220-240V, 50/60Hz
DIMENSIONS	W485 × H105 × D330 mm
WEIGHT	4.70 kg
ACCESSORIES	F/XLR to 6.5 mm Mono Jack Cable, 15m RJ45 CAT 5E Shielded Black Cable, Audio Visual RJ45 CAT-5E Patch Cable, Software Dongle, Licence, Key Dongle, USB to RJ45 convertor.

SPECIFICATIONS	CMC-7100	CMD-7200	SPECIFICATIONS	EU-70
MICROPHONE SENSITIVITY	7mV/Pa	7mV/Pa	POWER REQUIREMENT	AC: 220-240V, 50/60Hz
FREQUENCY RESPONSE	100-15,000Hz	100-15,000Hz	POWER INDICATOR	RED LED
IMPEDANCE	1000Ω	1000Ω	CONNECTION	RJ45 PORT
CONNECTION	RJ45 Port	RJ45 Port	DIMENSIONS	W253 × H63 × D226 MM
MICROPHONE TYPE	Unidirectional Condenser	Unidirectional Condenser	WEIGHT	2.00kg
DIMENSIONS	W145 × H55 × D175mm	W145 X H55 X D175mm		
WEIGHT	550g	550g		
ACCESSORIES	Foam Windshield, 2m RJ45 CAT-5E Shielded Black Cable, Gooseneck Mic			



Conference Systems

CM-5000 Series

50 WATTS ■ AC & 24V DC Operation

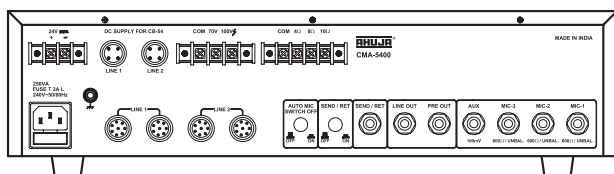

CMA-5400 CENTRAL MIXER AMPLIFIER



The new Ahuja Conference System CM-5000 facilitates smooth conduct of meetings by providing required level of intelligible sound reinforcement. The system is designed to handle a wide variety of conference applications in Boardrooms, Large Conference Halls as well as open conferencing in Convention Centres.

- Highly sensitive 470 mm (18.5") long gooseneck microphone for comfortable sharing by two delegates.
- Bright and uniform band LED indicator.
- Chairman/Delegate Units have attractive and well contoured plastic top for superior appearance.
- Rugged and compact die cast metal base for better stability of Chairman/Delegate Units.
- Adjustable headphone output available from each Chairman/Delegate Unit.
- Automatic Mic Off feature in Delegate units which is selectable through a switch in the Central Mixer Amplifier.
- Chairman Unit has Priority Switch.
- Central Mixer Amplifier has a digital recorder for recording the proceedings. Also it can playback the pre-recorded messages.
- Switchable send/return facility in Central Mixer Amplifier.
- Three Mic inputs and one Aux input in Central Mixer Amplifier.
- 50W Mixer Amplifier for adequate sound reinforcement.
- Headphone output provided in Central Mixer Amplifier for monitoring purposes.
- AC Mains & 24V DC operation.
- Central Mixer Amplifier is 482.6 mm (19") rack mountable.
- Central Mixer Amplifier has the facility of feeding two independent groups of Delegate Units if required in large conference setups.
- Conference System can be installed in a bus bar arrangement by using Junction Boxes CB-45.

CMD-5200 DELEGATE UNIT



CMC-5100 CHAIRMAN UNIT



Each unit is provided with a 470 mm (18.5") long gooseneck condenser microphone which is highly sensitive and unidirectional. The microphone is provided with a diffused LED housing to provide positive visual identification of the unit in operation. The built-in speaker in each unit provides clear and crisp sound reinforcement. The output level of the speaker can be adjusted through a recessed volume control in the unit. Each unit

has a headphone output, TALK switch and a TALK LED. The MIC LEVEL LED in the delegate unit flickers to indicate microphone input signal level.

Apart from delegate unit functions, the chairman unit has a TALK switch with LED. It also has a PRIORITY switch with LED. When PRIORITY switch is pressed, a chime tone is generated to seek attention and mute the active delegate microphones.

SPECIFICATIONS	CMA-5400
LINE OUTPUT 1	17.5V DC/3A Max.; -34dBV (20mV)
LINE OUTPUT 2	17.5V DC/3A Max.; -34dBV (20mV)
POWER OUTPUT	50W RMS at 2% THD, 90W Max.
INPUTS	3 × Mic 0.65mV/4.7kΩ 1 × Aux 100mV/470kΩ
FREQUENCY RESPONSE	60-14,000Hz (± 3dB)
SIGNAL TO NOISE RATIO	> 60dB
TONE CONTROLS	Bass: -10dB at 100Hz Treble: -10dB at 10kHz
PREAMP OUTPUT	200mV/600Ω
LINE OUTPUT	1V/1kΩ
SEND OUTPUT	200mV/600Ω
RETURN INPUT	200mV/10kΩ
SPEAKER OUTPUT	4Ω, 8Ω, 16Ω, 70V & 100V
POWER REQUIREMENT	AC: 220-240V, 50/60Hz DC: 24V (2 × 12V Car Battery)
POWER CONSUMPTION	250VA
PROTECTIONS	AC Fuse 1 × 3A, DC Fuse 3 × 10A
DIMENSIONS	W483 × H110 × D325 mm
WEIGHT	10.50kg
ACCESSORIES	1 × Connection Cable CC-46 1 × Extension Cable CC-47 1 × Fuse 3A, 2 × Fuse 10A

SPECIFICATIONS	CMC-5100	CMD-5200
MICROPHONE	7.5mV/Pa	7.5mV/Pa
CURRENT CONSUMPTION	< 50mA Max.	< 50mA Max.
MIC AUTO SWITCH-OFF TIME	—	75 seconds approx.
INPUT	Line	Line
OUTPUT	Line, Headphone	Line, Headphone
SPEAKER	Max Input 300mW	Max Input 300mW
CONTROLS	Priority Switch, Talk Switch, Speaker Volume Control, Headphone Volume Control	Talk Switch, Speaker Volume Control, Headphone Volume Control
DIMENSIONS	W118 × H70 × D160 mm	W118 × H70 × D160 mm
WEIGHT	1.05 kg (w/o cable)	1.05 kg (w/o cable)
ACCESSORIES	Foam Windshield, 2.5m Interconnecting Cable	Foam Windshield, 2.5m Interconnecting Cable

SYSTEM CONFIGURATION

CENTRAL MIXER AMPLIFIER	CMA-5400	1 Unit
CHAIRMAN UNIT	CMC-5100	1 Unit
DELEGATE UNIT	CMD-5200	N Units (N ≤ 50)



TYPICAL APPLICATIONS

Boardrooms

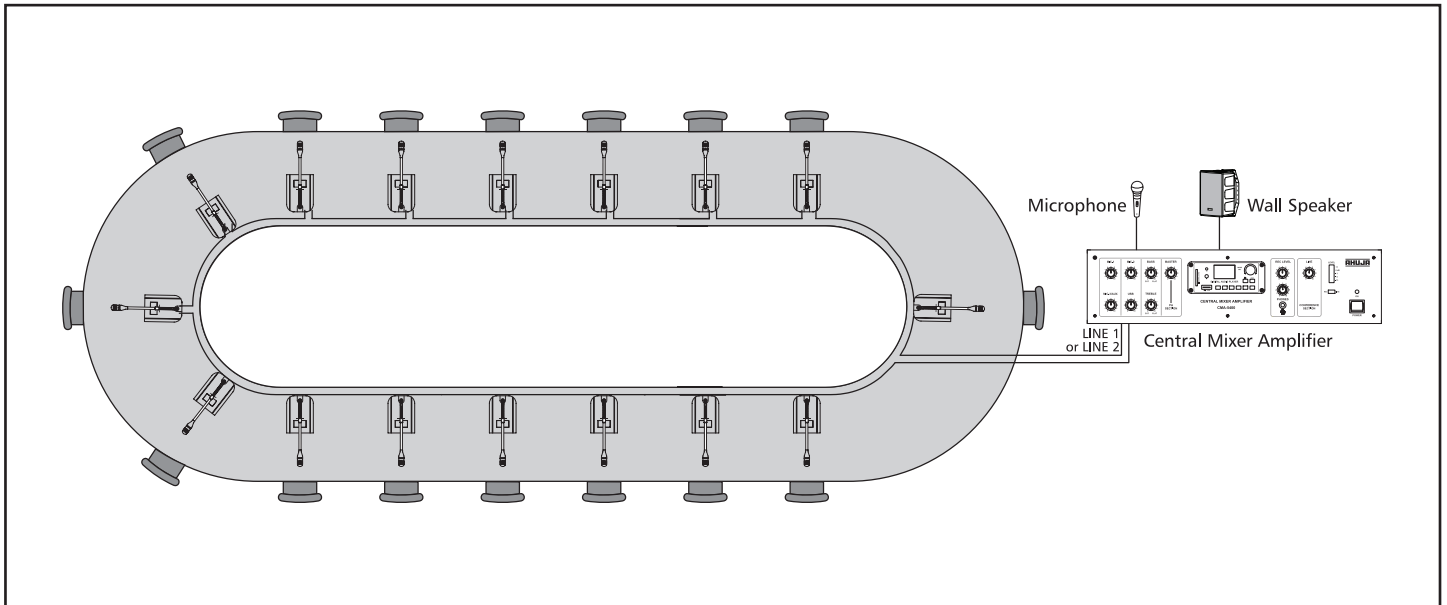

Convention Centres

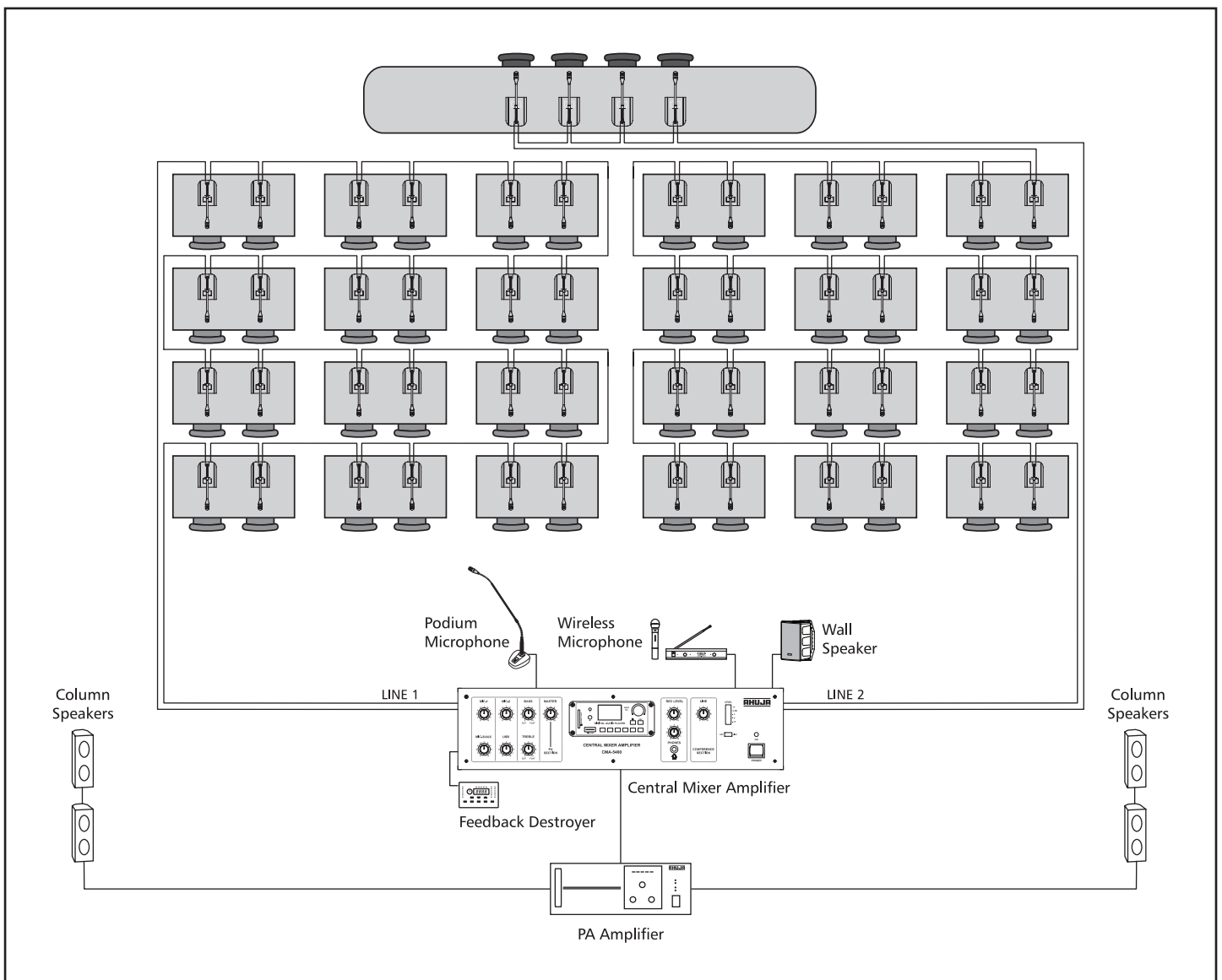



Hallmark of Reliability!

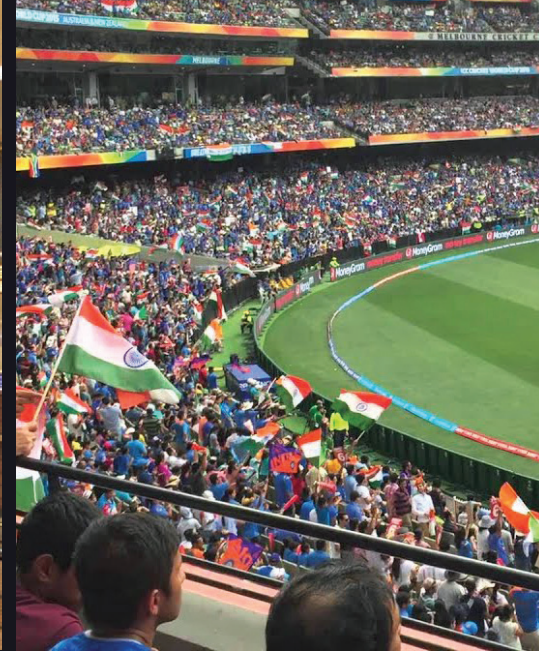

Amplifiers

World renowned, time-tested, rugged and reliable amplifiers.

Sterling quality without compromise !

Passed down from generation to generation... users & installers alike testify to the reliability of AHUJA amplifiers !

Applications

Airports | Conventions | DJs | Stadiums | Electioneering | Fairs & Exhibitions
Defence Installations | Bus Terminals | Announcements & Music | Mobile PA
Schools & Colleges | Coaching Centers | Places of Worship

Quad Channel Class D Power Amplifiers

XDA-3004

4 × 1200 WATTS ■ AC Operation

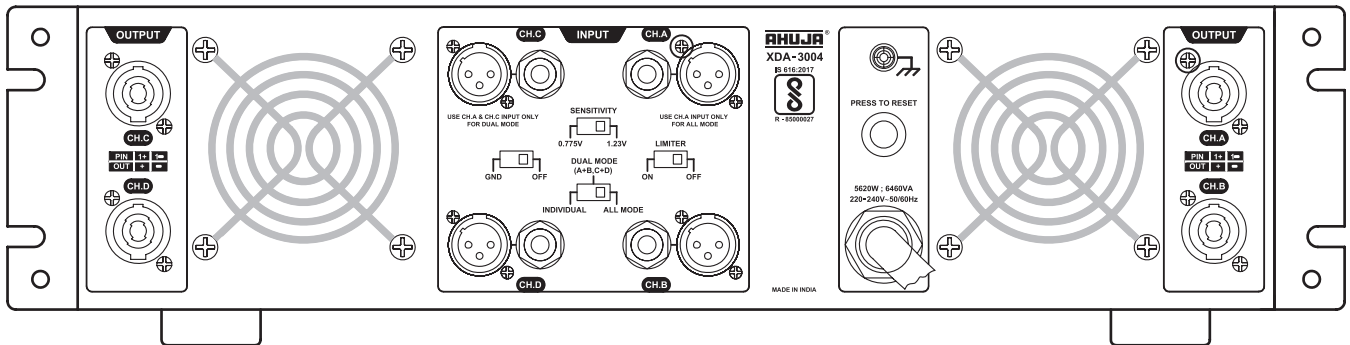
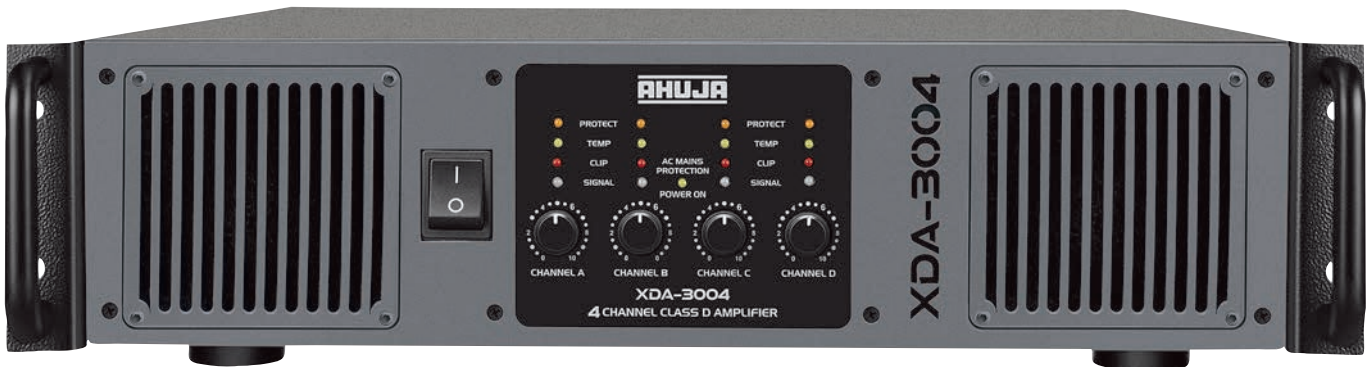

- Four Channel Class D Power Amplifier.
- 1200 Watts rated output from each channel .
- Three selectable modes of operation ie., INDIVIDUAL, DUAL and ALL.
- Built-in Limiter circuit with ON/OFF switch.
- Toroidal Transformer power supply.
- Two selectable input sensitivities.
- Built-in Amplifier Protection system: DC offset, HF, Short circuit, Thermal, Overload, Overvoltage & Clip Monitoring.
- Rack mountable in 2.5U Size.
- BIS approved.

SPECIFICATIONS	XDA-3004
CONTINUOUS RATED POWER	
STEREO/MONO	8Ω : 700W + 700W + 700W + 700W RMS, 4Ω : 1200W + 1200W + 1200W + 1200W RMS
THD + N	< 0.1%
FREQUENCY RESPONSE (-1dB)	20-20,000Hz
POWER BANDWIDTH (0.5% THD)	20-20,000Hz
INPUT SENSITIVITY	0dBu (775mV) & 4dBu (1.23V) (Selectable)
INPUT IMPEDANCE	10k Unbalanced, 20k Balanced
SIGNAL TO NOISE RATIO	> 100dB
CHANNEL SEPARATION	> 65dB at 1kHz
DAMPING FACTOR (8Ω)	>1000
SLEW RATE	20V/μS
PROTECTIONS	Temperature, DC, RFI, Short Circuit, Overload, Overvoltage, Built-in Limiter (ON/OFF) AC: Circuit Protector 20A; ± DC: Fuse 2 × 12A (T 12A L) for each channel
INPUT CONNECTORS	4 × XLR, Stereo Phone Jack 6.3mm
OUTPUT CONNECTORS	Speakon 4-Way for each channel
COOLING	4 × Variable Speed DC Fan with Temperature Sensing
FRONT PANEL CONTROLS	4 × 41 Step Level Attenuators
INDICATORS	Power ON/AC Mains Protection, Signal, Clip, Temperature, Protect (Ch. A, B, C & D)
POWER CONSUMPTION (RATED)	5620W; 6460VA @ 220-240V ~ 50/60Hz
DIMENSIONS	W482 × H126 × D540mm
WEIGHT	28.50kg

XDA-7002

2400+2400 WATTS ■ AC Operation

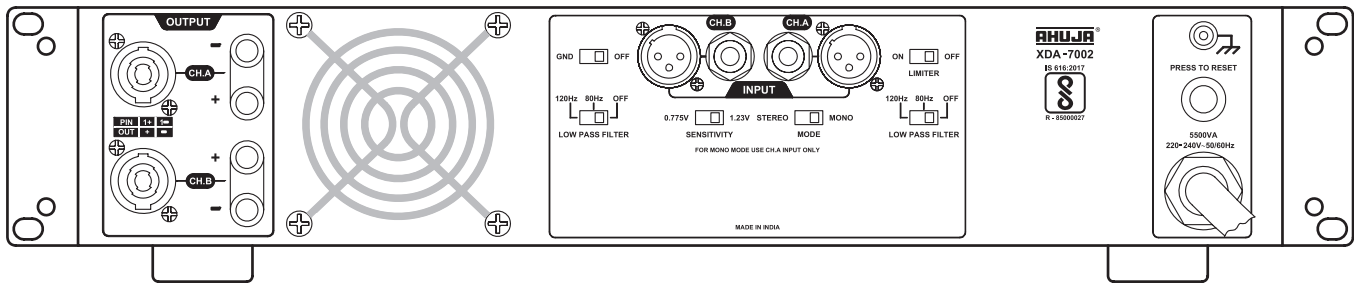

- Dual Channel Class D Power Amplifier.
- 2400 + 2400 Watts rated output.
- 80Hz/120Hz Low Pass Filter.
- Built-in Limiter circuit with ON/OFF switch.
- Toroidal Transformer power supply.
- Two selectable input sensitivities.
- Built-in Amplifier Protection system: DC offset, HF, Short circuit, Thermal, Overload, Overvoltage & Clip Monitoring.
- Compact 2U Size.
- BIS approved.

SPECIFICATIONS	XDA-7002
CONTINUOUS RATED POWER	
STEREO/MONO	8Ω : 1350W + 1350W RMS, 4Ω : 2400W + 2400W RMS
THD + N	< 0.1%
FREQUENCY RESPONSE (-1dB)	20-20,000Hz
LOW PASS FILTER	80/120Hz @ 24dB per octave
POWER BANDWIDTH (0.5% THD)	20-20,000Hz
INPUT SENSITIVITY	0dBu (775mV) & 4dBu (1.23V) (Selectable)
INPUT IMPEDANCE	10k Unbalanced, 20k Balanced
SIGNAL TO NOISE RATIO	> 100dB
CHANNEL SEPARATION	> 65dB at 1kHz
DAMPING FACTOR (8Ω)	>1000
SLEW RATE	20V/μS
PROTECTIONS	Temperature, DC, RFI, Short Circuit, Overload, Overvoltage, Built-in Limiter (ON/OFF) AC: Circuit Protector 16A; ± DC: Fuse 2× 16A (T 16A L) for each channel
INPUT CONNECTORS	2×XLR, Stereo Phone Jack 6.3mm
OUTPUT CONNECTORS	Speakon 4-Way and heavy duty Binding Post for each channel
COOLING	2 × Variable Speed DC Fan with Temperature Sensing
FRONT PANEL CONTROLS	2×41 Step Level Attenuators
INDICATORS	Power ON/AC Mains Protection, Signal, Clip, Temperature, Protect (Ch. A & B)
POWER CONSUMPTION (RATED)	5500VA @ 220-240V ~ 50/60Hz
DIMENSIONS	W482 × H104 × D438mm
WEIGHT	22.10kg



Dual Channel Class D Power Amplifiers

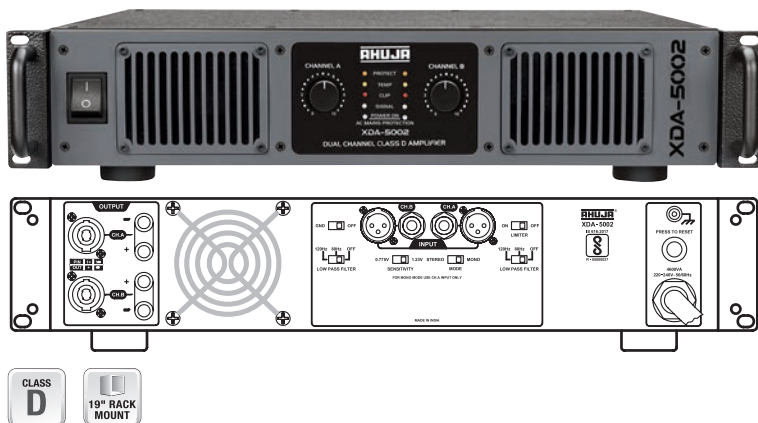

XDA-5002

1800+1800 WATTS ■ AC Operation

- Dual Channel Class D Power Amplifier.
- 1800 + 1800 Watts rated output.
- 80Hz/120Hz Low Pass Filter.
- Built-in Limiter circuit with ON/OFF switch.
- Toroidal Transformer power supply.
- Two selectable input sensitivities.
- Built-in Amplifier Protection system: DC offset, HF, Short circuit, Thermal, Overload, Overvoltage & Clip Monitoring.
- Compact 2U Size.
- BIS approved.

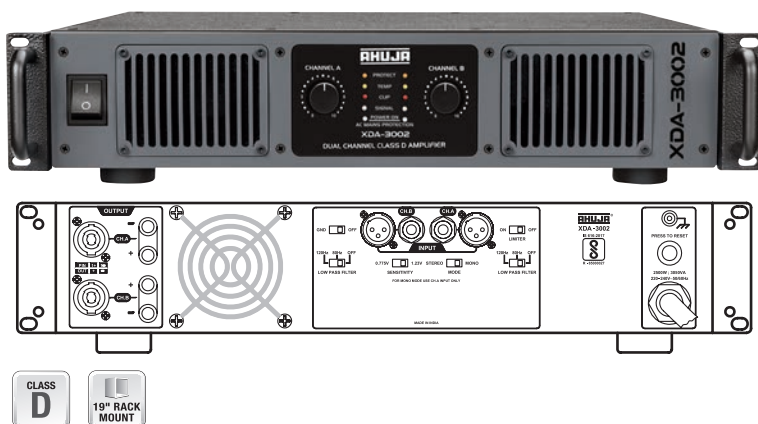

XDA-3002

1200+1200 WATTS ■ AC Operation

- Dual Channel Class D Power Amplifier.
- 1200 + 1200 Watts rated output.
- 80Hz/120Hz Low Pass Filter.
- Built-in Limiter circuit with ON/OFF switch.
- Toroidal Transformer power supply.
- Two selectable input sensitivities.
- Built-in Amplifier Protection system: DC offset, HF, Short circuit, Thermal, Overload, Overvoltage & Clip Monitoring.
- Compact 2U Size.
- BIS approved.

SPECIFICATIONS	XDA-5002	XDA-3002
CONTINUOUS RATED POWER		
STEREO/MONO	8Ω : 1100W + 1100W RMS, 4Ω : 1800W + 1800W RMS	8Ω : 700W + 700W RMS, 4Ω : 1200W + 1200W RMS
THD + N	< 0.1%	< 0.1%
FREQUENCY RESPONSE (-1dB)	20-20,000Hz	20-20,000Hz
LOW PASS FILTER	80/120Hz @ 24dB per octave	80/120Hz @ 24dB per octave
POWER BANDWIDTH (0.5% THD)	20-20,000Hz	20-20,000Hz
INPUT SENSITIVITY	0dBu (775mV) & 4dBu (1.23V) (Selectable)	0dBu (775mV) & 4dBu (1.23V) (Selectable)
INPUT IMPEDANCE	10k Unbalanced, 20k Balanced	10k Unbalanced, 20k Balanced
SIGNAL TO NOISE RATIO	> 100dB	> 100dB
CHANNEL SEPARATION	> 65dB at 1kHz	> 65dB at 1kHz
DAMPING FACTOR (8Ω)	>1000	>1000
SLEW RATE	20V/μS	20V/μS
PROTECTIONS	Temperature, DC, RFI, Short Circuit, Overload, Overvoltage, Built-in Limiter (ON/OFF) AC: Circuit Protector 15A; ± DC: Fuse 2 × 15A (T 15A L) for each channel	Temperature, DC, RFI, Short Circuit, Overload, Overvoltage, Built-in Limiter (ON/OFF) AC: Circuit Protector 10A; ± DC: Fuse 2 × 10A (T 10A L) for each channel
INPUT CONNECTORS	2 × XLR, Stereo Phone Jack 6.3mm	2 × XLR, Stereo Phone Jack 6.3mm
OUTPUT CONNECTORS	Speakon 4-Way and heavy duty Binding Post for each channel	Speakon 4-Way and heavy duty Binding Post for each channel
COOLING	2 × Variable Speed DC Fan with Temperature Sensing	2 × Variable Speed DC Fan with Temperature Sensing
FRONT PANEL CONTROLS	2 × 41 Step Level Attenuators	2 × 41 Step Level Attenuators
INDICATORS	Power ON/AC Mains Protection, Signal, Clip, Temperature, Protect (Ch. A & B)	Power ON/AC Mains Protection, Signal, Clip, Temperature, Protect (Ch. A & B)
POWER CONSUMPTION (RATED)	4600VA @ 220-240V ~ 50/60Hz	2500W; 3050VA @ 220-240V ~ 50/60Hz
DIMENSIONS	W482 × H104 × D438mm	W482 × H104 × D438mm
WEIGHT	21.50kg	18.80kg

LXA-7600

3800+3800 WATTS ■ AC Operation

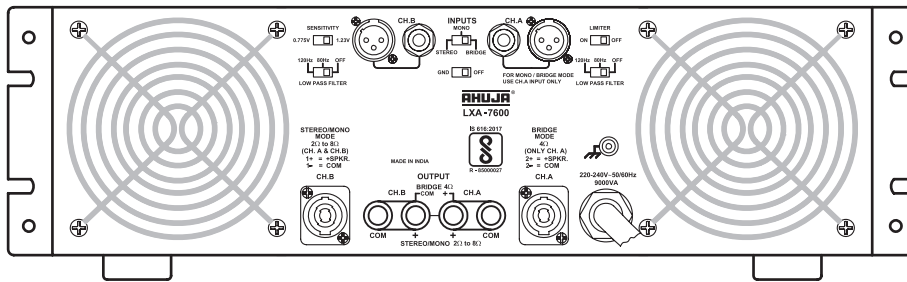

- Dual channel direct coupled power amplifier.
- 7600 Watts rated output.
- Rugged and most reliable. A new benchmark for professionals requiring a sonically superior high power amplifier.
- 80Hz/120Hz LPF.
- Built-in circuit for HF protection.
- Limiter ON/OFF switch.
- Two selectable input sensitivities.
- Class H operation for optimum efficiency.
- BIS approved.

SPECIFICATIONS

LXA-7600

CONTINUOUS RATED POWER	
STEREO/MONO	8Ω : 1600W + 1600W RMS, 4Ω : 2600W + 2600W RMS 2Ω : 3800W + 3800W RMS
BRIDGED OUTPUT	8Ω : 5200W RMS, 4Ω : 7600W RMS
THD + N	< 1.0%
FREQUENCY RESPONSE (-1dB)	20-20,000Hz
LOW PASS FILTER	80/120Hz @ 24dB per octave
POWER BANDWIDTH (0.5% THD)	20-20,000Hz
INPUT SENSITIVITY	0dBu (775mV) & 4dBu (1.23V) (Selectable)
INPUT IMPEDANCE	10k Unbalanced, 20k Balanced
SIGNAL TO NOISE RATIO	> 95dB
CHANNEL SEPARATION	> 65dB at 1kHz
DAMPING FACTOR (8Ω)	> 500
SLEW RATE	35V/μS
PROTECTIONS	Temperature, DC, RFI, Short Circuit, Overload, Built-in Limiter (ON/OFF) AC: Magnetic Circuit Protector 20A; ± DC: Fuse 1 X 30A (T 30A L) for each Channel, Fuse 2 X 3 A (T 3A L)
INPUT CONNECTORS	2 X XLR, Stereo Phone Jack 6.3mm
OUTPUT CONNECTORS	Speakon 4-Way and heavy duty Binding Post for each channel
COOLING	2 X Fixed Speed DC Fan and 2 X Variable Speed DC Fan with Temperature Sensing
FRONT PANEL CONTROLS	2 X 41 Step Level Attenuators
INDICATORS	Power ON, Signal, Clip, Temperature, Protect (Ch. A & B)
POWER CONSUMPTION (RATED)	9000VA @ 220-240V ~ 50/60Hz
DIMENSIONS	W482 X H153 X D605mm
WEIGHT	39.50kg



Dual Channel Power Amplifiers

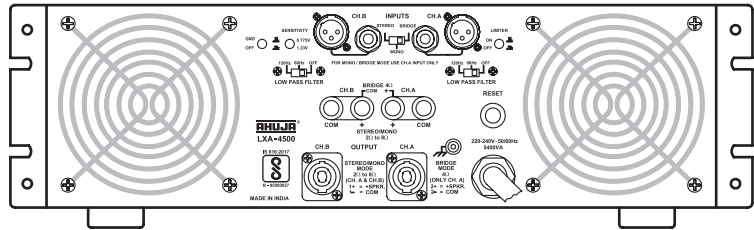
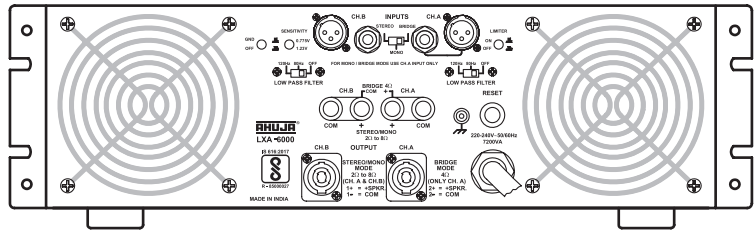

LXA-6000

3000+3000 WATTS ■ AC Operation

- Dual channel direct coupled power amplifier.
- 6000 Watts rated output.
- Rugged and most reliable. A new benchmark for professionals requiring a sonically superior high power amplifier.
- 80Hz/120Hz LPF.
- Built-in circuit for HF protection.
- Limiter ON/OFF switch.
- Two selectable input sensitivities.
- Class H operation for optimum efficiency.
- BIS approved.

LXA-4500

2250+2250 WATTS ■ AC Operation

- Dual channel direct coupled power amplifier.
- 4500 Watts rated output.
- Rugged and most reliable. A new benchmark for professionals requiring a sonically superior high power amplifier.
- 80Hz/120Hz LPF.
- Built-in circuit for HF protection.
- Limiter ON/OFF switch.
- Two selectable input sensitivities.
- Class H operation for optimum efficiency.
- BIS approved.

SPECIFICATIONS	LXA-6000	LXA-4500
CONTINUOUS RATED POWER		
STEREO/MONO	8Ω : 1300W + 1300W RMS, 4Ω : 2000W + 2000W RMS 2Ω : 3000W + 3000W RMS	8Ω : 1000W + 1000W RMS, 4Ω : 1550W + 1550W RMS 2Ω : 2250W + 2250W RMS
BRIDGED OUTPUT	8Ω : 4000W RMS, 4Ω : 6000W RMS	8Ω : 3100W RMS, 4Ω : 4500W RMS
THD + N	< 1.0%	< 1.0%
FREQUENCY RESPONSE (-1dB)	20-20,000Hz	20-20,000Hz
LOW PASS FILTER	80/120Hz @ 24dB per octave	80/120Hz @ 24dB per octave
POWER BANDWIDTH (0.5% THD)	20-20,000Hz	20-20,000Hz
INPUT SENSITIVITY	0dBu (775mV) & 4dBu (1.23V) (Selectable)	0dBu (775mV) & 4dBu (1.23V) (Selectable)
INPUT IMPEDANCE	10k Unbalanced, 20k Balanced	10k Unbalanced, 20k Balanced
SIGNAL TO NOISE RATIO	> 95dB	> 95dB
CHANNEL SEPARATION	> 65dB at 1kHz	> 65dB at 1kHz
DAMPING FACTOR (8Ω)	> 500	> 500
SLEW RATE	35V/μS	35V/μS
PROTECTIONS	Temperature, DC, RFI, Short Circuit, Overload, Built-in Limiter (ON/OFF) AC: Circuit Protector 25A; ± DC: Fuse 2 X 30A (T 30A L) for each channel, Fuse 2 X 3 A (T 3A L)	Temperature, DC, RFI, Short Circuit, Overload, Built-in Limiter (ON/OFF) AC: Circuit Protector 20A; ± DC: Fuse 2 X 25A (T 25A L) for each channel, Fuse 2 X 3 A (T 3A L)
INPUT CONNECTORS	2 X XLR, Stereo Phone Jack 6.3mm	2 X XLR, Stereo Phone Jack 6.3mm
OUTPUT CONNECTORS	Speakon 4-Way and heavy duty Binding Post for each channel	Speakon 4-Way and heavy duty Binding Post for each channel
COOLING	Variable Speed DC Fan with Temperature Sensing	Variable Speed DC Fan with Temperature Sensing
FRONT PANEL CONTROLS	2 X 41 Step Level Attenuators	2 X 41 Step Level Attenuators
INDICATORS	Power ON, Signal, Clip, Temperature, Protect (Ch. A & B)	Power ON, Signal, Clip, Temperature, Protect (Ch. A & B)
POWER CONSUMPTION (RATED)	7200VA @ 220-240V ~ 50/60Hz	5400VA @ 220-240V ~ 50/60Hz
DIMENSIONS	W482 X H153 X D605mm	W482 X H153 X D580mm
WEIGHT	39.00kg	36.50kg

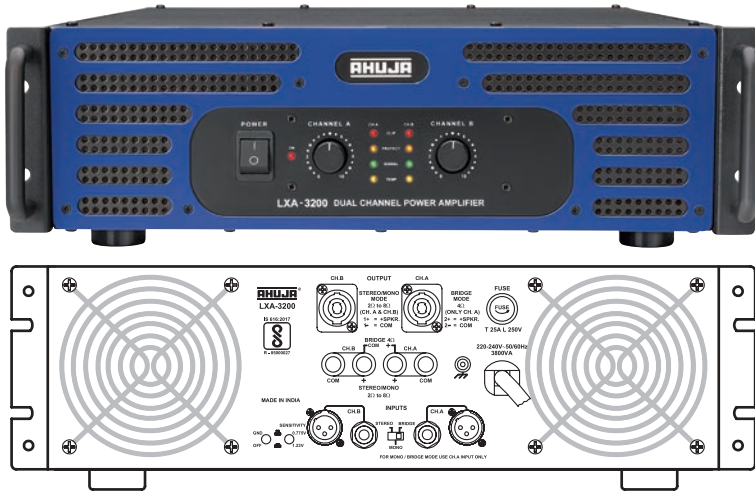

LXA-3200

1600+1600 WATTS ■ AC Operation

- Dual channel direct coupled power amplifier.
- 3200 Watts rated output.
- Rugged, reliable and designed to work continuously under stringent conditions
- High fidelity sound.
- Ideal for high end music programmes.
- Two selectable input sensitivities.
- Class H operation for optimum efficiency.
- BIS approved.

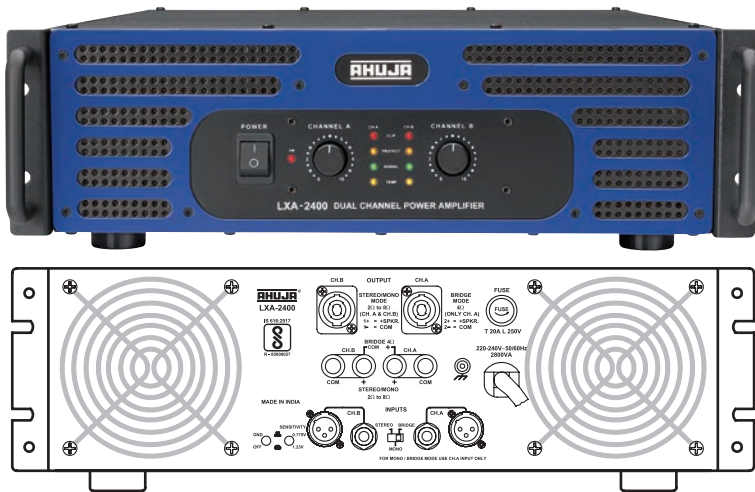

LXA-2400

1200+1200 WATTS ■ AC Operation

- Dual channel direct coupled power amplifier.
- 2400 Watts rated output.
- Rugged and most reliable. A new benchmark for professionals requiring a sonically superior high power amplifier.
- Two selectable input sensitivities.
- Class H operation for optimum efficiency.
- BIS approved.

SPECIFICATIONS

	LXA-3200	LXA-2400
CONTINUOUS RATED POWER		
STEREO/MONO	8Ω : 700W + 700W RMS, 4Ω : 1100W + 1100W RMS 2Ω : 1600W + 1600W RMS	8Ω : 600W + 600W RMS, 4Ω : 850W + 850W RMS 2Ω : 1200W + 1200W RMS
BRIDGED OUTPUT	8Ω : 2200W RMS, 4Ω : 3200W RMS	8Ω : 1700W RMS, 4Ω : 2400W RMS
THD + N	< 1.0%	< 1.0%
FREQUENCY RESPONSE (-1dB)	20-20,000Hz	20-20,000Hz
POWER BANDWIDTH (0.5% THD)	20-20,000Hz	20-20,000Hz
INPUT SENSITIVITY	0dBu (775mV) & 4dBu (1.23V) (Selectable)	0dBu (775mV) & 4dBu (1.23V) (Selectable)
INPUT IMPEDANCE	10k Unbalanced, 20k Balanced	10k Unbalanced, 20k Balanced
SIGNAL TO NOISE RATIO	> 95dB	> 95dB
CHANNEL SEPARATION	> 65dB at 1kHz	> 65dB at 1kHz
DAMPING FACTOR (8Ω)	> 500	> 500
SLEW RATE	35V/μS	35V/μS
PROTECTIONS	Temperature, DC, RFI, Short Circuit, Overload, Built-in Limiter AC: Fuse 25Amp. (T 25A L); ± DC: Fuse 2 X 25A (T 25A L) for each channel, Fuse 2 X 3 A (T 3A L)	Temperature, DC, RFI, Short Circuit, Overload, Built-in Limiter AC: Fuse 20A (T 20A L); ± DC: Fuse 2 X 20A (T 20A L) for each channel, Fuse 2 X 3A (T 3A L)
INPUT CONNECTORS	2 X XLR, Stereo Phone Jack 6.3mm	2 X XLR, Stereo Phone Jack 6.3mm
OUTPUT CONNECTORS	Speakon 4-Way and heavy duty Binding Post for each channel	Speakon 4-Way and heavy duty of Binding Post for each channel
COOLING	Variable Speed DC Fan with Temperature Sensing	Variable Speed DC Fan with Temperature Sensing
FRONT PANEL CONTROLS	2 X 41 Step Level Attenuators	2 X 41 step level Attenuators
INDICATORS	Power ON, Signal, Clip, Temperature, Protect (Ch. A & B)	Power ON, Signal, Clip, Temperature, Protect (Ch. A & B)
POWER CONSUMPTION (RATED)	3800VA @ 220-240V ~ 50/60Hz	2800VA @ 220-240V ~ 50/60Hz
DIMENSIONS	W482 X H153 X D550mm	W482 X H153 X D550mm
WEIGHT	33.00kg	28.70kg



Dual Channel Power Amplifiers

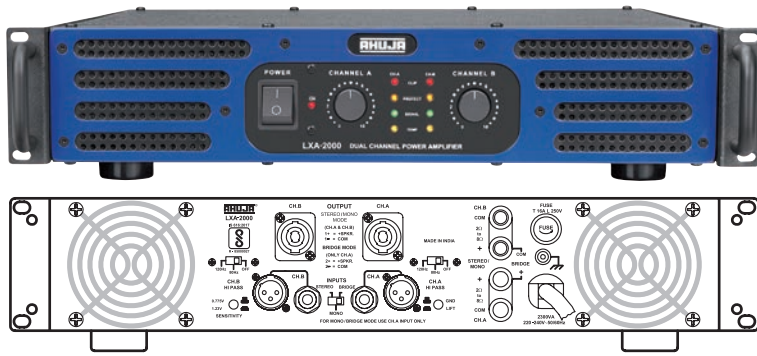

LXA-2000

1000+1000 WATTS ■ AC Operation

- Dual channel direct coupled power amplifier.
- 2000 Watts rated output.
- Rugged and most reliable. A new benchmark for professionals requiring a sonically superior high power amplifier.
- Selectable HPF (120Hz/80Hz/OFF)
- Two selectable input sensitivities.
- Class H operation for optimum efficiency.
- BIS approved.

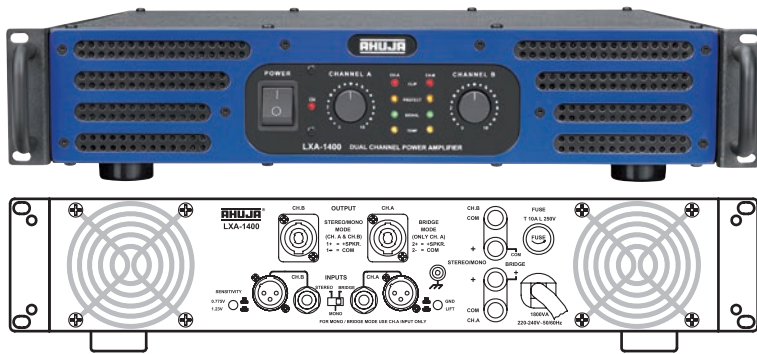

LXA-1400

675+675 WATTS ■ AC Operation

- Dual channel direct coupled power amplifier.
- 1350 Watts rated output.
- Rugged, reliable and designed to work continuously under stringent conditions
- High fidelity sound.
- Two selectable input sensitivities.
- Ideal for high end music programmes.

SPECIFICATIONS

	LXA-2000	LXA-1400
CONTINUOUS RATED POWER		
STEREO/MONO	8Ω : 400W + 400W RMS, 4Ω : 700W + 700W RMS 2Ω : 1000W + 1000W RMS	8Ω : 250W + 250W RMS, 4Ω : 475W + 475W RMS 2Ω : 675W + 675W RMS
BRIDGED OUTPUT	8Ω : 1400W RMS, 4Ω : 2000W RMS	8Ω : 950W RMS, 4Ω : 1350W RMS
THD + N	< 1.0%	< 1.0%
FREQUENCY RESPONSE (-1dB)	20-20,000Hz	20-20,000Hz
POWER BANDWIDTH (0.5% THD)	20-20,000Hz	20-20,000Hz
HIGH PASS FILTER	80/120Hz @ 12dB per octave	—
INPUT SENSITIVITY	0dBu (775mV) & 4dBu (1.23V) (Selectable)	0dBu (775mV) & 4dBu (1.23V) (Selectable)
INPUT IMPEDANCE	10k Unbalanced, 20k Balanced	10k Unbalanced, 20k Balanced
SIGNAL TO NOISE RATIO	> 95dB	> 95dB
CHANNEL SEPARATION	> 65dB at 1kHz	> 65dB at 1kHz
DAMPING FACTOR (8Ω)	> 500	> 500
SLEW RATE	35V/μS	35V/μS
PROTECTIONS	Temperature, DC, RFI, Short Circuit, Overload, Built-in Limiter AC: Fuse 16A (T 16A L); ± DC: Fuse 2 × 16A (T 16A L) for each channel, ± DC: Fuse 2 × 2A (T 2A L) (for Fan Supply)	Temperature, DC, RFI, Short Circuit, Overload, Built-in Limiter, AC: Fuse 10A (T 10A L); ± DC: Fuse 2 × 10A (T 10A L) for each channel, ± DC: Fuse 2 × 2A (T 2A L) (for Fan Supply)
INPUT CONNECTORS	2 × XLR, Stereo Phone Jack 6.3mm	2 × XLR, Stereo Phone Jack 6.3mm
OUTPUT CONNECTORS	Speakon 4-Way and Heavy duty Binding Post for each channel	Speakon 4-Way and Heavy duty Binding Post for each channel
COOLING	Variable Speed DC Fan with Temperature Sensing	Variable Speed DC Fan with Temperature Sensing
FRONT PANEL CONTROLS	2 × 41 Step Level Attenuators	2 × 21 Step Level Attenuators
INDICATORS	Power ON, Signal, Clip, Temperature, Protect (Ch. A & B)	Power ON, Signal, Clip, Temperature, Protect (Ch. A & B)
POWER CONSUMPTION (RATED)	2300VA @ 220-240V ~ 50/60Hz	1800VA @ 220-240V ~ 50/60Hz
DIMENSIONS	W482 × H113 × D530mm	W482 × H113 × D460mm
WEIGHT	21.90kg	14.70kg

DXA-3502

1750+1750 WATTS ■ AC Operation

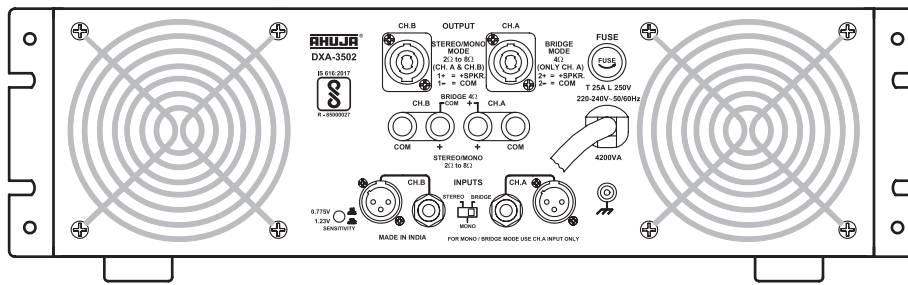

DXA-3502 is a rugged and most reliable dual channel power amplifier. It sets a new benchmark for professionals requiring a sonically superior, high power amplifier. It has been designed to operate under stringent working conditions such as wide voltage fluctuations due to DG Set/AC mains and high ambient temperatures. Adequate safeguards have been built-in to counter adverse working conditions. Ease of operation, combined with service accessibility has been optimized in the design. Class H operation for optimum efficiency. BIS approved.

SPECIFICATIONS	DXA-3502
CONTINUOUS RATED POWER	
STEREO/MONO	8Ω : 700W + 700W RMS, 4Ω : 1200W + 1200W RMS 2Ω : 1750W + 1750W RMS
BRIDGED OUTPUT	8Ω : 2400W RMS, 4Ω : 3500W RMS
SINGLE CHANNEL DRIVEN OUTPUT	8Ω : 750W RMS, 4Ω : 1350W RMS, 2Ω : 1900W RMS
THD + N	0.5%
FREQUENCY RESPONSE (-1dB)	20-20,000Hz
POWER BANDWIDTH (0.5% THD)	20-20,000Hz
INPUT SENSITIVITY	0dBu (775mV) & 4dBu (1.23V) (Selectable)
INPUT IMPEDANCE	10k Unbalanced , 20k Balanced
SIGNAL TO NOISE RATIO	> 95dB
CHANNEL SEPARATION	> 65dB at 1kHz
DAMPING FACTOR (8Ω)	> 500
SLEW RATE	35V/μs
PROTECTIONS	Temperature, DC, RFI, Short Circuit, Overload, AC over voltage, Built-in limiter AC: Fuse 25A (T 25A L), ± DC: Fuse 2×25A (T 25A L) each channel & Fuses 2×3A (T 3A L)
INPUT CONNECTORS	2×XLR, Stereo Phone Jack 6.3mm
OUTPUT CONNECTORS	Speakon 4-Way and Heavy Duty Binding Post for each channel
COOLING	Variable Speed DC Fan with Temperature Sensing
FRONT PANEL CONTROLS	2×41 Step Level Attenuators
INDICATORS	ON, Signal, Clip, Temperature, Protect (Ch. A & B)
POWER CONSUMPTION	4200VA @ 220-240V ~ 50/60Hz
DIMENSIONS	W482 × H153 × D580mm
WEIGHT	37.50kg



Two Zone PA Power Amplifiers

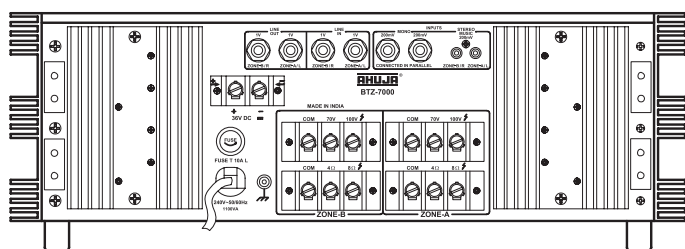
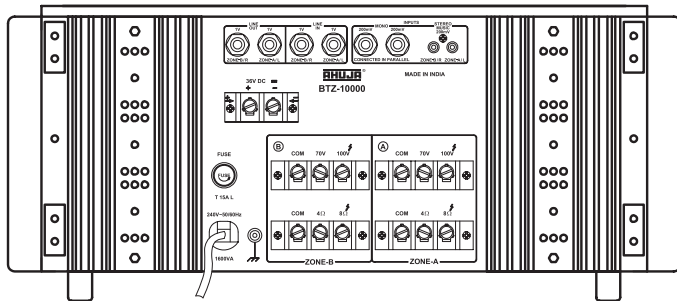

BTZ-10000

1000 WATTS ■ AC & 36V DC Operation

- Stereo Music input for DJ programmes.
- Facilitates connection and operation of two groups of speakers simultaneously on 'Mono' mode. Ideal for Places of Worship.
- Line Input & Output on each zone for connecting to a PA Mixer and a Booster Amplifier respectively.
- Box Speaker/Driver Unit selector switch for each zone. Bass boost defeated at Driver Unit position for safer operation of driver units.
- Resettable circuit breaker for protection against overload and short circuit.
- Zone On/Off facility. Output levels of each Zone can be set independently to desired levels and the zones can be switched On/Off without disturbing the volume settings.
- Instant transfer to DC power (Car Battery) if AC power fails.
- Bar Graph Signal Display.

BTZ-7000

700 WATTS ■ AC & 36V DC Operation

- Stereo Music Operation for DJ programmes.
- Facilitates connection and operation of two separate groups of speakers simultaneously on 'Mono' mode. Ideal for places of worship.
- Box Speaker/Driver Unit selector switch for each zone. Bass boost defeated at Driver Unit position for safer operation of driver units.
- Resettable circuit breaker for protection against overload and short circuit.
- Zone On/Off facility. Output levels of each Zone can be set independently to desired levels and the zones can be switched On/Off without disturbing the volume settings.
- Instant transfer to DC power (Car Battery) if AC power fails.
- Bar Graph Signal Display.

SPECIFICATIONS	BTZ-10000	BTZ-7000
POWER OUTPUT	750W + 750W Max., 500W + 500W RMS at 10% THD 450W + 450W RMS at 5% THD, 415W + 415W RMS at 2% THD	500W + 500W Max., 350W + 350W RMS at 10% THD 300W + 300W RMS at 5% THD, 280W + 280W RMS at 2% THD
OUTPUT REGULATION	≤ 2 dB, no load to full load at 1kHz	≤ 2 dB, no load to full load at 1kHz
INPUT CHANNELS	Mono 2 × 200mV/100kΩ	Mono 2 × 200mV/100kΩ
FREQUENCY RESPONSE	Stereo L/R 200mV/100kΩ, Line L/R 1V/50kΩ 50-15,000Hz ±3dB	Stereo L/R 200mV/100kΩ, Line L/R 1V/50kΩ 50-15,000Hz ±3dB
SIGNAL TO NOISE RATIO	60dB	60dB
TONE CONTROLS	Bass: ±10dB at 100Hz, Treble: ±10dB at 10kHz	Bass: ±10dB at 100Hz, Treble: ±10dB at 10kHz
OUTPUTS	Line 1V/1kΩ	Line L/R 1V/1kΩ
SPEAKER OUTPUTS	4Ω, 8Ω, 70V & 100V for each zone	4Ω, 8Ω, 70V & 100V for each zone
POWER SUPPLY	AC: 220-240V 50/60Hz DC: 36V (3 × 12V Car Battery)	AC: 220-240V 50/60Hz DC: 36V (3 × 12V Car Battery)
POWER CONSUMPTION	AC: 1600VA DC: 16A	AC: 1100VA DC: 13A
DIMENSIONS	W510 × H220 × D440 mm	W510 × H185 × D470 mm
WEIGHT	40.00kg	39.00kg

Two Zone PA Mixer Amplifiers

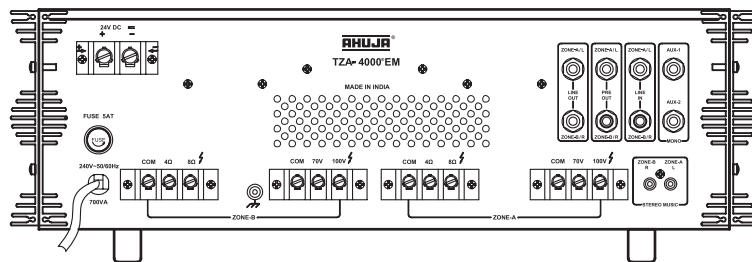
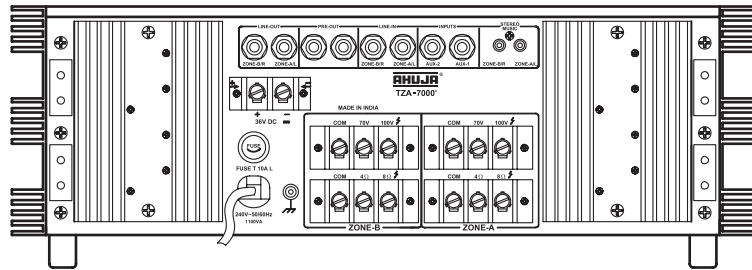

Ahuja models TZA-7000® and TZA-4000®EM are rugged, reliable, cost-effective 700 Watts & 400 Watts Two Zone PA Mixer Amplifiers. These are ideal for multi-speaker installations where a user needs to separately set power levels for two separate areas such as indoors & outdoors.

TZA-7000®

700 WATTS ■ AC & 36V DC Operation

- 6 Mic & 2 Aux Inputs.
- Stereo Music Operation for DJ programmes.
- Facilitates connection and operation of two separate groups of speakers simultaneously on 'Mono' mode. Ideal for Places of Worship.
- Line Input & Output on each zone for connecting to a PA Mixer and a Booster Amplifier respectively. Preamplifier output for recording.
- Box Speaker/Driver Unit selector switch for each zone. Bass boost defeated at Driver Unit position for safer operation of driver units. Zone On/Off facility.
- Resettable circuit breaker for protection against overload and short circuit.
- Instant transfer to DC power (Car Battery) if AC power fails.
- Bar Graph Signal Display.

TZA-4000®EM

400 WATTS ■ AC & 24V DC Operation

- 6 Mic & 2 Aux Inputs.
- Stereo Music Operation for DJ programmes.
- Facilitates connection and operation of two separate groups of speakers simultaneously on Mono mode. Ideal for Places of Worship.
- Line Input & Output on each zone for connecting to a PA Mixer and a Booster Amplifier respectively. Preamplifier output for recording.
- Box Speaker/Driver Unit selector switch for each zone. Bass boost defeated at Driver Unit position for safer operation of driver units. Zone On/Off facility.
- Resettable circuit breaker for protection against overload and short circuit.
- Instant transfer to DC power (Car Battery) if AC power fails.
- Bar Graph Signal Display.

SPECIFICATIONS	TZA-7000®	TZA-4000®EM
POWER OUTPUT	500W + 500W Max., 350W + 350W RMS at 10% THD 300W + 300W RMS at 5% THD, 280W + 280W RMS at 2% THD	300W + 300W Max., 200W + 200W RMS at 10% THD 180W + 180W RMS at 5% THD, 165W + 165W RMS at 2% THD
OUTPUT REGULATION	≤ 2 dB, no load to full load at 1kHz	≤ 2 dB, no load to full load at 1kHz
INPUT CHANNELS	Mono 6 × Mic 0.6mV/4.7kΩ, 2 × Aux 100mV/470kΩ Stereo L/R 200mV/100kΩ, Line L/R 1V/50kΩ	Mono 6 × Mic 0.6mV/4.7kΩ, 2 × Aux 100mV/470kΩ Stereo L/R 200mV/100kΩ, Line L/R 1V/50kΩ
FREQUENCY RESPONSE	50-15,000Hz ± 3dB	50-15,000Hz ± 3dB
SIGNAL TO NOISE RATIO	60dB	60dB
TONE CONTROLS	Bass: ± 10dB at 100Hz, Treble: ± 10dB at 10kHz	Bass: ± 10dB at 100Hz, Treble: ± 10dB at 10kHz
OUTPUTS	Preamp 200mV/600Ω, Line 1V/1kΩ	Preamp 200mV/600Ω, Line 1V/1kΩ
SPEAKER OUTPUTS	4Ω, 8Ω, 70V & 100V for each zone	4Ω, 8Ω, 70V & 100V for each zone
POWER SUPPLY	AC: 220-240V 50/60Hz DC: 36V (3 × 12V Car Battery)	AC: 220-240V 50/60Hz DC: 24V (2 × 12V Car Battery)
POWER CONSUMPTION	AC: 1100VA DC: 13A	AC: 700VA DC: 9A
DIMENSIONS	W510 × H185 × D470 mm	W510 × H172 × D385 mm
WEIGHT	39.80kg	24.20kg



Two Zone PA Mixer Amplifiers

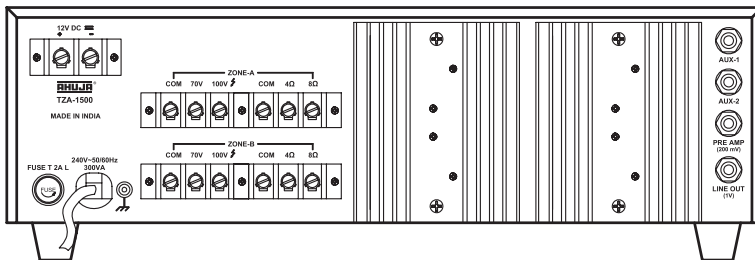
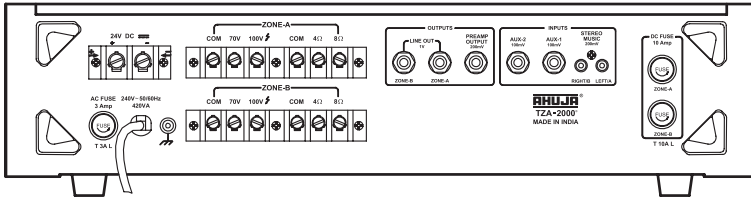

TZA-2000®

200 WATTS ■ AC & 24V DC Operation

- 6 Mic & 2 Aux Inputs.
- Features 'Stereo' music operation, connecting of two separate groups of speakers, line inputs & outputs, preamplifier outputs, zone On/Off facility, DC fuses at rear panel, AC/DC operation.
- Ideal for medium sized installations such as in places of worship where two separate groups of speakers are needed to be connected.
- User has a choice to connect both the zones to 100V (LMT) type speakers, or 100V speakers to one zone and low impedance type speakers to the other zone. Both the zones can also be connected to low impedance type speakers.
- Instant transfer to DC power (Car Battery) if AC power fails.

TZA-1500

160 WATTS ■ AC & 12V DC Operation

- 6 Mic & 2 Aux Inputs.
- Preamplifier output for connecting to a Booster Amplifier and for recording the programme.
- Bass & Treble Controls.
- TZA-1500 permits connecting 100V (LMT) type speakers to one Zone and low impedance type speakers to other Zone without causing overloading and over heating.
- Instant transfer to DC power (Car Battery) if AC power fails.
- Zone On/Off facility. Output levels of each Zone can be set independently to desired levels and the zones can be switched On/Off without disturbing the volume settings.

Ahuja models TZA-2000® and TZA-1500 are rugged, reliable, cost-effective 200 Watts & 160 Watts Two Zone PA Mixer Amplifiers. Ideal for use in small and medium sized installations such as in Schools, Banquet Halls, Places of Worship etc., where separate sets of speakers for indoors & outdoors are needed.

SPECIFICATIONS	TZA-2000®	TZA-1500
POWER OUTPUT	130W + 130W Max., 100W + 100W RMS at 10% THD 90W + 90W RMS at 5% THD, 80W + 80W RMS at 2% THD	100W + 100W Max., 80W + 80W RMS at 10% THD 70W + 70W RMS at 5% THD, 60W + 60W RMS at 2% THD
OUTPUT REGULATION	≤ 2 dB, no load to full load at 1kHz	≤ 2 dB, no load to full load at 1kHz
INPUT CHANNELS	Mono 6 × Mic 0.6mV/4.7kΩ, 2 × Aux 100mV/470kΩ	6 × Mic 0.6mV/4.7kΩ, 2 × Aux 100mV/470 kΩ
FREQUENCY RESPONSE	50-15,000Hz ±3dB	65-15,000Hz ±3dB
SIGNAL TO NOISE RATIO	60dB	60dB
TONE CONTROLS	Bass: ±10dB at 100Hz, Treble: ±10dB at 10kHz	Bass: -10dB at 100Hz, Treble: -10dB at 10kHz
OUTPUTS	Preamp 200mV/600Ω, Line 1V/1kΩ	Preamp 200mV/600Ω
SPEAKER OUTPUTS	4Ω, 8Ω, 70V & 100V for each zone	4Ω, 8Ω, 70V & 100V for each zone
POWER SUPPLY	AC: 220-240V 50/60Hz DC: 24V (2 × 12V Car Battery)	AC: 220-240V 50/60Hz DC: 12V (12V Car Battery)
POWER CONSUMPTION	AC: 420VA DC: 6.5A	AC: 300VA DC: 6A
DIMENSIONS	W500 × H140 × D340 mm	W460 × H155 × D310 mm
WEIGHT	17.40kg	14.20kg

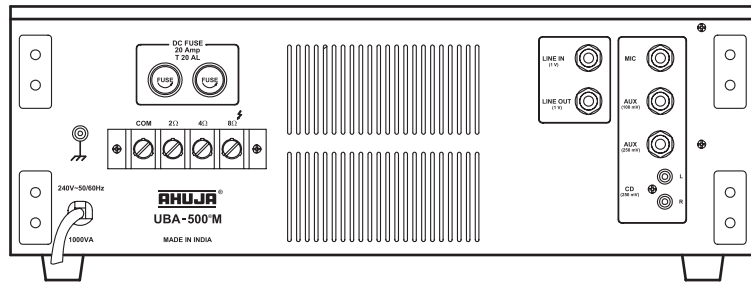
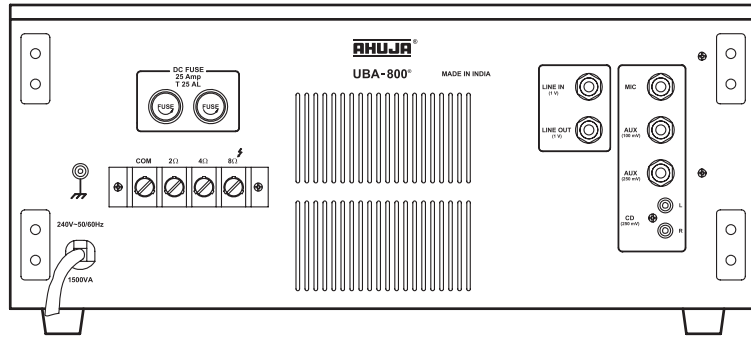

UBA-800®

800 WATTS ■ AC Operation

- Designed for use in a wide variety of PA applications and DJ performances.
- UBA-800® is a 800 Watts amplifier which can be connected to various input sources like a Microphone, PA Mixer, DJ Mixer, CD Player, Cassette Player, Keyboard etc.
- The amplifier includes a built-in 5 Band Graphic Equalizer with tone ON/OFF switch which enables precise and accurate tonal setting of the programme.
- Line Input and Line Output have been provided to enable interconnections with other power amplifiers.

UBA-500®M

500 WATTS ■ AC Operation

- Designed for use in a wide variety of PA applications and DJ performances.
- UBA-500®M is a 500 Watts amplifier which can be connected to various input sources like a Microphone, PA Mixer, DJ Mixer, CD Player, Cassette Player, Keyboard etc.
- The amplifier includes a built-in 5 Band Graphic Equalizer with tone ON/OFF switch which enables precise and accurate tonal setting of the programme.
- Features are similar to UBA-800®.

SPECIFICATIONS	UBA-800®	UBA-500®M
Power Output	1150W RMS Max., 800W RMS at 10%THD 770W RMS at 5% THD 725W RMS at 2% THD	650W RMS Max., 500W RMS at 10%THD 475W RMS at 5% THD 450W RMS at 2% THD
OUTPUT REGULATION	≤ 2dB, no load to full load at 1kHz	≤ 2dB, no load to full load at 1kHz
INPUT CHANNELS	1 × Mic 1mV / 4.7kΩ, 1 × Aux 100mV/470kΩ, 1 × Aux 250mV/20kΩ 1 × CD 250mV / 20kΩ, 1 × Line 1V / 10kΩ	1 × Mic 1mV / 4.7kΩ, 1 × Aux 100mV/470kΩ, 1 × Aux 250mV/20kΩ 1 × CD 250mV / 20kΩ, 1 × Line 1V / 10kΩ
FREQUENCY RESPONSE	50Hz – 18,000Hz ± 3dB	50Hz – 18,000Hz ± 3dB
SIGNAL TO NOISE RATIO	60dB	60dB
TONE CONTROLS	Bass (100Hz) ± 8dB, Lo-Mid (315Hz) ± 8dB Mid (1kHz) ± 8dB, Hi-Mid (3.1kHz) ± 8dB, Treble (10kHz) ± 8dB	Bass (100Hz) ± 8dB, Lo-Mid (315Hz) ± 8dB Mid (1kHz) ± 8dB, Hi-Mid (3.1kHz) ± 8dB, Treble (10kHz) ± 8dB
LINE OUTPUT	1V/1kΩ	1V/1kΩ
SPEAKER OUTPUT	2Ω, 4Ω & 8Ω	2Ω, 4Ω & 8Ω
POWER SUPPLY	AC: 220-240V 50/60Hz	AC: 220-240V 50/60Hz
PROTECTIONS	2 × 25A fuse in ± DC supply, 8A circuit breaker in AC mains Protected against high AC mains voltage, overload & temperature	2 × 20A fuse in ± DC supply, 5A circuit breaker in AC mains Protected against high AC mains voltage, overload & temperature
POWER CONSUMPTION	1500 VA	1000 VA
DIMENSIONS	W482 × H186 × D512 mm	W482 × H166 × D435 mm
WEIGHT	33.00kg	22.50kg



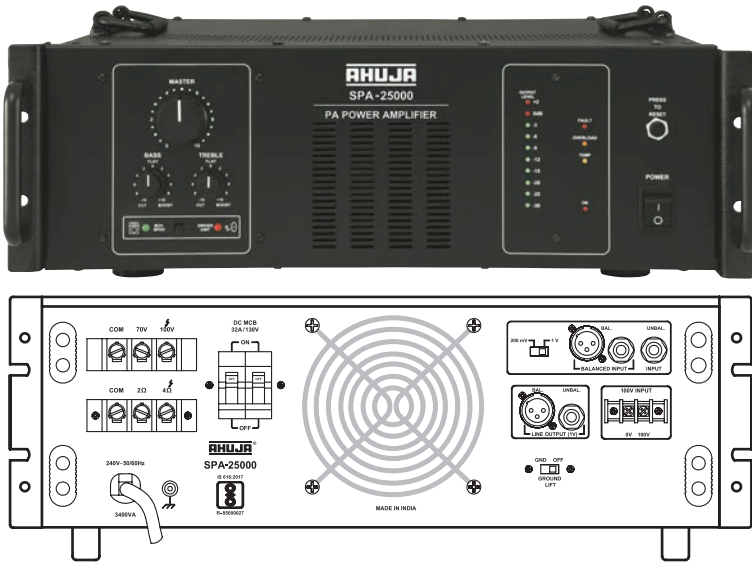

SPA-25000

2500 WATTS ■ AC Operation

- Designed for use in big installations where large number of speakers are required.
- Line Input 200mV/1V switchable for connecting a mixer or another amplifier. 100V input for connecting to 100V output of another amplifier.
- Built-in protection against overvoltage in AC mains supply which is specially useful while operating on a DG set. Built-in circuit for protection against overload, short circuit and temperature.
- Box Speaker/Driver Unit selector switch. Bass boost defeated at Driver Unit position for safer operation of driver units. 100V/70V, 4Ω and 2Ω power outputs.
- BIS approved.

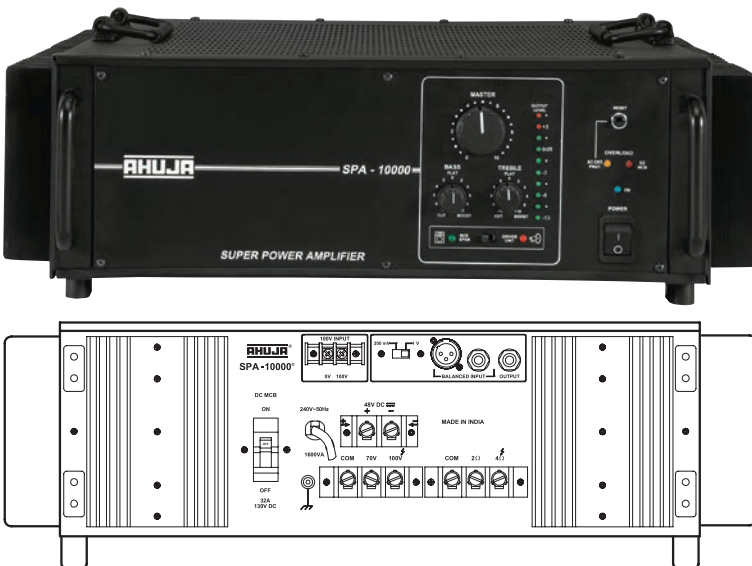

SPA-10000®

1000 WATTS ■ AC & 48V DC Operation

- Line Input 200mV/1V switchable for connecting a PA mixer or another amplifier.
- 100V input for connecting another amplifier output.
- Resettable circuit breaker for protection against overload and short circuit.
- Instant transfer to DC power if AC power fails.
- Box Speaker/Driver Unit selector switch. Bass boost defeated at Driver Unit position for safer operation of driver units.
- Ideal for large installations where a high power output is required. A combination of a SSA-10000 and one SPA-10000 can deliver 2000W power output.

SPECIFICATIONS	SPA-25000	SPA-10000®
POWER OUTPUT	3000W Max., 2500W RMS at 10% THD 2300W RMS at 5% THD, 2150W RMS at 2% THD	1350W Max., 1000W RMS at 10% THD 850W RMS at 5% THD, 800W RMS at 2% THD
OUTPUT REGULATION	≤ 2 dB, no load to full load at 1kHz	≤ 2 dB, no load to full load at 1kHz
INPUT CHANNELS	1 × Line 200mV/20kΩ balanced (10kΩ unbal.), 1 × Line 1V/20kΩ balanced (10kΩ unbal.), 1 × 100V Input/100kΩ	1 × Line 200mV/100kΩ, 1 × Line 1V/50kΩ, 1 × 100V Input/50kΩ
FREQUENCY RESPONSE	50-15,000Hz ±3dB	50-15,000Hz ±3dB
SIGNAL TO NOISE RATIO	75dB	60dB
TONE CONTROLS	Bass: ±10dB at 100Hz, Treble: ±10dB at 10kHz	Bass: ±10dB at 100Hz, Treble: ±10dB at 10kHz
SPEAKER OUTPUTS	2Ω, 4Ω, 70V & 100V	2Ω, 4Ω, 70V & 100V
POWER SUPPLY	AC: 220-240V 50/60Hz	AC: 220-240V 50/60Hz, DC: 48V (4× 12V Car Battery)
PROTECTIONS	AC: 15Amp. Circuit Protector, DC: 2 × 32A Circuit Protector Protected against high AC mains voltage,	AC: 10Amp. Circuit Protector DC: 32Amp. MCB
POWER CONSUMPTION	AC: 3400VA	AC: 1600VA DC: 12A
DIMENSIONS	W520 × H185 × D595 mm	W540 × H185 × D510 mm
WEIGHT	38.50kg	41.00kg

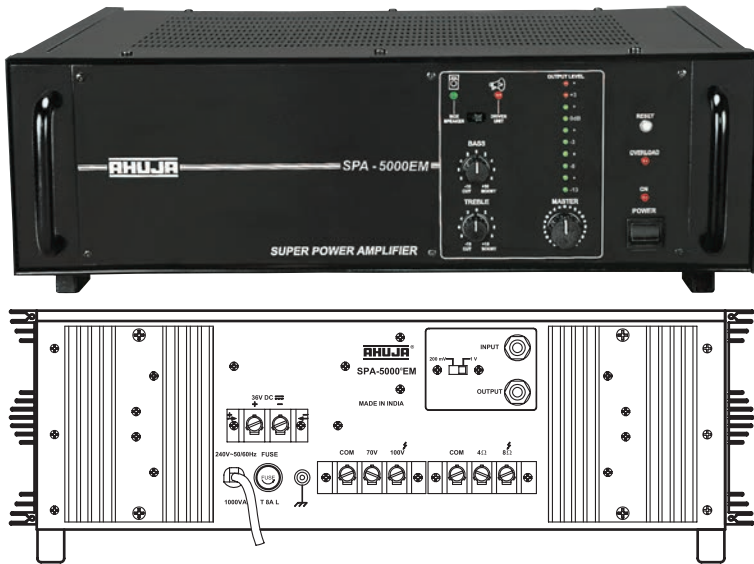

SPA-5000[®]EM

500 WATTS ■ AC & 36V DC Operation

- Line Input 200mV/1V switchable for connecting a PA mixer or another amplifier.
- Resettable circuit breaker for protection against overload and short circuit.
- Instant transfer to DC power (Car Battery) if AC power fails.
- Box Speaker/Driver Unit selector switch. Bass boost defeated at Driver Unit position for safer operation of driver units.
- Ideal for large installations where a high power output is required. A combination of a SSA-5000EM and one SPA-5000EM can deliver 1000W power output.



BR-250M

250 WATTS ■ AC & 24V DC Operation

- Line Input 200mV/1V switchable for connecting a PA mixer or another amplifier.
- Resettable circuit breaker for protection against overload and short circuit. Instant transfer to DC power (Car Battery) if AC power fails.
- Box Speaker/Driver Unit selector switch. Bass boost defeated at Driver Unit position for safer operation of driver units.
- By connecting four booster amplifiers BR-250M to one SSA-250M, the user can have a 1250W mono system.
- Instant transfer to DC power (Car Battery) if AC power fails.

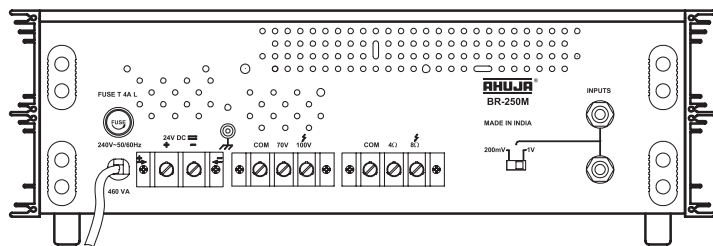

SPECIFICATIONS

	SPA-5000 [®] EM	BR-250M
POWER OUTPUT	750W Max., 500W RMS at 10% THD 450W RMS at 5% THD, 415W RMS at 2% THD	300W Max., 250W RMS at 10% THD 220W RMS at 5% THD, 200W RMS at 2% THD
OUTPUT REGULATION	≤ 2 dB, no load to full load at 1kHz	≤ 2 dB, no load to full load at 1kHz
INPUT CHANNELS	1 × Line 200mV/100kΩ, 1 × Line 1V/50kΩ	1 × Line 200mV/100kΩ, 1 × Line 1V/50kΩ
FREQUENCY RESPONSE	50-15,000Hz ±3dB	50-15,000Hz ±3dB
SIGNAL TO NOISE RATIO	60dB	60dB
TONE CONTROLS	Bass: ±10dB at 100Hz, Treble: ±10dB at 10kHz	Bass: ±10dB at 100Hz, Treble: ±10dB at 10kHz
SPEAKER OUTPUTS	4Ω, 8Ω, 70V & 100V	4Ω, 8Ω, 70V & 100V
POWER SUPPLY	AC: 220-240V 50/60Hz, DC: 36V (3×12V Car Battery)	AC: 220-240V 50/60Hz, DC: 24V (2×12V Car Battery)
POWER CONSUMPTION	AC: 1000VA DC: 8A	AC: 460VA DC: 6A
DIMENSIONS	W510 × H172 × D385 mm	W450 × H160 × D340 mm
WEIGHT	25.70kg	15.00kg



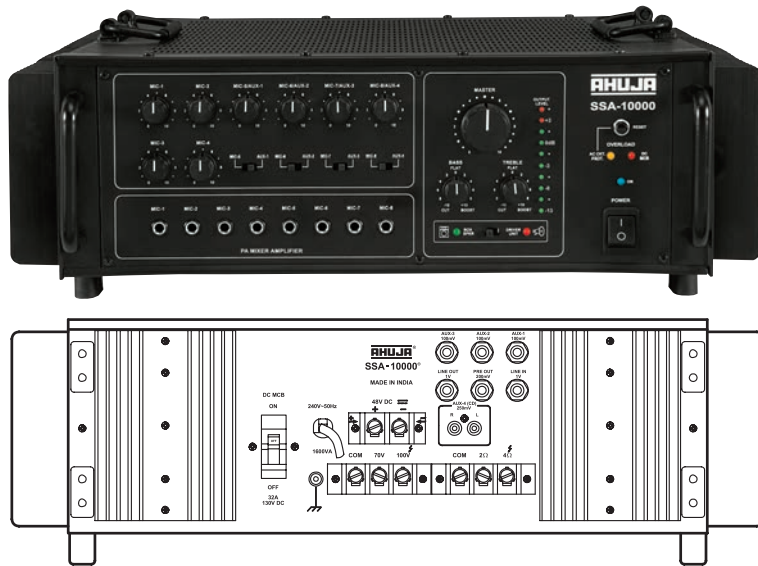

SSA-10000®

1000 WATTS ■ AC & 48V DC Operation

- 8 Mic & 4 Aux Inputs. Aux-4 input is through RCA socket specially for connecting CD/DVD player.
- Preamplifier and Line Output for connecting to a Booster Amplifier and for recording the programme.
- Line Input for connecting the output from any external PA mixer or permitting SSA-10000 to be used as a Booster Power Amplifier.
- Resettable circuit breaker & MCB at back for protection against overload and short circuit.
- Instant transfer to DC power if AC power fails.
- Box Speaker/Driver Unit selector switch. Bass boost defeated at Driver Unit position for safer operation of driver units.

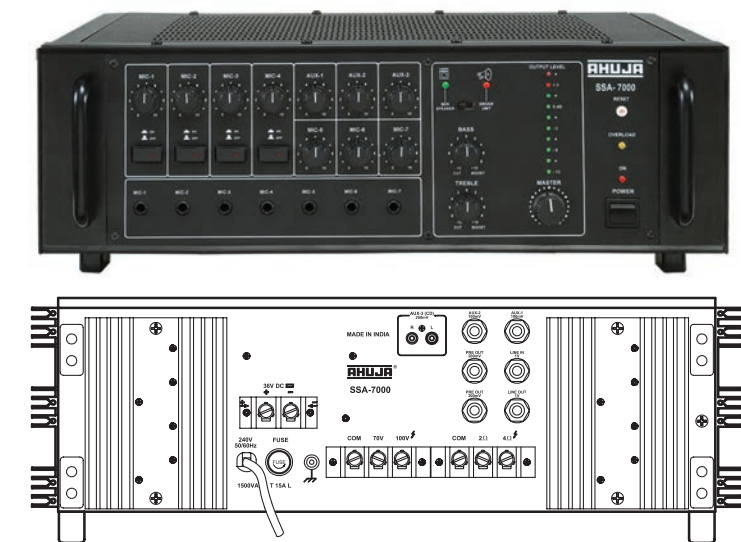

SSA-7000

700 WATTS ■ AC & 36V DC Operation

- 7 Mic & 3 Aux Inputs. Aux-3 input is through RCA socket specially for connecting CD/DVD player.
- Preamplifier and Line Output for connecting to a Booster Amplifier and for recording the programme.
- Line Input for connecting the output from any external PA mixer or permitting SSA-7000 to be used as a Booster Power Amplifier.
- Resettable circuit breaker for protection against overload and short circuit.
- Instant transfer to DC power if AC power fails.
- Box Speaker/Driver Unit selector switch. Bass boost defeated at Driver Unit position for safer operation of driver units.

SPECIFICATIONS	SSA-10000®	SSA-7000
POWER OUTPUT	1350W Max., 1000W RMS at 10% THD 850W RMS at 5% THD, 800W RMS at 2% THD	950W Max., 700W RMS at 10% THD 600W RMS at 5% THD, 570W RMS at 2% THD
OUTPUT REGULATION	≤ 2 dB, no load to full load at 1kHz	≤ 2 dB, no load to full load at 1kHz
INPUT CHANNELS	8 × Mic 0.8mV/4.7kΩ, 3 × Aux 100mV/50 kΩ 1 × Aux 250mV/50 kΩ, 1 × Line 1V/50kΩ	7 × Mic 0.8mV/4.7kΩ, 2 × Aux 100mV/50kΩ 1 × Aux 250mV/50kΩ, 1 × Line 1V/50kΩ
FREQUENCY RESPONSE	50-15,000Hz ±3dB	50-15,000Hz ±3dB
SIGNAL TO NOISE RATIO	60dB	60dB
TONE CONTROLS	Bass: ±10dB at 100Hz, Treble: ±10dB at 10kHz	Bass: ±10dB at 100Hz, Treble: ±10dB at 10kHz
OUTPUTS	Preamp 200mV/600Ω, Line 1V/1kΩ	Preamp 200mV/600Ω, Line 1V/1kΩ
SPEAKER OUTPUTS	2Ω, 4Ω, 70V & 100V	2Ω, 4Ω, 70V & 100V
POWER SUPPLY	AC: 220-240V 50/60Hz DC: 48V (4 × 12V Car Battery)	AC: 220-240V 50/60Hz DC: 36V (3 × 12V Car Battery)
POWER CONSUMPTION	AC: 1600VA DC: 12A	AC: 1100VA DC: 11A
DIMENSIONS	W540 × H185 × D510 mm	W510 × H185 × D400 mm
WEIGHT	42.00kg	38.00kg

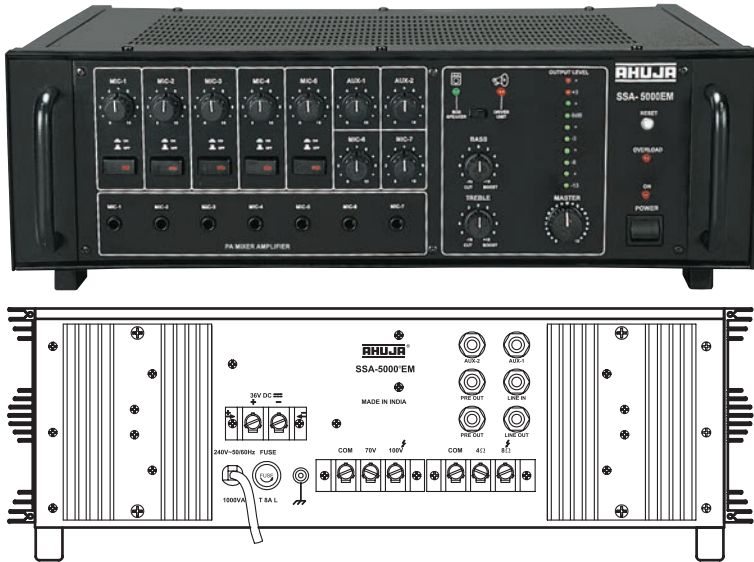

SSA-5000[®]EM

500 WATTS ■ AC & 36V DC Operation

- 7 Mic & 2 Aux Inputs.
- Preamplifier and Line Output for connecting to a Booster Amplifier and for recording the programme.
- Line Input for connecting the output from any external PA mixer or permitting SSA-5000EM to be used as a Booster Power Amplifier.
- Resettable circuit breaker for protection against overload and short circuit.
- Instant transfer to DC power (Car Battery) if AC power fails.
- Box Speaker/Driver Unit selector switch. Bass boost defeated at Driver Unit position for safer operation of driver units.

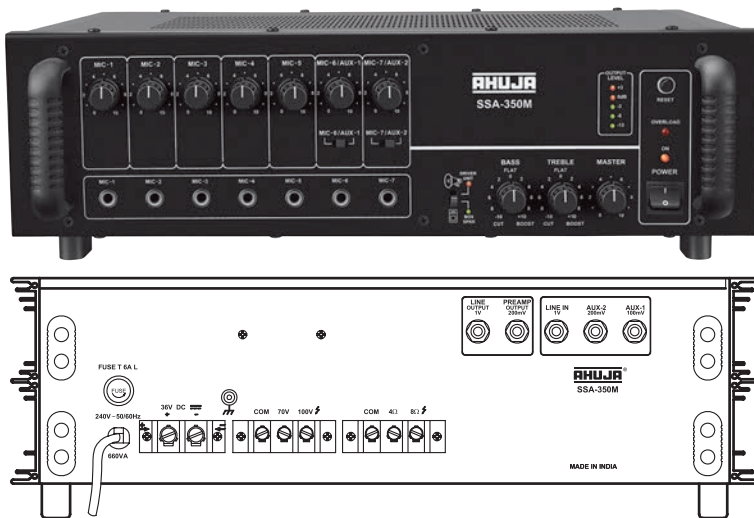

SSA-350M

350 WATTS ■ AC & 36V DC Operation

- 7 Mic & 2 Aux Inputs.
- Preamplifier and Line Output for connecting to a Booster Amplifier and for recording the programme.
- Line Input for connecting the output from any external PA mixer or permitting SSA-350M to be used as a Booster Power Amplifier.
- Resettable circuit breaker for protection against overload and short circuit. Instant transfer to DC power (Car Battery) if AC power fails.
- Box Speaker/Driver Unit selector switch. Bass boost defeated at Driver Unit position for safer operation of driver units.
- Instant transfer to DC power (Car Battery) if AC power fails.

Ahuja models SSA-5000[®]EM and SSA-350M are highly reliable PA Mixer Amplifiers. These are designed to give high power clean sound and trouble free operation under extreme climatic conditions.

SPECIFICATIONS	SSA-5000 [®] EM	SSA-350M
POWER OUTPUT	750W Max., 500W RMS at 10% THD 450W RMS at 5% THD, 415W RMS at 2% THD	450W Max., 350W RMS at 10% THD 320W RMS at 5% THD, 300W RMS at 2% THD
OUTPUT REGULATION	≤ 2 dB, no load to full load at 1kHz	≤ 2 dB, no load to full load at 1kHz
INPUT CHANNELS	7 × Mic 0.8mV/4.7kΩ, 2 × Aux 100mV/470 kΩ 1 × Line 1V/50kΩ	7 × Mic 0.8mV/4.7kΩ, 1 × Aux 100mV/470kΩ 1 × Line 1V/50kΩ
FREQUENCY RESPONSE	50-15,000Hz ±3dB	50-15,000Hz ±3dB
SIGNAL TO NOISE RATIO	60dB	60dB
TONE CONTROLS	Bass: ±10dB at 100Hz, Treble: ±10dB at 10kHz	Bass: ±10dB at 100Hz, Treble: ±10dB at 10kHz
OUTPUTS	Preamp 200mV/600Ω, Line 1V/1kΩ	Preamp 200mV/600Ω, Line 1V/1kΩ
SPEAKER OUTPUTS	4Ω, 8Ω, 70V & 100V	4Ω, 8Ω, 70V & 100V
POWER SUPPLY	AC: 220-240V 50/60Hz DC: 36V (3 × 12V Car Battery)	AC: 220-240V 50/60Hz DC: 36V (3 × 12V Car Battery)
POWER CONSUMPTION	AC: 1000VA DC: 8A	AC: 660VA DC: 6A
DIMENSIONS	W510 × H172 × D385 mm	W480 × H155 × D360 mm
WEIGHT	26.70kg	18.90kg





SSA-250[®]M

250 WATTS ■ AC & 24V DC Operation

- 6 Mic & 2 Aux Inputs.
- Preamplifier and Line Output for connecting to a Booster Amplifier and for recording the programme.
- Line Input for connecting any external mixer or permitting SSA-250[®]M to be used as a Booster Power Amplifier.
- Resettable circuit breaker for overload and short circuit protection. Instant transfer to DC power (Car Battery) if AC power fails.
- Box Speaker/Driver Unit selector switch. Bass boost defeated at Driver Unit position for safer operation of driver units.

SSA-250[®]FX

250 WATTS ■ AC & 24V DC Operation

- 6 Mic & 2 Aux Inputs.
- Built-in digital effect processor for 2 Mic Inputs.
- Preamplifier and Line Output for connecting to a Booster Amplifier and for recording the programme.
- Line Input for connecting any external mixer or permitting SSA-250[®]M to be used as a Booster Power Amplifier.
- Resettable circuit breaker for overload and short circuit protection. Instant transfer to DC power (Car Battery) if AC power fails.
- Box Speaker/Driver Unit selector switch. Bass boost defeated at Driver Unit position for safer operation of driver units.

SSA-160[®]EM

160 WATTS ■ AC & 24V DC Operation

- 5 Mic & 2 Aux Inputs.
- Preamplifier and Line Output for connecting to a Booster Amplifier and for recording the programme.
- Line Input for connecting any external mixer or permitting SSA-160[®]EM to be used as a Booster Power Amplifier.
- Resettable circuit breaker for overload and short circuit protection. Instant transfer to DC power (Car Battery) if AC power fails.
- Box Speaker/Driver Unit selector switch. Bass boost defeated at Driver Unit position for safer operation of driver units.

SPECIFICATIONS	SSA-250 [®] M	SSA-250 [®] FX	SSA-160 [®] EM
POWER OUTPUT	300W Max., 250W RMS at 10% THD 220W RMS at 5% THD, 200W RMS at 2% THD	300W Max., 250W RMS at 10% THD 220W RMS at 5% THD, 200W RMS at 2% THD	220W Max., 160W RMS at 10% THD 140W RMS at 5% THD, 120W RMS at 2% THD
OUTPUT REGULATION	≤ 2 dB, no load to full load at 1kHz	≤ 2 dB, no load to full load at 1kHz	≤ 2 dB, no load to full load at 1kHz
INPUT CHANNELS	6 × Mic 0.65mV/4.7kΩ, 2 × Aux 100mV/470 kΩ, 1 × Line 1V/50kΩ	6 × Mic 0.65mV/4.7kΩ, 2 × Aux 100mV/470 kΩ, 1 × Line 1V/50kΩ	5 × Mic 0.65mV/4.7kΩ, 2 × Aux 100mV/470 kΩ, 1 × Line 1V/50kΩ
DELAY SYSTEM	—	Digital Signal Processing	—
DELAY RANGE SETTING	—	60-300ms	—
FREQUENCY RESPONSE	50-15,000Hz ±3dB	50-15,000Hz ±3dB	50-15,000Hz ±3dB
SIGNAL TO NOISE RATIO	60dB	60dB	60dB
TONE CONTROLS	Bass: ±10dB at 100Hz, Treble: ±10dB at 10kHz	Bass: ±10dB at 100Hz, Treble: ±10dB at 10kHz	Bass: ±10dB at 100Hz, Treble: ±10dB at 10kHz
OUTPUTS	Preamp 200mV/600Ω, Line 1V/1kΩ	Preamp 200mV/600Ω, Line 1V/1kΩ	Preamp 200mV/600Ω, Line 1V/1kΩ
SPEAKER OUTPUTS	4Ω, 8Ω, 70V & 100V	4Ω, 8Ω, 70V & 100V	4Ω, 8Ω, 70V & 100V
POWER SUPPLY	AC: 220-240V 50/60Hz DC: 24V (2 × 12V Car Battery)	AC: 220-240V 50/60Hz DC: 24V (2 × 12V Car Battery)	AC: 220-240V 50/60Hz DC: 24V (2 × 12V Car Battery)
POWER CONSUMPTION	AC: 460VA DC: 6A	AC: 460VA DC: 6A	AC: 300VA DC: 4A
DIMENSIONS	W450 × H160 × D340 mm	W450 × H160 × D340 mm	W420 × H155 × D320 mm
WEIGHT	15.40kg	15.70kg	13.60kg



SSA-100®M

100 WATTS ■ AC & 24V DC Operation

- 5 Mic & 2 Aux Inputs.
- Pre-amplifier and Line Output for connecting to a Booster Amplifier and for recording the programme.
- Cut type Bass & Treble controls.
- Instant transfer to DC power (Car Battery) if AC power fails.



SSB-120®

120 WATTS ■ AC & 12V DC Operation

- 5 Mic & 2 Aux Inputs.
- Line Output for connecting to a Booster Amplifier and Pre-amplifier Output for recording the programme.
- Cut type Bass & Treble controls.
- Instant transfer to DC power (Car Battery) if AC power fails.



SSB-85FX

80 WATTS ■ AC & 12V DC Operation

- 4 Mic & 1 Aux Inputs.
- Built-in digital echo effect on Mic-4.
- Mic-3 is alternate to Aux through switch.
- Mic-1 & Mic-2 having LO-CUT facility.
- Pre-amplifier Output for connecting to a Booster Amplifier and for recording the programme.
- Cut type Bass & Treble controls.
- Instant transfer to DC power (Car Battery) if AC power fails.

SPECIFICATIONS	SSA-100®M	SSB-120®	SSB-85FX
POWER OUTPUT	130W Max., 100W RMS at 10% THD 90W RMS at 5% THD, 80W RMS at 2% THD	160W Max., 120W RMS at 10% THD 105W RMS at 5% THD, 95W RMS at 2% THD	110W Max., 80W RMS at 10% THD 75W RMS at 5% THD, 60W RMS at 2% THD
OUTPUT REGULATION	≤ 2 dB, no load to full load at 1kHz	—	≤ 2 dB, no load to full load at 1kHz
INPUT CHANNELS	5 × Mic 0.65mV/4.7kΩ, 1 × Aux 50mV/470kΩ 1 × Aux 150mV/470kΩ	5 × Mic 0.65mV/4.7kΩ, 2 × Aux 100mV/470 kΩ	4 × Mic 0.65mV/4.7kΩ, 1 × Aux 100mV/470kΩ
FREQUENCY RESPONSE	50-15,000Hz ±3dB	50-15,000Hz ±3dB	65-15,000Hz ±3dB
SIGNAL TO NOISE RATIO	60dB	60dB	60dB
TONE CONTROLS	Bass: -10dB at 100Hz, Treble: -10dB at 10kHz	Bass: -10dB at 100Hz, Treble: -10dB at 10kHz	Bass: -10dB at 100Hz, Treble: -10dB at 10kHz
OUTPUTS	Preamp 200mV/600Ω, Line 1V/1kΩ	Preamp 200mV/600Ω, Line 1V/1kΩ	Preamp 200mV/600Ω
SPEAKER OUTPUTS	4Ω, 8Ω, 16Ω, 70V & 100V	4Ω, 8Ω, 16Ω, 70V & 100V	4Ω, 8Ω, 16Ω, 70V & 100V
POWER SUPPLY	AC: 220-240V 50/60Hz DC: 24V (2 × 12V Car Battery)	AC: 220-240V 50/60Hz DC: 12V (12V Car Battery)	AC: 220-240V 50/60Hz DC: 12V (12V Car Battery)
POWER CONSUMPTION	AC: 220VA DC: 3A	AC: 250VA DC: 5.5A	AC: 180VA DC: 3A
DIMENSIONS	W420 × H135 × D290 mm	W420 × H135 × D295 mm	W355 × H133 × D285 mm
WEIGHT	10.50kg	11.30kg	8.53kg



PA Mixer Amplifiers



SSB-80[®]M

80 WATTS ■ AC & 12V DC Operation

- 5 Mic & 2 Aux Inputs.
- Preamp Output for connecting to a Booster Amplifier and for recording the programme.
- Cut type Bass & Treble controls.
- Instant transfer to DC power (Car Battery) if AC power fails.



SSB-60[®]EM

65 WATTS ■ AC & 12V DC Operation

- 4 Mic & 1 Aux Inputs.
- Preamp Output for connecting to a Booster Amplifier and for recording the programme.
- Cut type Bass & Treble Controls.
- Instant transfer to DC power (Car Battery) if AC power fails.



SSB-45[®]EM

45 WATTS ■ AC & 12V DC Operation

- 3 Mic & 1 Aux Inputs.
- Preamp Output for connecting to a Booster Amplifier and for recording the programme.
- Cut type Bass & Treble Controls.
- Instant transfer to DC power (Car Battery) if AC power fails.

All these models are compact, portable and ideal for most general purpose applications. These are ideal for use in small sized houses of worship and other similar applications. Since these also operate on 12V Car Battery, they are convenient for areas without continuous mains power supply

SPECIFICATIONS	SSB-80 [®] M	SSB-60 [®] EM	SSB-45 [®] EM
POWER OUTPUT	110W Max., 80W RMS at 10% THD 75W RMS at 5% THD, 60W RMS at 2% THD	90W Max., 65W RMS at 10% THD 60W RMS at 5% THD, 50W RMS at 2% THD	64W Max., 45W RMS at 10% THD 40W RMS at 5% THD, 30W RMS at 2% THD
OUTPUT REGULATION	≤ 2 dB, no load to full load at 1kHz	≤ 2 dB, no load to full load at 1kHz	≤ 2 dB, no load to full load at kHz
INPUT CHANNELS	5 × Mic 0.65mV/4.7kΩ, 2 × Aux 100mV/470kΩ	4 × Mic 0.65mV/4.7kΩ, 1 × Aux 100mV/470 kΩ	3 × Mic 0.65mV/4.7kΩ, 1 × Aux 100mV/470 kΩ
FREQUENCY RESPONSE	65-15,000Hz ±3dB	50-15,000Hz ±3dB	100-15,000Hz ±3dB
SIGNAL TO NOISE RATIO	60dB	60dB	60dB
TONE CONTROLS	Bass: -10dB at 100Hz, Treble: -10dB at 10kHz	Bass: -10dB at 100Hz, Treble: -10dB at 10kHz	Bass: -10dB at 100Hz, Treble: -10dB at 10kHz
OUTPUTS	Preamp 200mV/600Ω	Preamp 200mV/600Ω	Preamp 200mV/600Ω
SPEAKER OUTPUTS	4Ω, 8Ω, 16Ω, 70V & 100V	4Ω, 8Ω, 16Ω & 100V	4Ω, 8Ω, 16Ω & 100V
POWER SUPPLY	AC: 220-240V 50/60Hz DC: 12V (12V Car Battery)	AC: 220-240V 50/60Hz DC: 12V (12V Car Battery)	AC: 220-240V 50/60Hz DC: 12V (12V Car Battery)
POWER CONSUMPTION	AC: 180VA DC: 3A	AC: 160VA DC: 3A	AC: 110VA DC: 2A
DIMENSIONS	W355 × H133 × D285 mm	W350 × H120 × D265 mm	W280 × H120 × D270 mm
WEIGHT	7.83kg	7.00kg	4.80kg



UB-30M

25 WATTS ■ AC & 12V DC Operation

- 2 Mic & 1 Aux Input.
- Cut type tone control.
- 2 POWER SOURCE amplifier: AC mains and 12V DC (Car Battery).
- Provision of automatic changeover from AC to Battery operation ensuring continuity of program.
- Protection against wrong battery polarity.

Vehicle Amplifiers



PA-400^{DS}

40 WATTS ■ 12V DC Operation

- 2 Mic & 1 Aux Input.
- Built-in MP3 player with Bluetooth facility & remote control.
- Tone Control.
- 12V Car Battery Operation.
- Two Tone Siren (Wailing & Yelping) with volume control.
- Recommended for use with AHUJA Mic MM-60M & Horn Speakers SUH-25M/SUH-40.
- Amplifier mounting bracket supplied.
- Ideal for Police Vehicles, Crowd Control, Ambulances, Publicity Vans, Electioneering etc.



PA-400^S

40 WATTS ■ 12V DC Operation

- 2 Mic & 1 Aux Input.
- 12V Car Battery Operation.
- Two Tone Siren (Wailing & Yelping) with volume control.
- Recommended for use with AHUJA Mic MM-60M & Horn Speakers SUH-25M/SUH-40.
- Amplifier mounting bracket supplied.
- Ideal for Police Vehicles, Crowd Control, Ambulances, Publicity Vans, Electioneering etc.

SPECIFICATIONS	UB-30M	PA-400 ^{DS}	PA-400 ^S
POWER OUTPUT	30W RMS Max., 25W RMS at 10% THD	50W Max., 40W RMS at 10% THD	50W Max., 40W RMS at 10% THD
INPUT CHANNELS	2 × Mic 1.0mV/4.7kΩ, 1 × Aux 100mV/470kΩ	2 × Mic 1mV/4.7kΩ, 1 × Aux 100mV/330kΩ	2 × Mic 1mV/4.7kΩ, 1 × Aux 100mV/330kΩ
DIGITAL PLAYER	—	MP3 Player with USB Reader & Bluetooth	—
FREQUENCY RESPONSE	150-10,000Hz ±3dB	100-10,000Hz ±3dB	100-10,000Hz ±3dB
SIGNAL TO NOISE RATIO	60dB	60dB	60dB
SIREN	—	Two Tones	Two Tones
TONE CONTROLS	-10dB at 10kHz	-10dB at 10kHz	—
SPEAKER OUTPUTS	4Ω, 8Ω & 16Ω & 100V	4Ω, 100V Line	4Ω, 100V Line
POWER SUPPLY	AC: 220-240V 50/60Hz, DC: 12V (Car Battery)	12V DC (Car Battery)	12V DC (Car Battery)
POWER CONSUMPTION	AC: 80VA DC: 1.2A	—	—
DIMENSIONS	W180 × H80 × D260 mm	W190 × H80 × D240 mm	W180 × H80 × D240 mm
WEIGHT	3.00kg	2.30kg	2.10kg





PA-200DS

20 WATTS ■ 12V DC Operation

- 1 Mic Input with volume control.
- Built-in MP3 player with Bluetooth & AUX Input.
- Separate USB/AUX volume control with USB ON/OFF switch.
- 12V Car Battery Operation.
- Two Tone Siren (Wailing & Yelping) with volume control.
- Recommended for use with AHUJA Mic MM-60M & Horn Speakers EHC-10/SUH-15M.
- Complies in size with the DIN standard.
- Amplifier mounting bracket supplied alongwith.
- Ideal for Police Vehicles, Crowd Control, Ambulances, Publicity Vans, Electioneering etc.



PA-200S

20 WATTS ■ 12V DC Operation

- 1 Mic & 1 Aux Input with individual volume control.
- 12V Car Battery Operation.
- Two Tone Siren (Wailing & Yelping) with volume control.
- Recommended for use with AHUJA Mic MM-60M & Horn Speakers EHC-10/SUH-15M.
- Complies in size with the DIN standard.
- Amplifier mounting bracket supplied alongwith.
- Ideal for Police Vehicles, Crowd Control, Ambulances, Publicity Vans, Electioneering etc.



MPA-40S

22 WATTS ■ 12V DC Operation

- 1 Mic Input.
- 12V Motorcycle Battery Operation.
- Two Tone Siren (Wailing & Yelping) with volume control.
- Separate cable provided for connecting Blinking and Flashing patrol lights.
- Recommended AHUJA Mic MM-60M with 4 pin connector.
- Supplied with mounting brackets.
- Ideal for Police Motorcycles.

SPECIFICATIONS	PA-200DS	PA-200S	MPA-40S
POWER OUTPUT	30W Max., 20W RMS at 10% THD	30W Max., 20W RMS at 10% THD	22W Max., 16W RMS at 10% THD
INPUT CHANNELS	1 × Mic 5.0mV/4.7kΩ,	1 × Mic 5.0mV/4.7kΩ, 1 × Aux 100mV/330kΩ	Built-in Mic
DIGITAL PLAYER	MP3 Player with USB, BT and SD/MMC Card Reader, Ø3.5 mm AUX Input	—	—
FREQUENCY RESPONSE	250-10,000Hz ±3dB	250-10,000Hz ±3dB	100-10,000Hz ±3dB
SIGNAL TO NOISE RATIO	60dB	60dB	60dB
SIREN	Two Tones	Two Tones	Two Tones
SPEAKER OUTPUTS	4Ω/20W; 8Ω/12W	4Ω/20W; 8Ω/12W	4Ω Voice Coil
POWER SUPPLY	12V DC (Car Battery)	12V DC (Car Battery)	12V DC (Motorcycle Battery)
DIMENSIONS	W178 × H52 × D157 mm	W178 × H52 × D157 mm	Control Unit: W125 × H95 × D120 mm Horn Speaker: Dia 170 × (L190) mm
WEIGHT	1.10kg (with mounting clamp)	1.10kg (with mounting clamp)	Control Unit with Mic 730g Horn Speaker 1.95kg

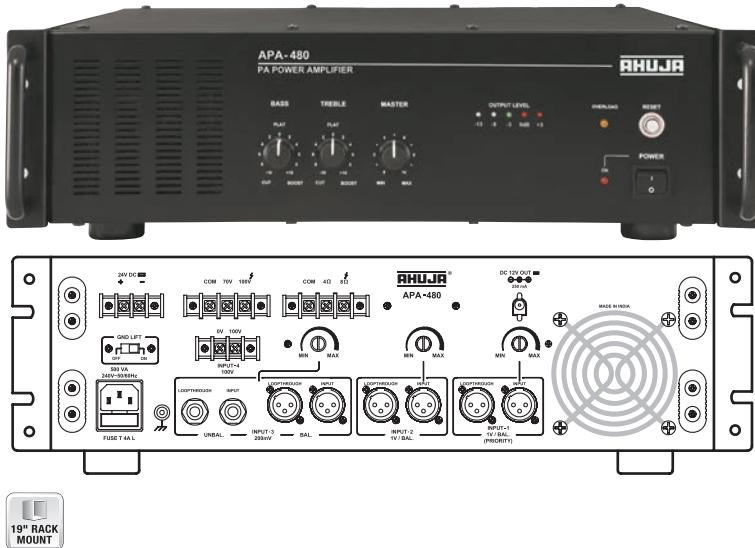

APA-480 600 WATTS ■ AC & 24V DC Operation

- 1x Line 200mV unbalanced input through 1/4" phone socket, 1xLine 200mV balanced input & 2xLine 1V balanced inputs through XLR connectors, one 1V input having priority over all other inputs.
- 100V input is provided for connecting another amplifier's output in long line applications.
- Ground lift switch provided at rear panel which helps reducing the hum that occurs due to multiple ground loops in the installations.
- Resettable circuit breaker for protection against overload and short circuit.
- Loop through output for connecting another booster amplifier.
- 482.6 mm(19") Rack mountable chassis.
- Instant transfer to DC power (Car Battery) if AC power fails.

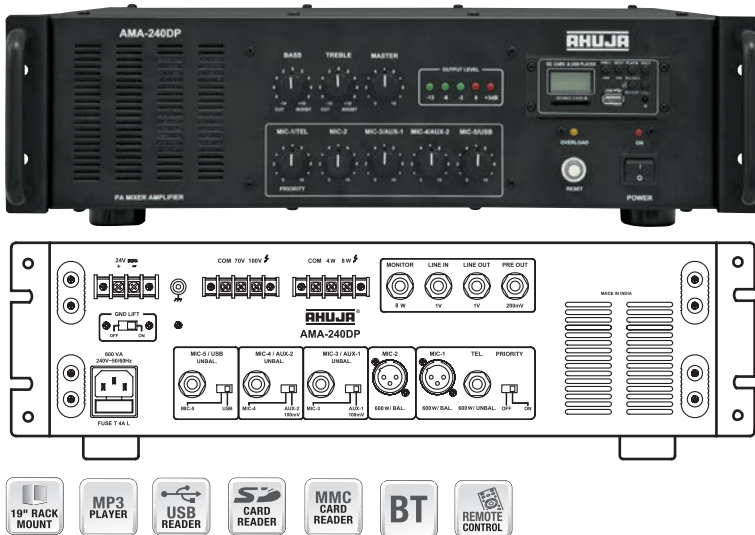

AMA-240DP 325 WATTS ■ AC & 24V DC Operation

- High quality mixer amplifier with built-in MP3 player in standard 482.6 mm (19") rack mountable chassis.
- 3 Unbalanced Mic inputs, 2 balanced Mic inputs, 2 Aux inputs, 1 Telephone & 1 balanced line Input.
- Mic 1 and Telephone input have selectable voice operated priority over all other inputs.
- MP3 playback facility can be used for playback of music recorded in MP3 format in USB pen drives or SD cards.
- Pre-amplifier Output (unbal.) and Line Output (bal.) for recording & connecting a booster amplifier.
- Ground lift switch provided at rear panel which helps reducing the hum that occurs due to multiple ground loops in the installations.
- Resettable circuit breaker for protection against overload and short circuit.
- Instant transfer to DC power (Car Battery) if AC power fails.

SPECIFICATIONS	APA-480	AMA-240DP
POWER OUTPUT	750W Max., 600W RMS at 10% THD 550W RMS at 5% THD, 500W RMS at 2% THD, 480W RMS at 1% THD	415W Max., 325W RMS at 10% THD, 240W RMS at 1% THD —
OUTPUT REGULATION	≤ 2 dB, no load to full load at 1kHz	≤ 2 dB, no load to full load at 1kHz
INPUT CHANNELS	1 × 200mV/470kΩ (unbal.), 1 × 200mV/50kΩ (bal.), 2 × 1V/50kΩ (bal.), 1 × 100V Input/50kΩ	3 × Mic 2.5mV/4.7kΩ (unbal.), 2 × Mic 2.0mV/2kΩ (bal.), 1 × Line 1V/50kΩ (Bal.), 2 × Aux 100mV/470kΩ, 1 × Telephone 150mV/10kΩ
FREQUENCY RESPONSE	50-15,000Hz ±3dB	50-15,000Hz ±3dB
SIGNAL TO NOISE RATIO	60dB	60dB
TONE CONTROLS	Bass: ±10dB at 100Hz, Treble: ±10dB at 10kHz	Bass: ±10dB at 100Hz, Treble: ±10dB at 10kHz
OUTPUTS	Loop through 2 × 200mV/600Ω, 2 × 1V/1kΩ	Preamp 200mV/600Ω (Unbal.), Line 1V/1kΩ (Bal.), Monitor 5V/8Ω
SPEAKER OUTPUTS	4Ω, 8Ω, 70V & 100V	4Ω, 8Ω, 70V & 100V
DIGITAL PLAYER	—	MP3 Player with USB, SD / MMC Card Reader & Bluetooth
POWER SUPPLY	AC: 220-240V 50/60Hz DC: 24V (2 × 12V Car Battery)	AC: 220-240V 50/60Hz DC: 24V (2 × 12V Car Battery)
POWER CONSUMPTION	AC: 1200VA DC: 15A	AC: 600VA DC: 7A
DIMENSIONS	W485 × H142 × D510 mm	W485 × H142 × D405 mm
WEIGHT	32.20kg	21.00kg



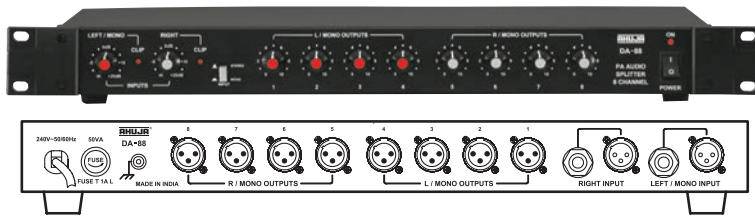

DA-88

AC Operation

- Compact and rugged professional line level signal splitter.
- Designed for use in a wide variety of indoor and outdoor PA applications.
- Accepts line level Stereo as well as Mono inputs through F/XLR connector as well as 6.3 mm (1/4") stereo phone jack sockets.
- Provides four stereo balanced outputs or eight mono balanced outputs through M/XLR connectors.
- Individual volume control for each input & output channel.
- Separate clip LED indicator for Left and Right input signal.
- Easy to operate Stereo/Mono push switch, provided on front panel.
- Operates on AC mains.
- 482.6 mm (19") rack mountable in 1U size and usable as a table top unit also.

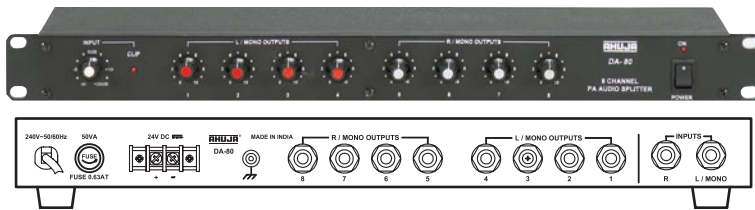

DA-80

AC & 24V DC Operation

- Sleek & compact 8-channel line signal splitter.
- Accepts line level Stereo/Mono input.
- Provides four line level stereo outputs or eight line level mono outputs.
- Individual volume controls for input and eight output channels.
- Clip LED for setting optimum distortion free input levels.
- Operates on AC mains and 24V DC Car Battery.
- 482.6 mm (19") rack mountable in 1U space and also usable as a table top unit.

SPECIFICATIONS	DA-88	DA-80
INPUT CHANNELS	2 × 100mV/20kΩ Balanced	2 × 100mV/47kΩ Unbalanced
OUTPUTS	8 × 1V/50Ω Balanced	8 × 1V/470Ω Unbalanced
FREQUENCY RESPONSE	20-20,000Hz ±3dB	20-20,000Hz ±3dB
DISTORTION	<0.1%	< 0.1%
SIGNAL TO NOISE RATIO	70dB	70dB
POWER SUPPLY	AC: 220-240V 50/60Hz	AC: 220-240V 50/60Hz, DC: 24V (2×12V Car Battery)
DIMENSIONS	W483 × H52 × D195 mm	W483 × H43 × D178 mm
WEIGHT	2.80kg	2.80kg



Hallmark of Reliability!



Amplifiers with built-in Digital Player

USB Flash Drives & SD Cards provide a reliable, lightweight and convenient medium for storing very large numbers of songs in MP3 format. Ahuja MP3 Digital Players are specially designed to reproduce, faithfully and with utmost fidelity, the music stored in MP3 format.

A wide range of highly reliable AHUJA PA Amplifiers are available with built-in MP3 Digital Players to enable easy & convenient music playback.

Applications

Offices | Coaching Classes | Shops | Campaigns | Mobile Publicity
Tourist Coaches | Restaurants

Dual Channel Power Amplifier with Digital Player

ZXA-500DP

250+250 WATTS ■ AC Operation

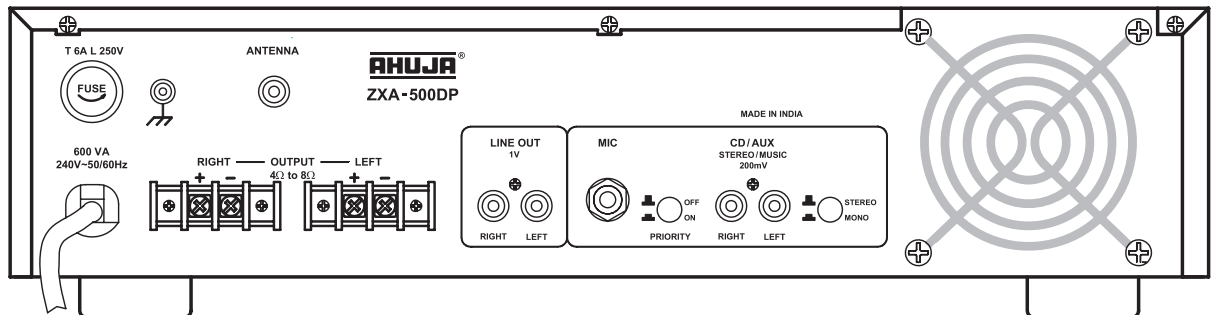

- Designed for use in wide variety of applications specially requiring high quality music.
- Professional dual channel power amplifier.
- 500 Watts rated output.
- Built-in MP3 play back facility with remote control. Backlit LCD display.
- Bluetooth and FM facility.
- Digital recorder facility.
- Cut-Boost type treble and bass control for tonal adjustment.
- Extensive built-in protection circuit for smooth and safe operation.

SPECIFICATIONS

ZXA-500DP

CONTINUOUS RATED POWER

STEREO/MONO 8Ω : 100W + 100W RMS, 4Ω : 180W + 180W RMS
2Ω : 250W + 250W RMS

THD + N < 1.0%

FREQUENCY RESPONSE (-1dB) 20-20,000Hz

POWER BANDWIDTH (0.5% THD) 20-20,000Hz

INPUTS Mic: Mono Phone Jack 6.3mm, CD/Aux: RCA Jack (L&R)

INPUT SENSITIVITY Mic: 5mV/4.7kΩ (unbal.), CD/Aux: 250mV/10kΩ (L&R) Stereo Mode

SIGNAL TO NOISE RATIO > 65dB

TONE CONTROLS Bass: ±10dB at 100Hz, Treble: ±10dB at 10kHz

CHANNEL SEPARATION > 60dB AT 1kHz

OUTPUT Line: 1V/1kΩ (L&R) through RCA Jack

DIGITAL PLAYER MP3 Recorder Player with USB, SD, MMC Card, Bluetooth & FM

PROTECTIONS Temperature, DC, RFI, Short Circuit, Built-in Limiter AC: Fuse 6A (T 6A L); ± DC: Fuse 2 × 8A (T 8A L) for each channel

OUTPUT CONNECTORS 2 × Heavy duty 2-Way terminal strip

COOLING DC Fan with Temperature Sensing

INDICATORS Power ON, Signal, Clip, Protect (Ch. L&R)

POWER CONSUMPTION (RATED) 600VA @ 220-240V ~ 50/60Hz

DIMENSIONS W393 × H108 × D375mm

WEIGHT 10.50kg

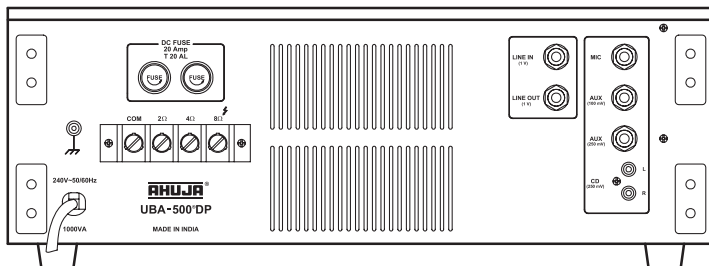
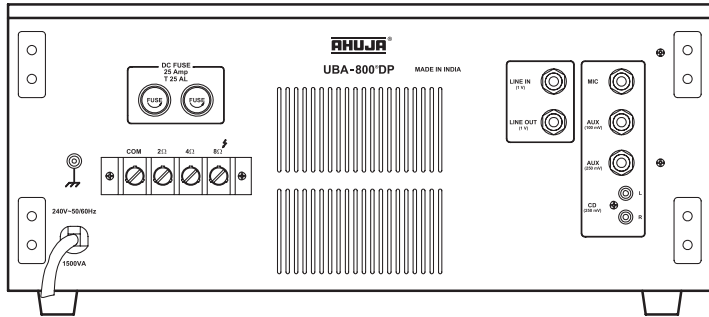

UBA-800®DP

800 WATTS ■ AC Operation

- Designed for use in a wide variety of PA applications and DJ performances.
- Built-in MP3 player with remote control for USB, SD/MMC card reader.
- Bluetooth facility.
- UBA-800 is a 800 Watts amplifier which can be connected to various input sources like a Microphone, PA Mixer, DJ Mixer, CD Player, Cassette Player, Keyboard etc.
- Bass and Treble controls provided for precise and accurate tonal setting of the programme.
- Line Input and Line Output have been provided to enable interconnections with other power amplifiers.
- Circuit Protector Device has been provided which safeguards the amplifier against overload and short circuit.
- The amplifier has built-in protection against over voltage in AC mains supply which is specially useful while operating on a DG Set.
- Indicator LEDs for Power, Signal, Temp, Overload and Fault conditions have been provided.
- 2Ω speaker matching provided in addition to 4Ω & 8Ω.

UBA-500®DP

500 WATTS ■ AC Operation

- Designed for use in a wide variety of PA applications and DJ performances.
- Built-in MP3 player with remote control for USB, SD/MMC card reader.
- Bluetooth facility.
- UBA-500DP is a 500 Watts amplifier which can be connected to various input sources like a Microphone, PA Mixer, DJ Mixer, CD Player, Cassette Player, Keyboard etc.
- Bass and Treble controls provided for precise and accurate tonal setting of the programme.
- All other features are similar to UBA-800DP.

SPECIFICATIONS	UBA-800®DP	UBA-500®DP
POWER OUTPUT	1150W RMS Max., 800W RMS at 10%THD 770W RMS at 5% THD 725W RMS at 2% THD	650W RMS Max., 500W RMS at 10%THD 475W RMS at 5% THD 450W RMS at 2% THD
OUTPUT REGULATION	≤ 2dB, no load to full load at 1kHz	≤ 2dB, no load to full load at 1kHz
INPUT CHANNELS	1 × Mic 1mV / 4.7kΩ, 1 × Aux 100mV / 470kΩ, 1 × Aux 250mV / 20kΩ 1 × CD 250mV / 20kΩ, 1 × Line 1V / 20kΩ	1 × Mic 1mV / 4.7kΩ, 1 × Aux 100mV / 470kΩ, 1 × Aux 250mV / 20kΩ 1 × CD 250mV / 20kΩ, 1 × Line 1V / 20kΩ
FREQUENCY RESPONSE	50Hz – 18,000Hz ±3dB	50Hz – 18,000Hz ±3dB
SIGNAL TO NOISE RATIO	60dB	60dB
TONE CONTROLS	Bass (100Hz) : ± 8dB Treble (10kHz) : ± 8dB	Bass (100Hz) : ± 8dB Treble (10kHz) : ± 8dB
LINE OUTPUT	1V/1kΩ	1V/1kΩ
SPEAKER OUTPUT	2Ω, 4Ω & 8Ω	2Ω, 4Ω & 8Ω
DIGITAL PLAYER	MP3 Player with USB, SD, MMC Card Reader, Bluetooth	MP3 Player with USB, SD and MMC Card Reader, Bluetooth
POWER SUPPLY	AC: 220-240V 50/60Hz	AC: 220-240V 50/60Hz
PROTECTIONS	2 × 25A fuse in ± DC supply, 8A circuit breaker in AC mains Protected against high AC mains voltage, overload & temperature	2 × 20A fuse in ± DC supply, 5A circuit breaker in AC mains Protected against high AC mains voltage, overload & temperature
POWER CONSUMPTION	1500 VA	1000 VA
DIMENSIONS	W482 × H186 × D512 mm	W482 × H166 × D435 mm
WEIGHT	33.10kg	22.60kg



Two Zone PA Mixer Amplifiers with Digital Player

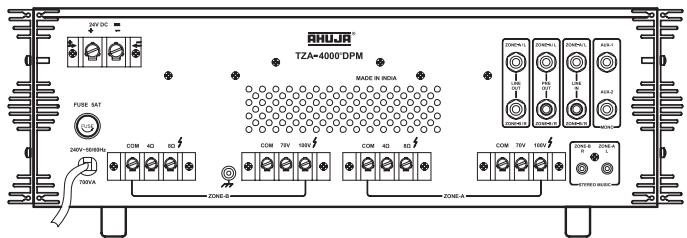
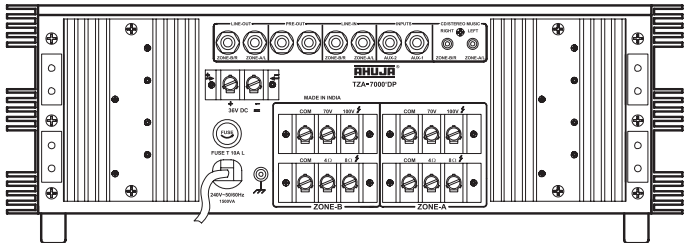

TZA-7000®DP

700 WATTS ■ AC & 36V DC Operation

- 6 Mic, 2 Aux Inputs and CD/Stereo music input (L&R)
- Built-in MP3 player with remote control and LCD display for USB, SD/MMC card reader.
- Bluetooth facility.
- Stereo/Mono switch to change ambience of MP3 music player & CD/Stereo music for DJ programmes.
- Facilitates connection and operation of two separate groups of speakers simultaneously. Ideal for Places of Worship.
- Line Input & Output on each zone for connecting to a PA Mixer and Booster Amplifier respectively. Preamplifier output for recording.
- Box Speaker/Driver Unit selector switch for each zone. Bass boost defeated at Driver Unit position for safer operation of driver units. Zone On/Off facility.
- Resettable circuit breaker for protection against overload and short circuit.
- Instant transfer to DC power (Car Battery) if AC power fails.



TZA-4000®DPM

400 WATTS ■ AC & 24V DC Operation

- 6 Mic, 2 Aux Inputs and CD/Stereo input (L&R).
- Built-in MP3 player with remote control and LCD display for USB, SD/MMC card reader.
- Bluetooth facility.
- Stereo/Mono switch to change ambience of MP3 music player and CD/Stereo music for DJ programmes.
- Separate USB level control provided.
- Facilitates connection and operation of two separate groups of speakers simultaneously. Ideal for Places of Worship.
- Line Input & Output on each zone for connecting to a PA Mixer and Booster Amplifier respectively. Preamplifier output for recording.
- Box Speaker/Driver Unit selector switch for each zone. Bass boost defeated at Driver Unit position for safer operation of driver units. Zone On/Off facility.
- Resettable circuit breaker for protection against overload and short circuit.
- Instant transfer to DC power (Car Battery) if AC power fails.



SPECIFICATIONS	TZA-7000®DP	TZA-4000®DPM
POWER OUTPUT	500W + 500W Max., 350W + 350W RMS at 10% THD 300W + 300W RMS at 5% THD, 280W + 280W RMS at 2% THD	300W + 300W Max., 200W + 200W RMS at 10% THD 180W + 180W RMS at 5% THD, 165W + 165W RMS at 2% THD
OUTPUT REGULATION	≤ 2 dB, no load to full load at 1kHz	≤ 2 dB, no load to full load at 1kHz
INPUT CHANNELS	Mic/Aux: 6 × Mic 0.6mV/4.7kΩ, 2 × Aux 100mV/470kΩ Stereo Music Mode: L/R 200mV/100kΩ, Line L/R 1V/20kΩ	Mic/Aux: 6 × Mic 0.6mV/4.7kΩ, 2 × Aux 100mV/470kΩ Stereo Music Mode: L/R 200mV/100kΩ, Line L/R 1V/50kΩ
FREQUENCY RESPONSE	50-15,000Hz ± 3dB	50-15,000Hz ± 3dB
SIGNAL TO NOISE RATIO	60dB	60dB
TONE CONTROLS	Bass: ±10dB at 100Hz, Treble: ±10dB at 10kHz	Bass: ±10dB at 100Hz, Treble: ±10dB at 10kHz
OUTPUT	Preamp 200mV/600Ω, Line 1V/1kΩ	Preamp 200mV/600Ω, Line 1V/1kΩ
SPEAKER OUTPUT	4Ω, 8Ω, 70V & 100V for each zone	4Ω, 8Ω, 70V & 100V for each zone
DIGITAL PLAYER	MP3 Player with USB, SD and MMC Card Reader, Bluetooth	MP3 Player with USB, SD and MMC Card Reader, Bluetooth
POWER SUPPLY	AC: 220-240V 50/60Hz DC: 36V (3 × 12V Car Battery)	AC: 220-240V 50/60Hz DC: 24V (2 × 12V Car Battery)
POWER CONSUMPTION	AC: 1100VA DC: 13A	AC: 700VA DC: 9A
DIMENSIONS	W510 × H185 × D470 mm	W510 × H172 × D385 mm
WEIGHT	40.00kg	24.20kg

Two Zone PA Mixer Amplifiers with Digital Player

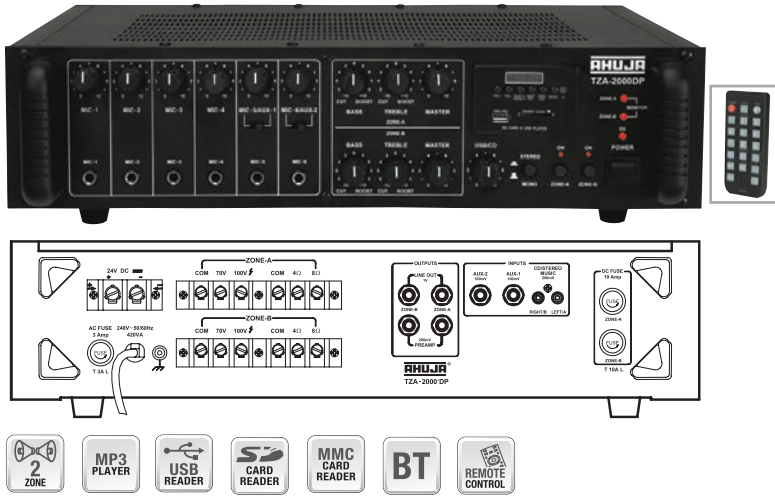

TZA-2000®DP

200 WATTS ■ AC & 24V DC Operation

- 6 Mic, 2 Aux Inputs and CD/Stereo input (L&R)
- Built-in MP3 player with remote control for USB, SD/MMC card reader.
- Bluetooth facility.
- TZA-2000DP is ideal for medium sized installations such as in places of worship where two separate groups of speakers are needed to be connected.
- User has a choice to connect both the zones to 100V (LMT) type speakers, or 100V speakers to one zone and low impedance type speakers to the other zone. Both the zones can also be connected to low impedance type speakers.
- Easy accessibility of DC fuses fitted on rear panel.
- Instant transfer to DC power (Car Battery) if AC power fails.

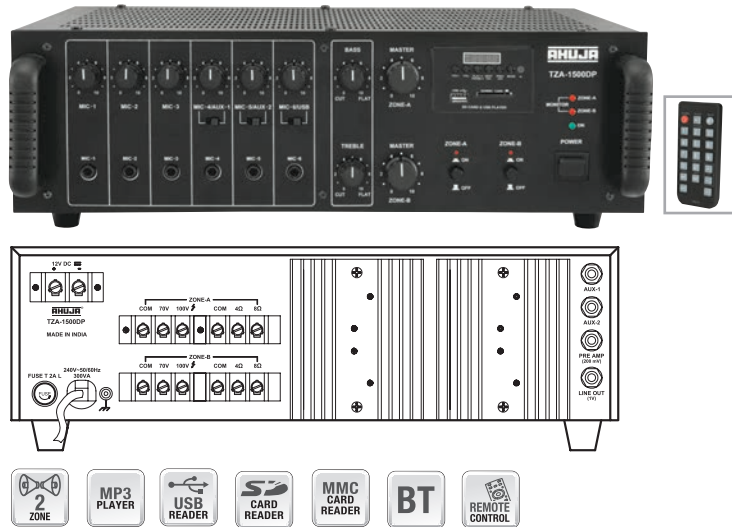

TZA-1500DP

160 WATTS ■ AC & 12V DC Operation

- 6 Mic, 2 Aux Inputs.
- Built-in MP3 player with remote control for USB, SD/MMC card reader.
- Bluetooth facility.
- Preamplifier and Line Output for connecting to a Booster Amplifier and for recording the programme.
- TZA-1500DP is ideal for medium sized installations such as in places of worship where two separate groups of speakers are needed to be connected.
- User has a choice to connect both the zones to 100V (LMT) type speakers, or 100V speakers to one zone and low impedance type speakers to the other zone. Both the zones can also be connected to low impedance type speakers.
- Instant transfer to DC power (Car Battery) if AC power fails.

SPECIFICATIONS	TZA-2000®DP	TZA-1500DP
POWER OUTPUT	130W + 130W Max., 100W + 100W RMS at 10% THD 90W + 90W RMS at 5% THD, 80W + 80W RMS at 2% THD	100W + 100W Max., 80W + 80W RMS at 10% THD 70W + 70W RMS at 5% THD, 60W + 60W RMS at 2% THD
OUTPUT REGULATION	≤ 2 dB, no load to full load at 1kHz	≤ 2 dB, no load to full load at 1kHz
INPUT CHANNELS	Mono: 6 × Mic 0.65mV/4.7kΩ, 2 × Aux 100mV/470kΩ Stereo: L/R 250mV/47kΩ	6 × Mic 0.6mV/4.7kΩ, 2 × Aux 100mV/470kΩ —
FREQUENCY RESPONSE	50-15,000Hz ±3dB	65-15,000Hz ±3dB
SIGNAL TO NOISE RATIO	60dB	60dB
TONE CONTROLS	Bass: ±10dB at 100Hz, Treble: ±10dB at 10kHz	Bass: -10dB at 100Hz, Treble: -10dB at 10kHz
OUTPUT	Preamp 200mV/600Ω, Line 1V/1kΩ	Preamp 200mV/600Ω, Line 1V/1kΩ
SPEAKER OUTPUT	4Ω, 8Ω, 70V & 100V for each zone	4Ω, 8Ω, 70V & 100V for each zone
DIGITAL PLAYER	MP3 Player with USB, SD and MMC Card Reader, Bluetooth	MP3 Player with USB, SD and MMC Card Reader, Bluetooth
POWER SUPPLY	AC: 220-240V 50/60Hz DC: 24V (2 × 12V Car Battery)	AC: 220-240V 50/60Hz DC: 12V (12V Car Battery)
POWER CONSUMPTION	AC: 420VA DC: 6.5A	AC: 300VA DC: 6A
DIMENSIONS	W500 × H140 × D345 mm	W460 × H155 × D310 mm
WEIGHT	17.50kg	14.50kg



PA Mixer Amplifiers with Digital Player

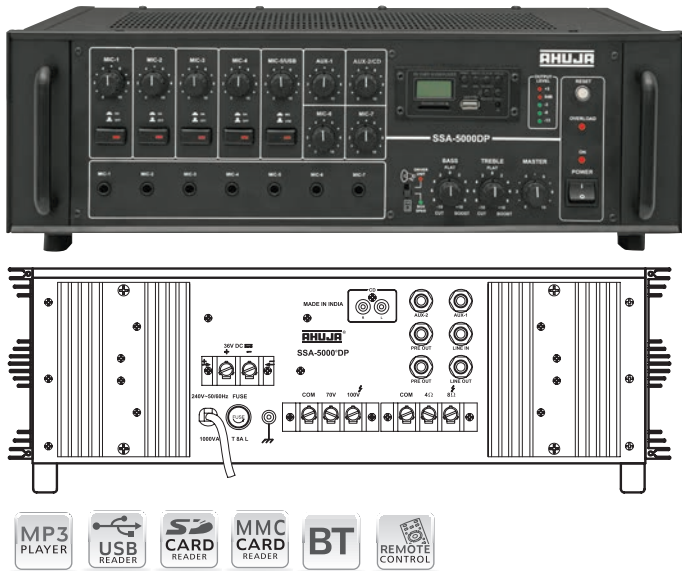

SSA-5000® DP

500 WATTS ■ AC & 36V DC Operation

- 7 Mic & 2 Aux Inputs. With Built-in MP3 player.
- Preamplifier and Line Output for connecting to a Booster Amplifier.
- Bluetooth facility.
- Line Input for connecting the output from any external PA Mixer or another amplifier.
- Resettable circuit breaker for protection against overload and short circuit.
- Instant transfer to DC power (Car Battery) if AC power fails.
- Box Speaker/Driver Unit selector switch. Bass boost defeated at Driver Unit position for safer operation of driver units.

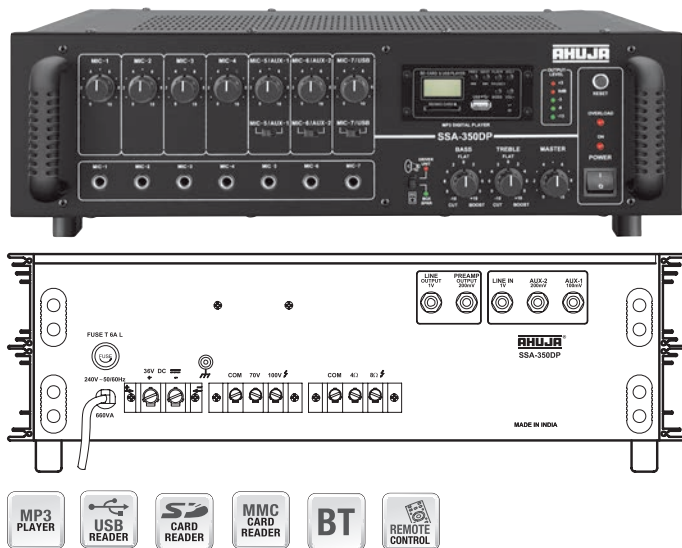

SSA-350DP

350 WATTS ■ AC & 36V DC Operation

- 7 Mic & 2 Aux Inputs.
- Preamplifier and Line Output for connecting to a Booster Amplifier and for recording the programme.
- Line Input for connecting the output from any external PA mixer or permitting SSA-350DP to be used as a Booster Power Amplifier.
- Resettable circuit breaker for protection against overload and short circuit.
- Box Speaker/Driver Unit selector switch. Bass boost defeated at Driver Unit position for safer operation of driver units.
- Instant transfer to DC power (Car Battery) if AC power fails.
- Built-in MP3 player facility with USB, SD and MMC Card Reader, Bluetooth.

SPECIFICATIONS	SSA-5000® DP	SSA-350DP
POWER OUTPUT	750W Max., 500W RMS at 10% THD 450W RMS at 5% THD, 415W RMS at 2% THD	450W Max., 350W RMS at 10% THD ; 320W RMS at 5% THD, 300W RMS at 2% THD
OUTPUT REGULATION	≤ 2 dB, no load to full load at 1kHz	≤ 2 dB, no load to full load at 1kHz
INPUT CHANNELS	7 × Mic 0.8mV/4.7kΩ, 2 × Aux 100mV/470 kΩ, 1 × CD 200mV/50 kΩ, 1 × Line 1V/50kΩ	7 × Mic 0.8mV/4.7kΩ, 1 × Aux 100mV/470kΩ; 1 × Aux 200mV/470kΩ, 1 × Line 1V/50kΩ
FREQUENCY RESPONSE	50-15,000Hz ±3dB	50-15,000Hz ±3dB
SIGNAL TO NOISE RATIO	60dB	60dB
TONE CONTROLS	Bass: ±10dB at 100Hz, Treble: ±10dB at 10kHz	Bass: ±10dB at 100Hz, Treble: ±10dB at 10kHz
OUTPUT	Preamp 200mV/600Ω, Line 1V/1kΩ	Preamp 200mV/600Ω, Line 1V/1kΩ
SPEAKER OUTPUT	4Ω, 8Ω, 70V & 100V	4Ω, 8Ω, 70V & 100V
DIGITAL PLAYER	MP3 Player with USB, SD and MMC Card Reader, Bluetooth	MP3 Player with USB, SD and MMC Card Reader, Bluetooth
POWER SUPPLY	AC: 220-240V 50/60Hz, DC: 36V (3 × 12V Car Battery)	AC: 220-240V 50/60Hz DC: 36V (3 × 12V Car Battery)
POWER CONSUMPTION	AC: 1000VA DC: 8A	AC: 660VA DC: 6A
DIMENSIONS	W510 × H172 × D385 mm	W480 × H160 × D360 mm
WEIGHT	27.00kg	18.96kg

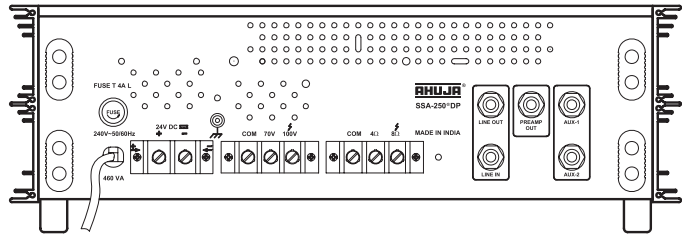

SSA-250® DP

250 WATTS ■ AC & 24V DC Operation

- 6 Mic & 2 Aux Inputs. With Built-in MP3 player.
- Bluetooth facility.
- Preamplifier and Line Output for connecting to a Booster Amplifier and for recording the programme.
- Line Input for connecting the output from any external PA Mixer or another Amplifier.
- Resettable circuit breaker for protection against overload and short circuit.
- Instant transfer to DC power (Car Battery) if AC power fails.
- Box Speaker/Driver Unit selector switch. Bass boost defeated at Driver Unit position for safer operation of driver units.

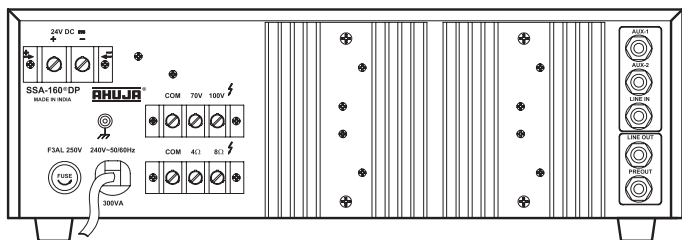

SSA-160® DP

160 WATTS ■ AC & 24V DC Operation

- 5 Mic & 2 Aux Inputs. With Built-in MP3 player.
- Bluetooth facility.
- Preamplifier and Line Output for connecting to a Booster Amplifier and for recording the programme.
- Line Input for connecting the output from any external PA Mixer or another Amplifier.
- Resettable circuit breaker for protection against overload and short circuit.
- Instant transfer to DC power (Car Battery) if AC power fails.
- Box Speaker/Driver Unit selector switch. Bass boost defeated at Driver Unit position for safer operation of driver units.
- 5 LED array for output level monitoring.

SPECIFICATIONS	SSA-250® DP	SSA-160® DP
POWER OUTPUT	300W Max., 250W RMS at 10% THD 220W RMS at 5% THD, 200W RMS at 2% THD	220W Max., 160W RMS at 10% THD 140W RMS at 5% THD, 120W RMS at 2% THD
OUTPUT REGULATION	≤ 2 dB, no load to full load at 1kHz	≤ 2 dB, no load to full load at 1kHz
INPUT CHANNELS	6 × Mic 0.65mV/4.7kΩ, 2 × Aux 100mV/470 kΩ, 1 × Line 1V/50kΩ	5 × Mic 0.65mV/4.7kΩ, 2 × Aux 100mV/470 kΩ, 1 × Line 1V/50kΩ
FREQUENCY RESPONSE	50-15,000Hz ±3dB	50-15,000Hz ±3dB
SIGNAL TO NOISE RATIO	60dB	60dB
TONE CONTROLS	Bass: ±10dB at 100Hz, Treble: ±10dB at 10kHz	Bass: ±10dB at 100Hz, Treble: ±10dB at 10kHz
OUTPUT	Preamp 200mV/600Ω, Line 1V/1kΩ	Preamp 200mV/600Ω, Line 1V/1kΩ
SPEAKER OUTPUT	4Ω, 8Ω, 70V & 100V	4Ω, 8Ω, 70V & 100V
DIGITAL PLAYER	MP3 Player with USB, SD and MMC Card Reader, Bluetooth	MP3 Player with USB, SD and MMC Card Reader, Bluetooth
POWER SUPPLY	AC: 220-240V 50/60Hz, DC: 24V (2 × 12V Car Battery)	AC: 220-240V 50/60Hz, DC: 24V (2 × 12V Car Battery)
POWER CONSUMPTION	AC: 460VA DC: 6A	AC: 300VA DC: 4A
DIMENSIONS	W450 × H160 × D340 mm	W426 × H155 × D325 mm
WEIGHT	16.00kg	13.30kg



PA Mixer Amplifiers with Digital Player

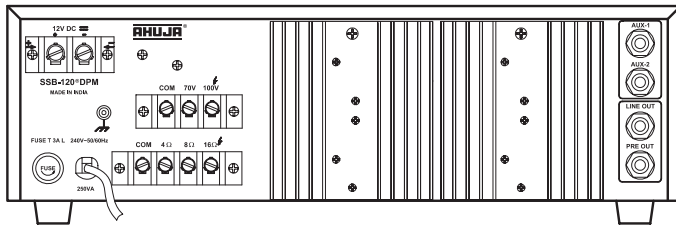

SSB-120®DPM

120 WATTS ■ AC & 12V DC Operation

- 5 Mic & 2 Aux Inputs.
- Built-in MP3 player with remote control for USB, SD/MMC card reader.
- Bluetooth facility.
- Line output for connecting to a Booster Amplifier and Preamplifier Output for recording the programme.
- Cut and Boost type Bass & Treble controls.
- Instant transfer to DC power (Car Battery) if AC power fails.
- 5 LED array for output level monitoring.

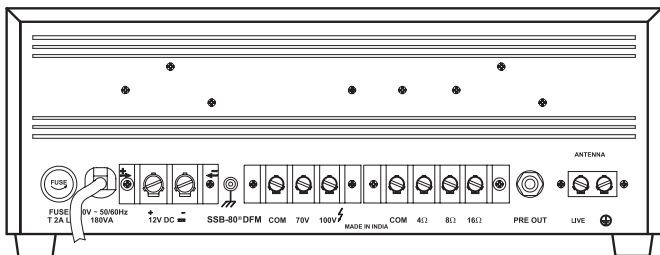

SSB-80®DFM

80 WATTS ■ AC & 12V DC Operation

- 3 Mic & 1 Aux Inputs.
- Built-in MP3 player with remote control for USB, SD/MMC card reader.
- Bluetooth and FM facility.
- Preamplifier Output for connecting to a Booster Amplifier and for recording the programme.
- Cut & Boost type Bass & Treble controls.
- Instant transfer to DC power (Car Battery) if AC power fails.

SPECIFICATIONS

	SSB-120®DPM	SSB-80®DFM
POWER OUTPUT	160W Max., 120W RMS at 10% THD 105W RMS at 5% THD, 95W RMS at 2% THD	110W Max., 80W RMS at 10% THD 75W RMS at 5% THD, 60W RMS at 2% THD
OUTPUT REGULATION	≤ 2 dB, no load to full load at 1kHz	≤ 2 dB, no load to full load at 1kHz
INPUT CHANNELS	5 × Mic 0.65mV/4.7kΩ, 2 × Aux 100mV/470 kΩ	3 × Mic 1mV/4.7kΩ, 1 × Aux 100mV/470 kΩ
FREQUENCY RESPONSE	50-15,000Hz ±3dB	65-15,000Hz ±3dB
SIGNAL TO NOISE RATIO	60dB	60dB
TONE CONTROLS	Bass: ±8dB at 100Hz, Treble: ±8dB at 10kHz	Bass: ±8dB at 100Hz, Treble: ±8dB at 10kHz
OUTPUTS	Preamp 200mV/600Ω, Line 1V/1kΩ	Preamp: 200mV/600Ω
SPEAKER OUTPUTS	4Ω, 8Ω, 16Ω, 70V & 100V	4Ω, 8Ω, 16Ω, 70V & 100V
DIGITAL PLAYER	MP3 Player with USB, SD & MMC Card Reader, Bluetooth	MP3 Player with USB, SD & MMC Card Reader, Bluetooth & FM
POWER SUPPLY	AC: 220-240V 50/60Hz, DC: 12V (12V Car Battery)	AC: 220-240V 50/60Hz, DC: 12V (12V Car Battery)
POWER CONSUMPTION	AC: 250VA DC: 5.5A	AC: 180VA DC: 3A
DIMENSIONS	W420 × H135 × D275 mm	W355 × H133 × D285 mm
WEIGHT	10.30kg	8.43kg

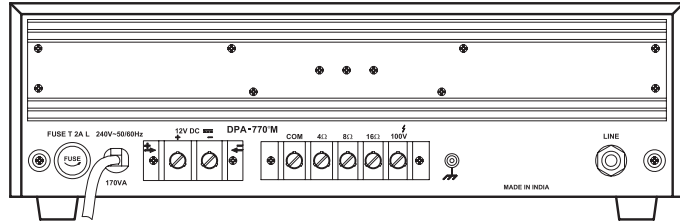

DPA-770®M

75 WATTS ■ AC & 12V DC Operation

- 4 Mic & 1 Aux Input.
- Built-in MP3 player with USB reader and remote control.
- Bluetooth facility.
- Line Output for connecting to a Booster Amplifier.
- Cut and Boost type Bass & Treble controls.
- Instant transfer to DC Power (Car Battery) if AC power fails.

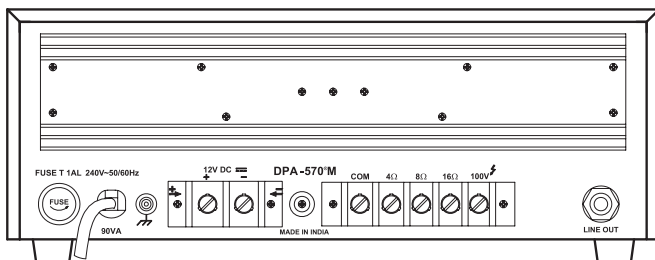

DPA-570®M

50 WATTS ■ AC & 12V DC Operation

- 3 Mic & 1 Aux Input.
- Built-in MP3 player with USB reader and remote control.
- Bluetooth facility.
- Line Output for connecting to a Booster Amplifier.
- Cut and Boost type Bass & Treble controls.
- Instant transfer to DC Power (Car Battery) if AC power fails.

SPECIFICATIONS

	DPA-770®M	DPA-570®M
POWER OUTPUT	100W Max., 75W RMS at 10% THD, 70W RMS at 5% THD	75W Max., 50W RMS at 10% THD, 45W RMS at 5% THD
OUTPUT REGULATION	≤ 2 dB, no load to full load at 1kHz	≤ 2 dB, no load to full load at 1kHz
INPUT CHANNELS	4 × Mic. 0.6mV/4.7kΩ, 1 × Aux 100mV/330kΩ	3 × Mic 0.6mV/4.7kΩ, 1 × Aux 100mV/330kΩ
FREQUENCY RESPONSE	50-15,000Hz ±3dB	50-15,000Hz ±3dB
SIGNAL TO NOISE RATIO	55dB	55dB
TONE CONTROLS	Bass: -10dB +7dB at 100Hz, Treble: -10dB +7dB at 10kHz	Bass: ±10dB at 100Hz, Treble: ±10dB at 10kHz
OUTPUTS	Line: 1V/3.5kΩ	Line: 400mV/3.5kΩ
SPEAKER OUTPUTS	4Ω, 8Ω, 16Ω & 100V	4Ω, 8Ω, 16Ω & 100V
DIGITAL PLAYER	MP3 Player with USB, SD, MMC Card Reader & Bluetooth	MP3 Player with USB, SD, MMC Card Reader & Bluetooth
POWER SUPPLY	AC: 220-240V 50/60Hz, DC: 12V (12V Car Battery)	AC: 220-240V 50/60Hz, DC: 12V (12V Car Battery)
POWER CONSUMPTION	AC: 170VA DC: 3A	AC: 90VA DC: 3.1A
DIMENSIONS	W385 × H125 × D300 mm	W305 × H120 × D305 mm
WEIGHT	8.80kg	6.20kg



PA Mixer Amplifiers with Digital Player



DPA-370®

30 WATTS ■ AC & 12V DC Operation

- 2 Mic & 1 Aux Input.
- Built-in MP3 player with USB reader and remote control.
- Bluetooth facility.
- Line Output for connecting to a Booster Amplifier.
- Cut type tone control.
- Instant transfer to DC Power (Car Battery) if AC power fails.

SPECIFICATIONS	DPA-370®
POWER OUTPUT	37W Max., 30W RMS at 10% THD, 27W RMS at 5% THD
OUTPUT REGULATION	≤ 2 dB, no load to full load at 1kHz
INPUT CHANNELS	2 × Mic. 0.5mV/2.5kΩ, 1 × Aux 50mV/330kΩ
FREQUENCY RESPONSE	100-12,000Hz ±3dB
SIGNAL TO NOISE RATIO	58dB
TONE CONTROLS	Tone: -10dB at 10kHz
OUTPUTS	Line: 250mV/3.5kΩ
SPEAKER OUTPUTS	4Ω, 8Ω, 16Ω & 100V
DIGITAL PLAYER	MP3 Player with USB Reader & Bluetooth
POWER SUPPLY	AC: 220-240V 50/60Hz, DC: 12V (12V Car Battery)
POWER CONSUMPTION	AC: 70VA DC: 2.7A
DIMENSIONS	W230 × H95 × D285 mm
WEIGHT	4.50kg

Digital Player/Recorder



ADP-30R

200mV ■ AC & 12V DC Operation

- Designed for use in a wide variety of PA applications.
- Built-in MP3 recorder player with LCD display supplied with remote control and with built-in facility of USB, SD, MMC card.
- Bluetooth facility.
- ADP-30R has a Preamp output for connecting to Stereo or Mono input of another amplifier and a REC input for recording the preamp output of another amplifier.
- Provision for automatic changeover from AC to Battery Operation ensures continuity of program (if 12V battery is connected).
- Protection provided against the reverse polarity of battery connections.

SPECIFICATIONS	ADP-30R
INPUT CHANNELS	REC Input 200mV Left & Right
FREQUENCY RESPONSE	20-20,000Hz ± 1dB
SIGNAL TO NOISE RATIO	60dB
OUTPUT	200mV/600Ω Mono / Stereo
DIGITAL PLAYER	MP3 Recorder Player with USB, SD, MMC Card & Bluetooth
POWER SUPPLY	AC: 220-240V 50/60Hz DC: 12V (12V Car Battery)
POWER CONSUMPTION	AC: 22VA DC: 500mA
DIMENSIONS	W152 × H81 × D165 mm
WEIGHT	1.20kg

85
YEARS+
SINCE 1940

Hallmark of Reliability!



Intelligent Paging Systems

Paging Systems are used to address, inform and alert people in public areas as well as inside buildings. Zonal Paging Systems are specially useful as they allow announcements to be made in selected areas only.

AHUJA Zonal Paging Systems are a set of reliable, sophisticated, user-friendly products, designed with many innovative safety and convenience features for a wide range of applications.

Applications

Shopping Malls | Schools & Colleges | Hotels | Multistorey Buildings

Offices | Factories | Railway Stations | Airports | Hospitals

APM-201RM

Remote Paging Microphone



A high performance 12 zone paging console housed in an elegant aluminium housing. It works with APM-202CU to make a 6 or 12 zone zonal paging system.

- 12 Zone Paging Mic Console with a 400 mm (16") gooseneck.
- 12 Zone Selector Switches, plus ALL CALL switch
- Separate Mic ON/OFF switch.
- LED indication of zone selection.
- RESET switch to reset all zone selections.
- Group selection facility.
- Built-in chime circuit.
- Chime & Mic level controls.
- Secure 8 pin lockable connectors.
- Can be used with one APM-202CU to make a 6 zone paging system, or with two nos APM-202CU to make a 12 zone paging system.
- Operates on 24V DC supply from APM-202CU.

SPECIFICATIONS	APM-201RM
OUTPUT LEVEL	1V Balanced (nominal).
SWITCHES	12 Zone Selectors, All Call, Chime, Group 1, Group 2, Mic ON/OFF, Reset
CONTROLS	Mic level, chime level
POWER SUPPLY	DC 24V (from APM-202CU)
DIMENSIONS	W285 × H530 × D160 mm
WEIGHT	1.60kg

APM-202CU

Control Unit ■ AC & 24V DC Operation

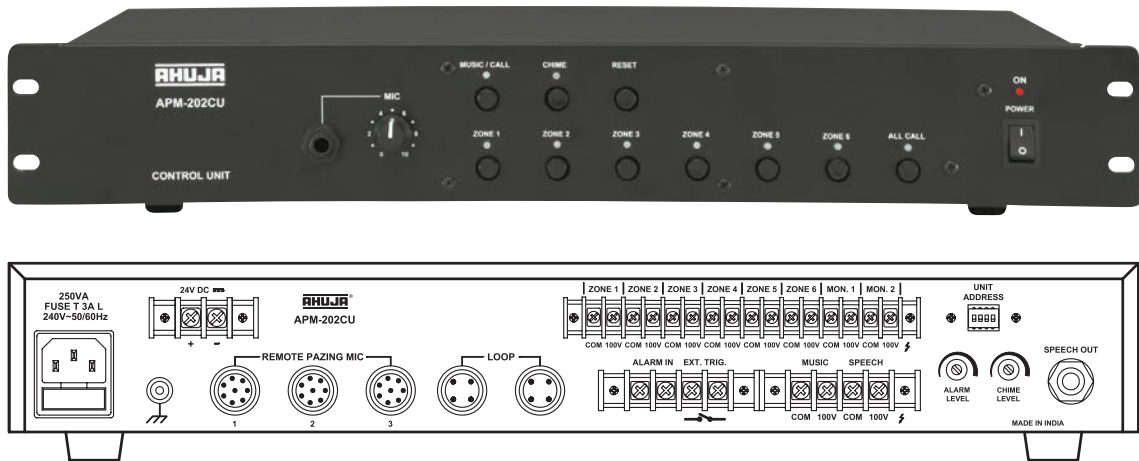

- APM-202CU is a rack mounting switcher / control unit which works with APM-201RM and upto 2 amplifiers to form a 6 zone paging system with multi level priority and switchable background music.
- 6 Zone Switcher / Paging Control Unit for use with APM-201RM.
- 6 Zone Selector switches, plus ALL CALL switch.
- Provision for two 100V input signals, one for speech and one for background music.
- Priority of speech over background music.
- Provision for routing background music source to selected zones.
- Provision to make announcements from the control unit.
- Status monitoring of all zones.
- Provision for emergency trigger input and alarm input with highest priority.
- Standard 482.6 mm (19") rack mounting chassis.

SPECIFICATIONS	APM-202CU
SWITCHING SIGNAL LEVEL	100V (Nominal)
INPUTS (Nominal)	3 × APM-201RM (1V/10k balanced), 1 × Mic (1mV/4.7k), Speech Amp (100V), Music Amp (100V), Alarm (100mV).
SWITCHES	6 Zone Selector switches, All Call, Chime, Reset, Music/Call Selector, Power ON/OFF.
CONTROLS	Mic Level, Chime level, Alarm level
POWER SUPPLY	AC 220-240V, 50/60Hz ; DC 24V (2 × 12V Car Battery)
DIMENSIONS	W483 × H75 × D300 mm
WEIGHT	4.80kg



SSW-16M

16 Channel Zone Selector ■ AC & 24V DC Operation

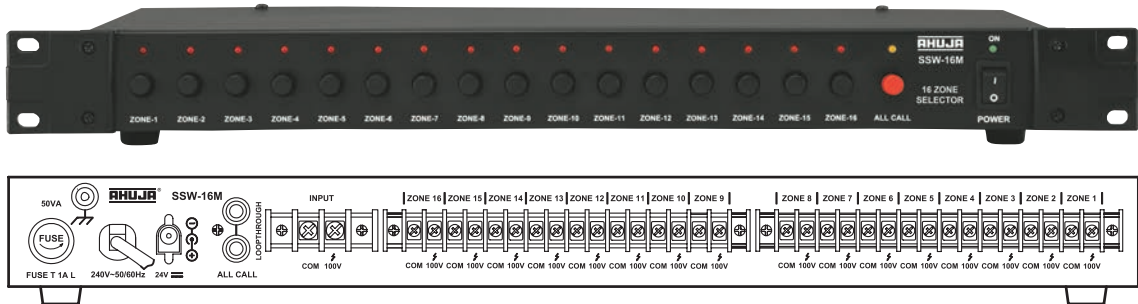

Compact and reliable manual zone selector with provision for switching a 100V audio signal to one or more of upto 16 zones.

- 1 x 100V Input, 16 x 100V Outputs, Manually Switchable.
- When multiple units of SSW-16M are used, ALL CALL activation is possible from any one SSW-16M, by using LOOP THROUGH facility.
- Built-in relay for ALL CALL.
- LED indication of selected zones.

SPECIFICATIONS	SSW-16M
INPUT	1 × 100V (nominal)
OUTPUTS	16 × 100V (nominal)
SWITCHES	16 Zone Selector switches, plus ALL CALL, Power ON/OFF.
POWER SUPPLY	AC 220-240V, 50/60Hz; DC 24V (2 × 12V Car Battery)
DIMENSIONS	W483 × H53 × D180 mm
WEIGHT	2.73kg



Hallmark of Reliability!



Mixers & Processors

Sophisticated & feature packed !

AHUJA mixers enable effortless management of multi-microphone installations under the most demanding of conditions.

AHUJA provides a wide range of mixers - ranging from small, portable units for field use, to large table top models designed for very large music programmes.

Applications

Concerts | Auditoriums | Live Shows | DJs

PROMIX-1442R AC Operation

With Built-in MP3 Recorder, 24 Digital Effects, 2 Group Outputs, 48V Phantom Supply on all Channels



14 CHANNEL

- Professional mixer with user-friendly construction & aesthetically designed side panels.
- 12 MIC and 10 LINE Balanced Mono inputs with enhanced headroom. 2 STEREO Balanced inputs.
- Built-in MP3 recorder with USB playback and Bluetooth facility.
- Digital multi EFFECTS processor with 24 built-in effects.
- LCD display for viewing the EFFECTS/USB settings.
- All MIC inputs are through 3 pin F/XLR connectors.
- All LINE & STEREO inputs are through 6.3 mm (1/4") stereo phone jack sockets.
- All MIC inputs are available with 48V phantom supply which can be switched ON/OFF.
- Each input channel has a GAIN control, 4 band active EQ controls, AUX1, AUX2, AUX3/EFX, AUX4/FX and PAN control.
- The STEREO channel has a GAIN control, 3 band active EQ control, AUX1, AUX2, AUX3/EFX, AUX4/FX and PAN control.
- PRE/POST selector switch for AUX1 and AUX2 in each channel.
- Channel MUTE switch provided on each individual channel.
- Peak LED for signal clipping indication. Signal LED for input signal indication.
- Balanced Left & Right MAIN Mix outputs through M/XLR connectors as well as 6.3 mm (1/4") stereo phone jack sockets.
- Stereo Tape Playback Input through L&R RCA sockets.
- Stereo Tape Output through L&R RCA sockets.
- Two GROUP outputs through 6.3 mm (1/4") phone jack sockets and individual group faders.
- Monitor outputs through 6.3 mm (1/4") phone jack sockets and individual control.
- Easy and accurate monitoring of Left & Right output levels through individual 12 segment LED array.
- L&R AUX RETURN inputs with level control. PFL switch on each channel.
- Headphone output with Level Control for output monitoring.
- Operates on 240V 50Hz AC mains.

SPECIFICATIONS

PROMIX-1442R

MIC INPUT Impedance/Gain	: 2k Ω Balanced/65dB
LINE INPUT Impedance/Gain	: 20k Ω Balanced/45dB
STEREO INPUT (L/Mono & R)	
Impedance/Gain	: 10k Ω Balanced/20dB
THD	: <0.08%
FREQUENCY RESPONSE	: 25Hz - 20kHz (+0, -1dB)
EQUALIZATION	
HI/Hi-Mid/LOW-Mid/LOW	: \pm 12dB at 12kHz/2.5kHz/400Hz/80Hz
CLIP LED INDICATION	: 4 dB prior to true clip
LINE OUTPUT Nominal/Max Level	: 4dBu/21dBu (1.22V/9V)
IMPEDANCE	: 600 Ω
DIGITAL EFFECTS	: 24 Effects Digital Processor
DIGITAL PLAYER	: MP3 Player with Recording & BT functions
HEADPHONE OUTPUT	: 200mV at 8 Ω , THD <1%

MAXIMUM GAIN	
Mic Input to Line Outputs	: 90dB
Line Input to Line Outputs	: 70dB
Stereo Input to Line Outputs	: 20dB
AUX Send (Pre) Unbalanced	: 5V
AUX Send (Post) Unbalanced	: 9V
AUX Return (L&R) Balanced	: 600mV
GROUP OUTPUTS	: 3V
MONITOR OUTPUTS	: 1V
Tape Output (L&R)	: 775mV
Tape Input (L&R)	: 100mV
SIGNAL TO NOISE RATIO	: >80dB
POWER SUPPLY	: AC: 220-240V, 50/60Hz
DIMENSIONS	: W560 \times H111 \times D410 mm
WEIGHT	: 6.70kg

PMX-1632FX AC Operation
 With Digital Effects, 48V Phantom Supply on 4 Channels



16 CHANNEL

- Rugged, stable, high quality analog mixers with user-friendly construction & aesthetically designed side panels.
- 12 MIC/LINE Balanced Mono input channels and 2 STEREO Balanced input channels.
- MIC/LINE Balanced Mono inputs with enhanced headroom.
- All MIC inputs are through 3 pin F/XLR connectors and all LINE & STEREO inputs are through 6.3 mm (1/4") stereo phone jack sockets.
- Four MIC inputs (MIC-1 to MIC-4) are available with 48V phantom supply which can be switched ON/OFF through a common switch.
- STEREO Balanced input in two selectable sensitivities of -10dBu & +4dBu.
- Separate EFFECT channel is provided for operating the built-in digital effect processor through a delay selector switch, delay, repeat and level controls.
- Each MIC/LINE channel has a GAIN control, 3 band active Equalizer controls, a Pre-fader AUX1 control, a Post-fader AUX2 /EFX control & a PAN control.
- Each STEREO channel has a GAIN control, 2 band active Equalizer controls, AUX1 Pre fader control, AUX2/EFX Post fader control and a BALANCE control.
- Channel ON/OFF switch provided on each individual channel. Peak LED for signal clipping indication.
- High precision 60 mm slide fader on each channel.
- Balanced Left & Right Line outputs through M/XLR connectors as well as 6.3 mm (1/4") stereo phone jack sockets.
- Easy and accurate monitoring of Left & Right output levels through individual 12 segment LED array.
- Two AUX SEND outputs with level controls: one each for monitoring and effects processing applications.
- Two stereo AUX RETURN balanced inputs with level controls.
- Headphone output with Level Control for output monitoring.
- Stereo RCA IN/OUT for record and playback.
- Operates on 240V 50Hz AC mains.

SPECIFICATIONS		PMX-1632FX	
MIC INPUT		DELAY RANGE SETTINGS	: 1: 60-300ms, 2: 300-500ms, 3: 500-650ms
Impedance/Gain	: 2kΩ Balanced/65dB	HEADPHONE OUTPUT	: 200mV at 8Ω, THD <1%
LINE INPUT		MAXIMUM GAIN	
Impedance/Gain	: 20kΩ Balanced/45dB	Mic Input to Line Outputs	: 78dB
STEREO INPUT (L/Mono & R)		Line Input to Line Outputs	: 58dB
Impedance/Gain (-10dBu Input)	: 10kΩ Balanced/14dB	Stereo Input to Line Outputs	: 28dB (-10dBu Input)
Impedance/Gain (+4dBu Input)	: 10kΩ Balanced/0dB		14dB (+4dBu Input)
THD	: <0.08%	AUX Send (Pre)	: 1.4V/100Ω Unbalanced
FREQUENCY RESPONSE	: 25Hz - 20kHz (+0, -1dB)	AUX Send (Post)	: 2.7V/100Ω Unbalanced
EQUALIZATION		AUX Return (L&R)	: 150mV/10kΩ Balanced
Bass/Mid/Treble	: ±12dB at 100Hz/2kHz/10kHz	Record Output (L&R)	: 250mV/600Ω
CLIP LED INDICATION	: 4 dB prior to true clip	Playback Input (L&R)	: 250mV/1kΩ (variable through GAIN control)
LINE OUTPUT		SIGNAL TO NOISE RATIO	: >70dB
Nominal/Max Level	: 4dBu/21dBu (1.22V/9V)	POWER SUPPLY	: AC: 220-240V, 50/60Hz
IMPEDANCE	: 600Ω	DIMENSIONS	: W609 × H110 × D435 mm
DELAY SYSTEM	: Digital Signal Processing	WEIGHT	: 9.80kg



PMX-1032DFX AC Operation

With Built-in MP3 Player, Digital Effects, 48V Phantom Supply on 4 Channels



10 CHANNEL

- Rugged, stable, high quality analog mixers with user-friendly construction & aesthetically designed side panels.
- 8 MIC/LINE Balanced Mono input channels and 1 STEREO Balanced input channel.
- Digital MP3 Player with USB, SD card reader and Bluetooth facility.
- MIC/LINE Balanced Mono inputs with enhanced headroom.
- All MIC inputs are through 3 pin F/XLR connectors and all LINE & STEREO inputs are through 6.3 mm (1/4") stereo phone jack sockets.
- Four MIC inputs (MIC-1 to MIC-4) are available with 48V phantom supply which can be switched ON/OFF through a common switch.
- STEREO Balanced input in two selectable sensitivities of -10dBu & +4dBu.
- Separate EFFECT channel is provided for operating the built-in digital effect processor through delay, repeat and level controls.
- Each MIC/LINE channel has a GAIN control, 3 band active Equalizer controls, a Pre-fader AUX1 control, a Post-fader AUX2 /EFX control & a PAN control.
- Each STEREO channel has a GAIN control, 2 band active Equalizer controls, AUX1 Pre fader control, AUX2/EFX Post fader control and a BALANCE control.
- Channel ON/OFF switch provided on each individual channel. Peak LED for signal clipping indication.
- High precision 60 mm slide fader on each channel.
- Balanced Left & Right Line outputs through M/XLR connectors as well as 6.3 mm (1/4") stereo phone jack sockets.
- Easy and accurate monitoring of Left & Right output levels through individual 12 segment LED array.
- Two AUX SEND outputs with level controls: one each for monitoring and effects processing applications.
- Two stereo AUX RETURN balanced inputs with level controls.
- Headphone output with Level Control for output monitoring.
- Stereo RCA IN/OUT for record and playback.
- Operates on 240V 50Hz AC mains.

SPECIFICATIONS

PMX-1032DFX

MIC INPUT Impedance/Gain	: 2k Ω Balanced/65dB	HEADPHONE OUTPUT	: 200mV at 8 Ω , THD <1%
LINE INPUT Impedance/Gain	: 20k Ω Balanced/45dB	MAXIMUM GAIN	
STEREO INPUT (L/Mono & R)		Mic Input to Line Outputs	: 78dB
Impedance/Gain (-10dBu Input)	: 10k Ω Balanced/14dB	Line Input to Line Outputs	: 58dB
Impedance/Gain (+4dBu Input)	: 10k Ω Balanced/0dB	Stereo Input to Line Outputs	: 28dB (-10dBu Input) 14dB (+4dBu Input)
THD	: <0.08%	AUX Send (Pre)	: 1.4V/100 Ω Unbalanced
FREQUENCY RESPONSE	: 25Hz - 20kHz (+0, -1dB)	AUX Send (Post)	: 2.7V/100 Ω Unbalanced
EQUALIZATION Bass/Mid/Treble	: \pm 12dB at 100Hz/2kHz/10kHz	AUX Return (L&R)	: 150mV/10k Ω Balanced
CLIP LED INDICATION	: 4 dB prior to true clip	Record Output (L&R)	: 250mV/600 Ω
LINE OUTPUT Nominal/Max Level	: 4dBu/21dBu (1.22V/9V)	Playback Input (L&R)	: 250mV/1k Ω (variable through GAIN control)
IMPEDANCE	: 600 Ω	SIGNAL TO NOISE RATIO	: >70dB
DELAY SYSTEM	: Digital Signal Processing	POWER SUPPLY	: AC: 220-240V, 50/60Hz
DELAY RANGE SETTINGS	: Variable from 30 to 400ms	DIMENSIONS	: W465 \times H110 \times D435 mm
DIGITAL PLAYER	: MP3 Player with USB, SD and MMC Card Reader	WEIGHT	: 7.70kg



14 CHANNEL

AMX-1412 AC & 24V DC Operation With built-in Digital Effects

- Each Channel has separate 6.3 mm (1/4") balanced phone jack for balanced & unbalanced Mic and Line input signals.
- AUX Send & AUX Return are provided for sending the pre-fader output of channels for monitoring or for adding a Special Effects Unit.
- Mono output is available from Left & Right output jacks when the switch is in 'Mono' position.
- Each channel has GAIN, BASS, MID, TREBLE, ECHO, PAN and slide LEVEL controls with CLIP LED indicator.
- Echo section provided with Delay, Repeat & Level controls.
- Stereo RCA IN/OUT for record and playback.
- Headphone output with volume control is provided.



9 CHANNEL

AMX-912DP AC & 24V DC Operation With built-in MP3 Player & Digital Effects

- Each Channel has separate 6.3 mm (1/4") balanced phone jack for balanced & unbalanced Mic and Line input signals.
- Built-in MP3 Player, with Bluetooth facility, is selectable through Channel 9/USB Switch and controllable through an independent USB input volume control. Channel 9 can be used for Mic & Line inputs or USB Playback function.
- Mono output is available from Left & Right output jacks when the switch is in 'Mono' position.
- Each channel has GAIN, BASS, TREBLE, ECHO, PAN and slide LEVEL controls with CLIP LED indicator.
- Echo section provided with Delay, Repeat & Level controls.
- Stereo RCA IN/OUT for record and playback.
- Headphone output with volume control is provided.



9 CHANNEL

AMX-912 AC & 24V DC Operation With built-in Digital Effects

- Each Channel has separate 6.3 mm (1/4") balanced phone jack for balanced & unbalanced Mic and Line input signals.
- Mono output is available from Left & Right output jacks when the switch is in 'Mono' position.
- Each channel has GAIN, BASS, TREBLE, ECHO, PAN and slide LEVEL controls with CLIP LED indicator.
- Echo section provided with Delay, Repeat & Level controls.
- Stereo RCA IN/OUT for record and playback.
- Headphone output with volume control is provided.

SPECIFICATIONS	AMX-1412	AMX-912DP	AMX-912
MIC INPUT (Impedance/Gain)	2kΩ Balanced/62dB, 1kΩ Unbalanced/62dB	2kΩ Balanced/62dB, 1kΩ Unbalanced/62dB	2kΩ Balanced/62dB, 1kΩ Unbalanced/62dB
LINE INPUT (Impedance/Gain)	20kΩ Balanced/42dB, 10kΩ Unbalanced/42dB	20kΩ Balanced/42dB, 10kΩ Unbalanced/42dB	20kΩ Balanced/42dB, 10kΩ Unbalanced/42dB
DISTORTION	< 0.08%	< 0.08%	< 0.08%
FREQUENCY RESPONSE	30Hz - 20kHz (+0, -1dB)	30Hz - 20kHz (+0, -1dB)	30Hz - 20kHz (+0, -1dB)
TONE CONTROLS	Bass : ±12dB at 100Hz, Mid : ±12dB at 2kHz, Treble : ±12dB at 10kHz	Bass : ±12dB at 100Hz, Treble : ±12dB at 10kHz	Bass : ±12dB at 100Hz, Treble : ±12dB at 10kHz
OUTPUT LINE OUTPUT LO	-10dBu/+2dBu (200mV/1V)	-10dBu/+2dBu (200mV/1V)	-10dBu/+2dBu (200mV/1V)
LINE OUTPUT HI	0dBu/+17dBu (775mV/5.5V)	0dBu/+17dBu (775mV/5.5V)	0dBu/+17dBu (775mV/5.5V)
DELAY RANGE SETTINGS	Variable from 20 to 600ms	Variable from 30 to 400ms	Variable from 30 to 400ms
DIGITAL PLAYER	—	With USB, SD, MMC Card & Bluetooth	—
SIGNAL TO NOISE RATIO	>70dB (0dBm, 0.775V)	>70dB (0dBm, 0.775V)	>70dB (0dBm, 0.775V)
POWER SUPPLY	AC: 220-240V 50/60Hz, DC: 24V (2×12V Car Battery)	AC: 220-240V 50/60Hz, DC: 24V (2×12V Car Battery)	AC: 220-240V 50/60Hz, DC: 24V (2×12V Car Battery)
DIMENSIONS	W633 × H93 × D420 mm	W483 × H93 × D366 mm	W483 × H93 × D366 mm
WEIGHT	9.40kg	6.90kg	6.90kg



FMX-212PRO AC Operation

With Built-in MP3 Recorder, 24 Digital Effects, 48V Phantom Supply on all Channels



12 CHANNEL

- Reliable and versatile professional Audio Mixer in a compact and aesthetically superior construction.
- 10 MIC and 10 LINE Balanced Mono inputs with enhanced headroom. One STEREO Balanced input.
- Built-in digital MP3 player with recording & BT functions.
- Digital multi EFFECTS processor with 24 built-in effects.
- LCD display for viewing the EFFECTS/USB settings.
- All MIC inputs are through 3 pin F/XLR connectors.
- All LINE & STEREO inputs are through 6.3 mm (1/4") stereo phone jack sockets.
- All MIC inputs are available with 48V phantom supply, with ON/OFF switch for every two MIC inputs.
- Each input channel has a GAIN control, 3 band active EQ controls, AUX, FX and PAN control.
- The STEREO channel has a GAIN control, 3 band active EQ control, AUX, FX and PAN control.
- Peak LED for signal clipping indication. PFL switch for each channel.
- Balanced Left & Right MAIN Mix outputs through M/XLR connectors as well as 6.3 mm (1/4") stereo phone jack sockets.
- Monitor L&R outputs through 6.3 mm (1/4") phone jack sockets and individual fader control.
- Easy and accurate monitoring of Left & Right output levels through individual 12 segment LED array.
- Headphone output with Phones Control for output monitoring.
- Operates on 240V 50Hz AC mains.

SPECIFICATIONS

FMX-212PRO

MIC INPUT	Impedance	: 600Ω		
Impedance/Gain	: 2kΩ Balanced/65dB	DIGITAL EFFECTS	: 24 Effects Digital Processor	
LINE INPUT	Impedance/Gain	: 20kΩ Balanced/45dB	DIGITAL PLAYER	: MP3 Player/Recorder with USB Reader, Bluetooth
STEREO INPUT (L/Mono & R)	Impedance/Gain	: 10kΩ Balanced/20dB	HEADPHONE OUTPUT	: 200mV at 8Ω, THD <1%
THD	: <0.08%	FREQUENCY RESPONSE	MAXIMUM GAIN	
L/R Line Output	: 25Hz - 20kHz (+0, -1dB)	EQUALIZATION	Mic Input to Line Outputs	: 90dB
TREBLE/MID/BASS	: ±12dB at 12kHz/2.5kHz/80Hz	CLIP LED INDICATION	Line Input to Line Outputs	: 70dB
CLIP LED INDICATION	: 4 dB prior to true clip	LINE OUTPUT	Stereo Input to Line Outputs	: 20dB
Nominal/Max Level	: 4dBu/21dBu (1.22V/9V)	LINE OUTPUT	AUX Send (Pre) Unbalanced	: 5V
		LINE OUTPUT	MONITOR OUTPUTS (L&R)	: 1.6V
		LINE OUTPUT	SIGNAL TO NOISE RATIO	: >80dB
		LINE OUTPUT	POWER SUPPLY	: AC: 220-240V, 50/60Hz
		LINE OUTPUT	DIMENSIONS	: W522 × H135 × D385mm
		LINE OUTPUT	WEIGHT	: 5.45kg



FMX-112DP AC Operation

With built-in MP3 Recorder & Digital Effects



12 CHANNEL

- Professional 12 channel mixer with user friendly features, in a compact & aesthetically superior construction.
- 10 MIC, 10 LINE & 01 STEREO Balanced inputs, through 6.3 mm (1/4") stereo phone jack socket.
- Built-in digital MP3 player with recording & BT functions.
- Digital Effects channel with DELAY, REPEAT & LEVEL controls.
- Each input channel has a GAIN control, 3 band active EQ controls, AUX, FX and PAN controls.
- The STEREO channel has a GAIN control, 3 band active EQ controls, AUX, FX and PAN controls.
- Each input channel provides Peak LED to indicate excessive input signal levels.
- Each channel has a signal Mute switch and a slide fader control for accurate setting of signal level.
- Selector switch available between Stereo channel (Ch.11/12) & USB playback channel.
- Balanced Left & Right MAIN Mix outputs through M/XLR connectors as well as 6.3 mm (1/4") stereo phone jack sockets.
- MONITOR L&R outputs through 6.3 mm (1/4") phone jack sockets and individual monitor fader control.
- AUX SEND output with independent level control.
- Headphone output with Phones Control for output monitoring.
- Operates on 240V 50Hz AC mains.

SPECIFICATIONS		FMX-112DP	
MIC INPUT		LINE OUTPUT	
Impedance/Gain	: 2k Ω Balanced/65dB	Nominal/Max Level	: 4dBu/21dBu (1.22V/9V)
LINE INPUT		Impedance	: 600 Ω
Impedance/Gain	: 20k Ω Balanced/45dB	DELAY SYSTEM	: Digital Signal Processing
STEREO INPUT (L/Mono & R)		DELAY RANGE SETTINGS	: Variable from 20 to 300ms
Impedance/Gain	: 10k Ω Balanced/20dB	DIGITAL PLAYER	: MP3 Player/Recorder with USB Reader, Bluetooth
THD	: <0.1%	HEADPHONE OUTPUT	: 200mV at 8 Ω , THD <1%
FREQUENCY RESPONSE		MONITOR OUTPUTS (L&R)	: 1.6V
L/R Line Output	: 25Hz - 20kHz (+0, -1dB)	SIGNAL TO NOISE RATIO	: >80dB
EQUALIZATION		POWER SUPPLY	: AC: 220-240V, 50/60Hz
TREBLE/MID/BASS	: \pm 12dB at 12kHz/2.5kHz/80Hz	DIMENSIONS	: W520 \times H105 \times D350mm
CLIP LED INDICATION	: 4 dB prior to true clip	WEIGHT	: 5.20kg



FMX-108DP AC Operation

With built-in MP3 Recorder & Digital Effects



8 CHANNEL

- Compact and reliable professional PA Mixer which is aesthetically superior and easily portable.
- Provided with two balanced XLR microphone inputs, with switchable +48V Phantom supply.
- Additionally, four low impedance microphones can be connected in either balanced or unbalanced configuration, through a 6.3 mm (1/4") stereo jack socket.
- Upto six line level signal sources can be connected in either balanced or unbalanced configuration, through a 6.3 mm (1/4") stereo jack socket.
- Each channel has a GAIN control for optimum adjustment of the MIC & LINE input sensitivities.
- Two band equalizer with active BASS & TREBLE controls in each channel for desired equalisation of the input signal.
- Separate FX (effects) level control for each input channel.
- MP3 digital player with recording and playback through USB. Bluetooth facility also available.
- One independent stereo input channel is provided with a GAIN control, 2 band EQ, FX & LEVEL Controls.
- Each channel has a PEAK LED which glows when the level of input signal is excessive.
- A push switch is provided for selection between Ch 7/8 and USB channel.
- Built-in digital effects processor with DELAY, REPEAT and LEVEL controls.
- Effects ON/OFF switch with FX ON & PEAK LEDs.
- Line level LEFT & RIGHT outputs through 6.3 mm (1/4") stereo jack sockets.
- Headphone output, with independent volume control, is available through a 6.3 mm (1/4") stereo jack socket.
- Individual SIGNAL & CLIP LEDs for optimum setting of Left & Right output levels.
- Individual MASTER volume controls for Left & Right line outputs.
- Operates on 240V, 50Hz AC Mains.

SPECIFICATIONS	FMX-108DP
MIC INPUT (IMPEDANCE/GAIN)	2k Ω Balanced/65dB, 1k Ω Unbalanced/65dB
LINE INPUT (IMPEDANCE/GAIN)	20k Ω Balanced/45dB, 10k Ω Unbalanced/45dB
DISTORTION	< 0.1%
FREQUENCY RESPONSE	25-20,000Hz (-1dB)
TONE CONTROLS	Bass: \pm 15dB at 80Hz, Treble: \pm 15dB at 12kHz
LINE OUTPUT	0dBu/+21dBu (775mV/9V)
DELAY SYSTEM	Digital Signal Processing
DELAY RANGE SETTINGS	Variable from 20 to 300ms
DIGITAL PLAYER	MP3 Player/Recorder with USB Reader, Bluetooth
SIGNAL TO NOISE RATIO	> 68dB
POWER SUPPLY	AC: 220-240V 50/60Hz
DIMENSIONS	W345 \times H75 \times D210mm
WEIGHT	1.85kg



6 CHANNEL

FMX-106[®]DP AC Operation With built-in MP3 Recorder & Digital Effects

- Compact and reliable professional PA Mixer which is aesthetically superior and easily portable.
- Upto four low impedance microphones and Line level signal sources can be connected in either balanced or unbalanced configuration, through a 6.3 mm (1/4") stereo jack socket.
- Each channel has a GAIN control for optimum adjustment of the MIC & LINE input sensitivities.
- Active BASS & TREBLE controls in each channel for desired equalisation of the input signal.
- Separate FX (effects) level control for each input channel.
- MP3 digital player with recording, playback through USB & Bluetooth facility.
- Stereo input channel is provided with a GAIN control, 2 band EQ, FX & LEVEL Controls.
- Built-in digital effects processor with DELAY, REPEAT and LEVEL controls.
- Line level LEFT & RIGHT outputs through 6.3 mm (1/4") stereo jack sockets. Individual SIGNAL & CLIP LEDs for optimum setting of signal levels.



6 CHANNEL

FMX-106[®] AC Operation With built-in Digital Effects

- Compact and reliable professional PA Mixer which is aesthetically superior and easily portable.
- Upto four low impedance microphones and Line level signal sources can be connected in either balanced or unbalanced configuration, through a 6.3 mm (1/4") stereo jack socket.
- Each channel has a GAIN control for optimum adjustment of the MIC & LINE input sensitivities.
- Active BASS & TREBLE controls in each channel for desired equalisation of the input signal.
- Separate FX (effects) level control for each input channel.
- Stereo input channel is provided with a GAIN control, 2 band EQ, FX & LEVEL Controls.
- Built-in digital effects processor with DELAY, REPEAT and LEVEL controls.
- Line level LEFT & RIGHT outputs through 6.3 mm (1/4") stereo jack sockets. Individual SIGNAL & CLIP LEDs for optimum setting of signal levels.

SPECIFICATIONS	FMX-106 [®] DP	FMX-106 [®]
MIC INPUT (IMPEDANCE/GAIN)	2k Ω Balanced/65dB, 1k Ω Unbalanced/65dB	2k Ω Balanced/65dB, 1k Ω Unbalanced/65dB
LINE INPUT (IMPEDANCE/GAIN)	20k Ω Balanced/45dB, 10k Ω Unbalanced/45dB	20k Ω Balanced/45dB, 10k Ω Unbalanced/45dB
DISTORTION	< 0.1%	< 0.1%
FREQUENCY RESPONSE	25Hz-20 kHz (-1dB)	25Hz-20 kHz (-1dB)
TONE CONTROLS	Bass: ± 15 dB at 80Hz, Treble: ± 15 dB at 12kHz	Bass: ± 15 dB at 80Hz, Treble: ± 15 dB at 12kHz
LINE OUTPUT	0dBu / +21dBu (775mV/9V)	0dBu / +21dBu (775mV/9V)
DELAY SYSTEM	Digital Signal Processing	Digital Signal Processing
DELAY RANGE SETTINGS	Variable from 20 to 300ms	Variable from 20 to 300ms
DIGITAL PLAYER	MP3 Player/Recorder with USB Reader, Bluetooth	—
SIGNAL TO NOISE RATIO	> 68dB	> 68dB
POWER SUPPLY	AC: 220-240V 50/60Hz	AC: 220-240V 50/60Hz
DIMENSIONS	W281 \times H75 \times D210 mm	W281 \times H75 \times D210 mm
WEIGHT	1.60kg	1.60kg





MMX-55 AC & 12V DC Operation

Compact General Purpose 5 Channel PA Mixer Preamplifier

- 5 Mic/Aux inputs with individual volume controls.
- Selectable HI/LO sensitivity for AUX inputs.
- Compact and easy to use.
- Peak LED for setting distortion-free input levels.

MX-15 AC & 12V DC Operation

General Purpose 12 Channel PA Mixer Preamplifier

- 9 Mic inputs; each with an On/Off switch and LED indicator. 3 Mic/Aux inputs.
- Master control for overall adjustment.
- 4 Line outputs for connecting a number of Amplifiers or Boosters. Headphone output for monitoring.
- Active Bass and Treble tone controls.

SPECIFICATIONS	MMX-55	MX-15
OUTPUTS	1 × Preamp 200mV/600Ω	2 × Preamp 200mV/600Ω, 4 × Line 1V/1kΩ, 1 × Headphone 120mV@ 8Ω
FREQUENCY RESPONSE	20-20,000Hz (±3dB)	20-20,000Hz (±3dB)
DISTORTION	< 1%	< 1%
SIGNAL TO NOISE RATIO	40dB	50dB
INPUT CHANNELS	5 × Mic 0.6mV/4.7kΩ, 5 × Aux LO 50mV/470kΩ; Aux HI 150mV/470kΩ (Mic/Aux LO/ Aux HI switchable)	12 × Mic 0.6mV/4.7kΩ, 2 × Aux 100mV/470kΩ, 1 × Aux 500mV/100kΩ
TONE CONTROLS	—	Bass: ± 10dB at 100Hz, Treble: ± 10dB at 10kHz
POWER SUPPLY	AC: 220-240V 50/60Hz, DC: 12V (1 × 12V Car Battery)	AC: 220-240V 50/60Hz, DC: 12V (1 × 12V Car Battery)
DIMENSIONS	W215 × H60 × D125 mm	W355 × H145 × D215 mm
WEIGHT	1.20kg	3.70kg

Audio Effect Processors



DMX-44 AC & 12V DC Operation

Professional 4 Channel Mixer Preamplifier with Digital Effects Processor for Echo, Reverb, Chorus Effect

- 3 Selectable delay settings for fine adjustment.
- Compatible with Audio Mixing Consoles.
- Peak LED for setting optimum distortion free input levels.
- Echo facility on all inputs through Echo level, repeat & delay controls.

DMX-22 AC & 12V DC Operation

2 Channel Mixer Preamplifier for Echo, Reverb, Chorus, Effects

- Digital Signal Processing.
- Adds colour to vocal & musical instruments.
- Peak LED for setting optimum distortion free input levels.
- Echo facility on all inputs through Echo volume, repeat & delay controls.

SPECIFICATIONS	DMX-44	DMX-22
OUTPUTS	Preamp: 200mV/680Ω, Line: 775mV/1kΩ	Preamp: 200mV
FREQUENCY RESPONSE	20-20,000Hz (±1dB)	20-20,000Hz (±3dB)
DISTORTION	< 1%	< 1%
SIGNAL TO NOISE RATIO	45dB	40dB
INPUT CHANNELS	4 × Mic 2.5mV/10kΩ, 1 × Aux 250mV/220kΩ	2 × Mic 0.6mV
ECHO REVERB SYSTEM	Digital Signal Processing	Digital Signal Processing
DELAY TIME RANGE	60ms to 300ms, 300ms to 500ms, 500ms to 650ms	20ms to 600ms
POWER SUPPLY	AC: 220-240V 50/60Hz DC: 12V	AC: 220-240V 50/60Hz DC: 12V (1 × 12V Car Battery)
DIMENSIONS	W483 × H53 × D197 mm	W215 × H60 × D125 mm
WEIGHT	2.50kg	1.20kg

85
YEARS+
SINCE 1940

Hallmark of Reliability!



Microphones

Microphones are the first and most visible part in most public address systems. Outstanding sound reproduction requires outstanding microphones.

AHUJA offers a wide range of microphones: dynamic and condenser, handheld and lavalier, cabled and wireless.... an outstanding microphone for each & every application.

Applications

Public Meetings | Interviews | Recordings | Presentations | Car Paging

Celebrations | Mobile Announcements | Tourist Coaches | Places of Worship



PRO+ 7500du

LIVE STAGE PERFORMANCE MICROPHONE

PRO+ 7500du is a most elegant and durable Live Stage Performance Microphone with TWO CARTRIDGES for good distance pick-up. High sensitivity and supercardioid pattern makes it ideal for Live Stage Performances, as well as Vocal and Choir applications.

- Built-in dual high sensitivity cartridges for excellent distance pick-up.
- Cartridges are effectively shock mounted to reduce handling noises.
- Slide potentiometer for smooth and noiseless ON/OFF operation.
- Supercardioid polar pattern for obtaining higher gain before feedback.
- Unique hinge design for angle adjustment - forward 30° and backward 45°.
- Rugged zinc die-cast body in classic design.

Mic Type	: Dynamic
Polar Pattern	: Supercardioid
Impedance	: 1.2kΩ
Frequency Response	: 50-15,000Hz
Sensitivity	: 5.0mV/Pa
Switch	: ON/OFF Slide Potentiometer Switch

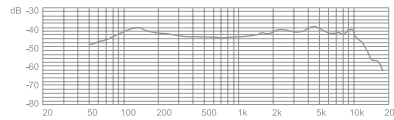

Frequency Response Curve

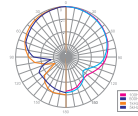

Polar Pattern

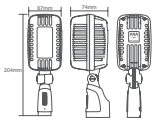

Dimensions

PROFESSIONAL PERFORMANCE SERIES

Supercardioid Dynamic Pro-Entertainment + Studio



PRO+ 3400

Premium microphone for the most demanding high end applications. Superb shock mount system of the cartridge. Noiseless magnetic reed switch. Ideal for all Vocal and PA applications.

- Frequency Response : 40-16,000Hz
- Sensitivity : 3.15mV/Pa
- Impedance : 350Ω

Supplied with quick detachable microphone holder with 3-pin professional XLR connector & 10m twin core shielded low noise cable.

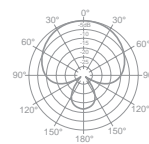
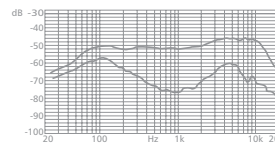

Supercardioid Dynamic Pro-Entertainment + Studio



PRO+ 3200

Professional microphone for live vocal, music instruments, studio recording & broadcasting. Superior double shock-mount system and noiseless switch. Exceptionally warm and articulate sound.

- Frequency Response : 50-18,000Hz
- Sensitivity : 2.5mV/Pa
- Impedance : 300Ω

Supplied with quick detachable microphone holder with 3-pin professional XLR connector & 10m twin core shielded low noise cable.

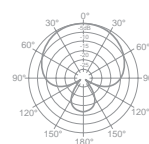
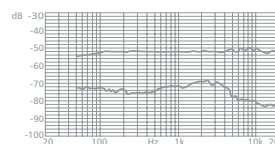

Supercardioid Dynamic Pro-Entertainment



PRO-2200SC

Great performance microphone for live vocal & music. Hardened grille with anti-roll rubber ring.

- Frequency Response : 50-18,000Hz
- Sensitivity : 2.1mV/Pa
- Impedance : 300Ω

Supplied with quick detachable microphone holder with 3-pin professional XLR connector & 10m twin core shielded low noise cable.

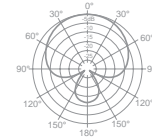
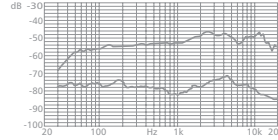

Supercardioid Dynamic Vocal & Speech



DM+2100

Professional performance microphone for various high end applications. Attractive and rugged microphone with shock mount system. Intelligent and crisp sound reproduction. Wide frequency response to cover all speech and music applications. Ideal for all Vocal and PA applications.

- Frequency Response : 40-16,000Hz
- Sensitivity : 3.15mV/Pa
- Impedance : 350Ω

Supplied with quick detachable microphone holder.

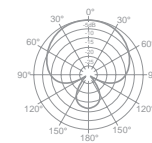
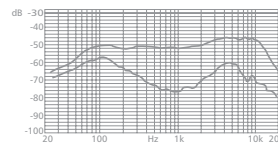

Supercardioid Dynamic Speech & Vocal



DM-740

Highly sensitive cartridge with most natural reproduction. Ideal for live vocal, music and PA applications.

- Frequency Response : 50-15,000Hz
- Sensitivity : 2.5mV/Pa
- Impedance : 600Ω

Supplied with quick detachable microphone holder.

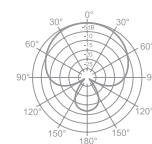
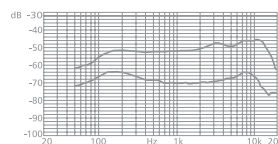

Unidirectional Dynamic Speech & Vocal



DM-440

Intelligible and crisp sound reproduction. Wide frequency response and cardioid pick-up pattern. Ideal for high end speech & music applications.

- Frequency Response : 50-15,000Hz
- Sensitivity : 2.0mV/Pa
- Impedance : 600Ω

Supplied with quick detachable microphone holder.

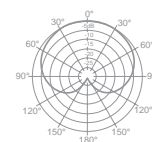
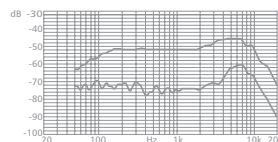

Unidirectional Dynamic Music & Vocal



ASM-780XLR

High output neodymium cartridge, excellent intelligibility & wide frequency response. Ideal for live vocal, music & studio applications.

- Frequency Response : 50-16,000Hz
- Sensitivity : 2.0mV/Pa
- Impedance : 300Ω

Supplied with quick detachable microphone holder with 3-pin professional XLR connector & 10m twin core shielded low noise cable.

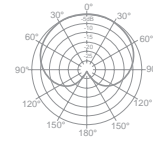
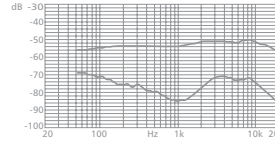

Unidirectional Dynamic Speech & Vocal



ASM-580XLR®

Upper mid-range presence peak for intelligible sound and ideal for close-to-lip singing. Accentuates warmth and clarity.

- Frequency Response : 50-16,000Hz
- Sensitivity : 2.0mV/Pa
- Impedance : 300Ω

Supplied with quick detachable microphone holder with 3-pin professional XLR connector & 10m twin core shielded low noise cable.

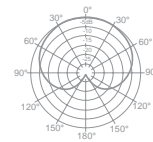
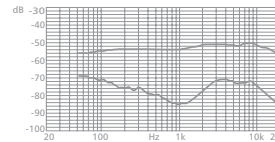

GENERAL PA SERIES

Supercardioid Dynamic Multi Purpose Applications



AUD-101MXLR

All purpose microphone reproducing intelligible, crisp and a bright sound. Suitable for live vocal and multi-purpose PA applications.

- Frequency Response : 50-15,000Hz
- Sensitivity : 2.5mV/Pa
- Impedance : 600Ω

Supplied with quick detachable microphone holder with 3-pin professional XLR connector & 6m twin core shielded low noise cable.

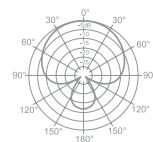
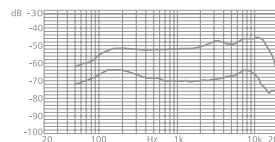

Unidirectional Dynamic Multi Purpose Applications



AUD-100XLR

High Output Neodymium cartridge. Rugged and reliable PA microphone with non-reflective finish. Ideal for amateur artistes on stage. Recommended for speech and paging applications.

- Frequency Response : 50-15,000Hz
- Sensitivity : 2.5mV/Pa
- Impedance : 600Ω

Supplied with quick detachable microphone holder with 3-pin professional XLR connector & 6m twin core shielded low noise cable.

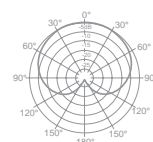
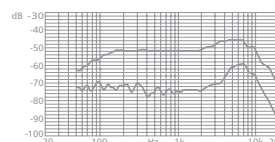

Unidirectional Dynamic Multi Purpose Applications



AUD-99XLR®

For general PA applications, a robust and reliable microphone. Ideal for addressing an audience.

- Frequency Response : 50-15,000Hz
- Sensitivity : 2.5mV/Pa
- Impedance : 600Ω

Supplied with quick detachable microphone holder with 3-pin professional XLR connector & 6m twin core shielded low noise cable.

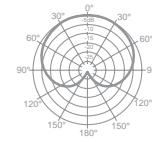
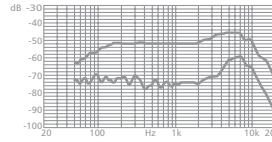

Unidirectional Dynamic PA Applications



AUD-98XLR®

High output Neodymium cartridge. Excellent intelligibility & wide frequency response. Attractive appearance.

- Frequency Response : 50-15,000Hz
- Sensitivity : 2.5mV/Pa
- Impedance : 600Ω

Supplied with quick detachable microphone holder with 3-pin professional XLR connector & 6m twin core shielded low noise cable.

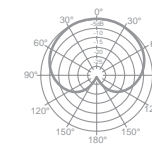
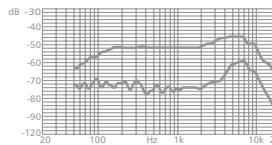

Unidirectional Dynamic PA Applications



AUD-97XLR®

Attractive appearance. Neodymium cartridge. High intelligibility & wide frequency response.

- Frequency Response : 50-15,000Hz
- Sensitivity : 2.5mV/Pa
- Impedance : 600Ω

Supplied with quick detachable microphone holder with 3-pin professional XLR connector & 6m twin core shielded low noise cable.

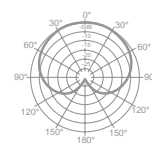
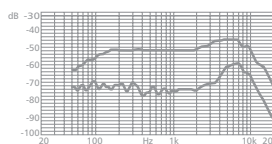

PROFESSIONAL ECONOMY SERIES

Unidirectional Dynamic Music & Vocal



ADM-511

Intelligible, crisp and bright sound suitable for all type of PA applications.

- Frequency Response : 50-15,000Hz
- Sensitivity : 2.0mV/Pa
- Impedance : 600Ω

Supplied with quick detachable microphone holder with 3-pin professional XLR connector & 6m twin core shielded low noise cable.

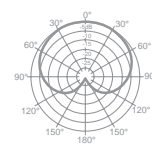
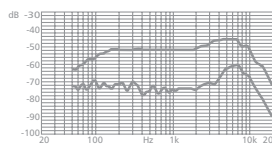

Microphones

Supercardioid Dynamic Music & Vocal



ADM-411

Neodymium cartridge. High intelligibility. Supercardioid polar pattern provides maximum isolation from nearby vocalists.

- Frequency Response : 50-15,000Hz
- Sensitivity : 2.5mV/Pa
- Impedance : 600Ω

Supplied with quick detachable microphone holder with 3-pin professional XLR connector & 6m twin core shielded low noise cable.

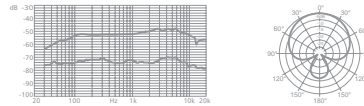

Unidirectional Dynamic Multi Purpose Applications



ADM-311

High output Neodymium cartridge, excellent intelligibility & wide frequency response for clean sound reproduction.

- Frequency Response : 50-15,000Hz
- Sensitivity : 2.5mV/Pa
- Impedance : 600Ω

Supplied with quick detachable microphone holder with 3-pin professional XLR connector & 6m twin core shielded low noise cable.

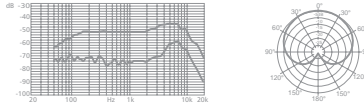

GENERAL PA ECONOMY SERIES WITH BUILT-IN MIC HOLDER

Unidirectional Dynamic All Purpose PA



AUD-77DX

Legendary multi-purpose microphone for general purpose PA applications like speech and music.

- Frequency Response : 50-15,000Hz
- Sensitivity : 2.5mV/Pa
- Impedance : 600Ω

Sturdy metal holder with 3-pin professional XLR connector & 6m shielded low noise cable.

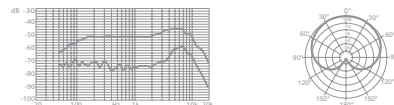

Unidirectional Dynamic All Purpose PA



AUD-70XLR

Robust and reliable microphone with non-reflective finish. Ideal for PA applications like speech/paging.

- Frequency Response : 50-15,000Hz
- Sensitivity : 2.5mV/Pa
- Impedance : 600Ω

Sturdy metal holder with 3-pin professional XLR connector & 5m shielded low noise cable.



Unidirectional Dynamic All Purpose PA



AUD-65XLR

An economy model microphone for PA speech applications.

- Frequency Response : 100-10,000Hz
- Sensitivity : 2.0mV/Pa
- Impedance : 600Ω

Sturdy metal holder with 3-pin professional XLR connector & 5m shielded low noise cable.

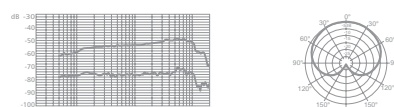

GENERAL PA ENTRY LEVEL ECONOMY SERIES

Unidirectional Dynamic



AUD-59XLR®

Attractive appearance, low cost PA microphone.

- Frequency Response : 100-10,000Hz
- Sensitivity : 2.5mV/Pa
- Impedance : 600Ω

Supplied with 4.5m shielded cable terminated with 3-pin XLR connector and quick detachable microphone holder.

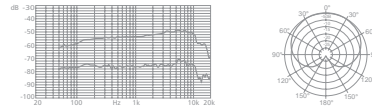

Unidirectional Dynamic



AUD-57XLR

Stylish economy microphone for various PA applications.

- Frequency Response : 50-15,000Hz
- Sensitivity : 2.1mV/Pa
- Impedance : 600Ω

Supplied with 4m shielded cable terminated with 3-pin XLR connector and quick detachable microphone holder.

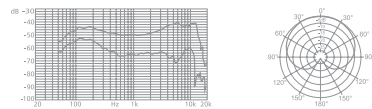

Unidirectional Dynamic



AUD-54

A basic economy microphone for Karaoke and PA applications.

- Frequency Response : 100-10,000Hz
- Sensitivity : 2.0mV/Pa
- Impedance : 600Ω

Supplied with 3m dedicated shielded cable with Ø6.3 mm (1/4") phone plug.

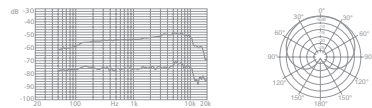

WIDE ANGLE LARGE DISTANCE PICK-UP

Unidirectional Stage & Studio



CSM-990

Excellent for interviews, musical instruments, stage, vocal and studio recording applications.

- Frequency Response : 100-15,000Hz
- Sensitivity (switchable) : 7.0mV/Pa, 3.5mV/Pa
- Impedance : 1000Ω
- Operates on : 1 × 1.5V (UM-3) Pencil Cell

Supplied with quick detachable microphone holder, 10m twin core shielded low noise cable & 3-pin XLR connector.

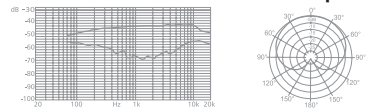

Supercardioid Dynamic Music & Vocal

Pack of Three ADM-411



TRINITY-411

Neodymium cartridge. High intelligibility. Supercardioid polar pattern provides maximum isolation from nearby vocalists.

- Frequency Response : 50-15,000Hz
- Sensitivity : 2.5mV/Pa
- Impedance : 600Ω

Supplied with three quick detachable microphone holders in an attractive plastic carry case.



Microphones

TIE-CLIP SERIES

Omnidirectional Condenser



CTP-10DX

Miniature omnidirectional electret condenser lavalier type microphone with wide angle pick-up for lectures, interviews, religious places, recordings etc. A strong, fixed tie-clip prevents the microphone from being displaced accidentally. The cell container is provided to accommodate a single pencil cell. The cable length is 6m.

- Frequency Response : 100-15,000Hz
- Sensitivity : 5.0mV/Pa
- Impedance : 1000 Ω
- Operates on : 1 \times 1.5V (UM-3) Pencil Cell

Unidirectional Condenser



UTP-30

Miniature unidirectional electret condenser lavalier type microphone for lectures, interviews, religious places, recordings etc. A strong, fixed tie-clip prevents the microphone from being displaced accidentally. Also a NECK-BAND is supplied if the tie-clip is not to be used. The cell container is provided to accommodate a single pencil cell. The cable length is 6m.

- Frequency Response : 100-15,000Hz
- Sensitivity : 7.0mV/Pa
- Impedance : 1000 Ω
- Operates on : 1 \times 1.5V (UM-3) Pencil Cell

Headband Microphones

Unidirectional Condenser



HBM-50

An elegant & reliable Headband Microphone. It can be worn around the head and the microphone positioned close to the lips. This allows the speaker to have his hands free and prevents background room noises from being freely picked up by the microphone.

- Ergonomic design for comfortable and convenient use.
- Allows hands-free use and reduces pickup of stray room noises.
- Suitable for various applications such as Announcements, Teaching, Presentations, Touring etc.
- Frequency Response : 50-16,000Hz
- Sensitivity : 5.6mV/Pa
- Impedance : 1000 Ω
- Cable Length : 1.25m
- Operates on : 1.5-9V DC

Unidirectional Condenser



HBM-60[®]CC

Condenser Headband Microphone supplied with 6m cable and a 1.5V cell container. Suitable for direct connection to an amplifier.

- Frequency Response : 50-16,000Hz
- Sensitivity : 5.6mV/Pa
- Impedance : 1000 Ω
- Cable Length : 6m
- Operates on : 1 \times 1.5V (UM-3) Pencil Cell

AWM-700®U2 Dual PA UHF Wireless Microphones



- Elegant & affordable high performance dual channel UHF wireless microphone available in different frequencies.
- Sturdy table-top dual channel receiver with frequency display.
- Separate volume control for both channels on the front panel of the receiver.
- Two handheld dynamic transmitters, each operating on 2 × 1.5V AA pencil cells.
- Separate balanced audio output from each channel through XLR connector and an unbalanced mixed output through 6.3 mm (1/4") jack socket available from the receiver.
- Receiver operates on 12V DC through an AC adaptor supplied along with the transmitter.
- Ideal for: PA Applications... Stage & Auditoriums... Stadia... Seminar Halls... Places of Worship... Recreation Centres...

SPECIFICATIONS	TRANSMITTER
RF OUTPUT POWER	10mW (Max.)
FREQUENCY STABILITY	±0.005%
MODULATION MODE	FM
MICROPHONE ELEMENT	Dynamic, Cardioid
FREQUENCY RESPONSE	50-15,000Hz
POWER REQUIREMENT	3V (2 × 1.5V AA Pencil Cells)
CURRENT CONSUMPTION	≤ 150mA
CONTROLS	Microphone ON/OFF switch
INDICATION	Channel Frequency Display
DIMENSIONS	∅55 (L 250) mm
WEIGHT	220g (w/o battery)

SPECIFICATIONS	RECEIVER
AUDIO OUTPUT	Bal. 0dBu, Unbal. -10dBu
SIGNAL TO NOISE RATIO	>90dB
DISTORTION	≤1%
FREQUENCY RESPONSE	50-15,000Hz
POWER REQUIREMENT	220V-240V AC 50Hz for AC Adaptor (supplied alongwith)
CONTROLS	ON/OFF Switch, Volume Controls for Channel A & B
INDICATIONS	LEDs for RF & Audio Signal, Channel Frequency Display
DIMENSIONS	W210 × H42 × D147 mm
WEIGHT	405g

AWM-700®UL2 Dual PA UHF Wireless Microphones



- Elegant & affordable high performance dual channel UHF wireless microphone available in different frequencies.
- Sturdy table-top dual channel receiver with frequency display.
- Separate volume control for both channels on the front panel of the receiver.
- Two bodypack transmitters, each operating on 2 × 1.5V AA pencil cells.
- Separate balanced audio output from each channel through XLR connector and an unbalanced mixed output through 6.3 mm (1/4") jack socket available from the receiver.
- Receiver operates on 12V DC through an AC adaptor supplied along with the transmitter.
- Ideal for: PA Applications... Stage & Auditoriums... Stadia... Seminar Halls... Places of Worship... Recreation Centres...

SPECIFICATIONS	TRANSMITTER
RF OUTPUT POWER	15mW (Max.)
FREQUENCY STABILITY	±0.005%
MODULATION MODE	FM
MICROPHONE ELEMENT	Condenser, Omnidirectional
FREQUENCY RESPONSE	80-15,000Hz
POWER REQUIREMENT	3V (2 × 1.5V AA Pencil Cells)
CURRENT CONSUMPTION	≤ 130mA
CONTROLS	Microphone ON/OFF switch, Volume Control
INDICATIONS	Red LED for Transmitter ON, Frequency Display
DIMENSIONS	W67 × H32 × D95 mm
WEIGHT	60g (w/o battery)

SPECIFICATIONS	RECEIVER
AUDIO OUTPUT	Bal. 0dBu, Unbal. -10dBu
SIGNAL TO NOISE RATIO	>90dB
DISTORTION	≤1%
FREQUENCY RESPONSE	50-15,000Hz
POWER REQUIREMENT	220V-240V AC 50Hz for AC Adaptor (supplied alongwith)
CONTROLS	ON/OFF Switch, Volume Controls for Channel A & B
INDICATIONS	LEDs for RF & Audio Signal, Channel Frequency Display
DIMENSIONS	W210 × H42 × D147 mm
WEIGHT	405g



PA Wireless Microphones

AWM-700®UHL

Dual PA UHF Wireless Microphones



- Elegant & affordable high performance dual channel UHF wireless microphone available in different frequencies.
- Sturdy table-top dual channel receiver with frequency display.
- Separate volume control for both channels on the front panel of the receiver.
- One handheld dynamic transmitter and one Bodypack transmitter, each operating on 2 × 1.5V AA pencil cells.
- Separate balanced audio output from each channel through XLR connector and an unbalanced mixed output through 6.3 mm (1/4") jack socket available from the receiver.
- Receiver operates on 12V DC through an AC adaptor supplied along with the transmitter.
- Ideal for: PA Applications... Stage & Auditoriums... Stadia... Seminar Halls... Places of Worship... Recreation Centres...

SPECIFICATIONS	HANDHELD TX.	BODYPACK TX.	SPECIFICATIONS	RECEIVER
RF OUTPUT POWER	10mW (Max.)	15mW (Max.)	AUDIO OUTPUT	Bal. 0dBu, Unbal. -10dBu
MODULATION MODE	FM	FM	SIGNAL TO NOISE RATIO	>90dB
MICROPHONE ELEMENT	Dynamic, Cardioid	Condenser, Omnidirectional	DISTORTION	≤1%
FREQUENCY RESPONSE	50-15,000Hz	80-15,000Hz	FREQUENCY RESPONSE	50-15,000Hz
POWER REQUIREMENT	3V (2 × 1.5V AA Pencil Cells)	3V (2 × 1.5V AA Pencil Cells)	POWER REQUIREMENT	220V-240V AC 50Hz from AC Adaptor (supplied alongwith)
CURRENT CONSUMPTION	≤ 150mA	≤ 130mA	CONTROLS	ON/OFF Switch, Volume Control for Channel A & B
CONTROLS	Mic ON/OFF Switch	ON/OFF Switch, Vol. Control	INDICATIONS	LEDs for RF & Audio Signal, Channel Frequency Display
INDICATION	Channel Frequency Display	Red LED for Transmitter ON, Frequency Display	DIMENSIONS	W210 × H42 × D147 mm
DIMENSIONS	∅55 (L 250) mm	W67 × H32 × D95 mm	WEIGHT	405g
WEIGHT	220g (w/o battery)	60g (w/o battery)		

AWM-700®UH

PA UHF Wireless Microphone



- Elegant & affordable high performance single channel UHF wireless microphone available in different frequencies.
- Sturdy table-top receiver with frequency display.
- Volume control knob on the front panel of the receiver.
- One handheld dynamic transmitter, operating on 2 × 1.5V AA pencil cells.
- Separate balanced output through XLR connector and an unbalanced output through 6.3 mm (1/4") jack socket is available from the receiver.
- Receiver operates on 12V DC through an AC adaptor supplied along with the transmitter.
- Ideal for: PA Applications... Stage & Auditoriums... Stadia... Seminar Halls... Places of Worship... Recreation Centres...

SPECIFICATIONS	TRANSMITTER	SPECIFICATIONS	RECEIVER
RF OUTPUT POWER	10mW (Max.)	AUDIO OUTPUT	Bal. 0dBu, Unbal. -10dBu
FREQUENCY STABILITY	±0.005%	SIGNAL TO NOISE RATIO	>90dB
MODULATION MODE	FM	DISTORTION	≤1%
MICROPHONE ELEMENT	Dynamic, Cardioid	FREQUENCY RESPONSE	50-15,000Hz
FREQUENCY RESPONSE	50-15,000Hz	POWER REQUIREMENT	220V-240V AC 50Hz from AC Adaptor (supplied alongwith)
POWER REQUIREMENT	3V (2 × 1.5V AA Pencil Cells)	CONTROLS	ON/OFF Switch, Volume Control
CURRENT CONSUMPTION	≤ 150mA	INDICATIONS	LEDs for RF & Audio Signal, Channel Frequency Display
CONTROLS	Microphone ON/OFF switch	DIMENSIONS	W210 × H42 × D147 mm
INDICATION	Channel Frequency Display	WEIGHT	372g
DIMENSIONS	∅55 (L 250) mm		
WEIGHT	220g (w/o battery)		

AWM-700®UL PA UHF Wireless Microphone



- Attractive and versatile high performance single channel UHF wireless microphone available in different frequencies.
- Receiver has built-in 6.3 mm (1/4") jack for unbalanced audio output and XLR connector for balanced audio output.
- Volume control knob & Frequency display on the front panel of the receiver.
- One bodypack transmitter, operating on 2 x 1.5V AA pencil cells.
- Bodypack transmitter has a two position slide switch for ON/OFF and one volume control.
- Receiver operates on 12V DC through an AC adaptor supplied along with the transmitter.
- Ideal for: PA Applications... Stage & Auditoriums... Stadia... Seminar Halls... Places of Worship... Recreation Centres...

SPECIFICATIONS	TRANSMITTER
RF OUTPUT POWER	15mW (Max.)
MODULATION MODE	FM
MICROPHONE ELEMENT	Condenser, Omnidirectional
DYNAMIC RANGE	80dB
FREQUENCY RESPONSE	80-15,000Hz
CURRENT CONSUMPTION	≤ 130mA
POWER REQUIREMENT	3V (2 × 1.5V AA Pencil Cells)
CONTROLS	ON/OFF Switch, Volume Control,
INDICATIONS	Red LED for indicating transmitter ON, Frequency Display
DIMENSIONS	W67 × H32 × D95 mm
WEIGHT	60g (w/o battery)

SPECIFICATIONS	RECEIVER
AUDIO OUTPUT	Bal. 0dBu, Unbal. -10dBu
SIGNAL TO NOISE RATIO	>90dB
DISTORTION	≤1%
FREQUENCY RESPONSE	50-15,000Hz
DYNAMIC RANGE	>90dB
POWER REQUIREMENT	240V AC 50Hz from AC Adaptor (supplied along with)
CONTROLS	ON/OFF Switch, Volume Control
INDICATIONS	LEDs for RF & Audio Signal, Channel Frequency Display
DIMENSIONS	W210 × H42 × D147 mm
WEIGHT	372g

ABW-400®UH PA UHF Wireless Microphone



- Attractive and versatile high performance single channel UHF wireless microphone available in different frequencies.
- Bodypack receiver has built-in 6.3 mm (1/4") jack plug which provides unbalanced audio output.
- Volume control knob with RF & POWER LED on the front side of the receiver.
- One handheld dynamic transmitter, operating on 2 x 1.5V AA pencil cells.
- Receiver has a three position slide switch for ON/STANDBY/OFF position and operates on 2 x 1.5V AA pencil cells.
- Ideal for: PA Applications... Stage & Auditoriums... Stadia... Seminar Halls... Places of Worship... Recreation Centres...

SPECIFICATIONS	TRANSMITTER
RF OUTPUT POWER	10mW (Max.)
FREQUENCY STABILITY	±0.005%
MODULATION MODE	FM
MICROPHONE ELEMENT	Dynamic, Cardioid
FREQUENCY RESPONSE	50-15,000Hz
POWER REQUIREMENT	3V (2 × 1.5V AA Pencil Cells)
CURRENT CONSUMPTION	≤ 150mA
CONTROLS	Microphone ON/OFF switch
INDICATION	LED for microphone ON
DIMENSIONS	∅55 (L 250) mm
WEIGHT	220g (w/o battery)

SPECIFICATIONS	RECEIVER
AUDIO OUTPUT	Unbal. -10dBu
SIGNAL TO NOISE RATIO	>90dB
DISTORTION	≤ 1%
FREQUENCY RESPONSE	50-15,000Hz
POWER REQUIREMENT	3V (2 × 1.5V AA Pencil Cells)
CURRENT CONSUMPTION	≤ 150mA
CONTROLS	ON/OFF/SB Switch, Volume Control
INDICATIONS	LEDs for Power & RF Signal
DIMENSIONS	W62 × H128 × D26 mm
WEIGHT	65g (w/o battery)



PA Wireless Microphones

ABW-400®UL PA UHF Wireless Microphone



SPECIFICATIONS	TRANSMITTER
RF OUTPUT POWER	15mW (Max.)
FREQUENCY STABILITY	±0.005%
MODULATION MODE	FM
MICROPHONE ELEMENT	Condenser, Ominidirectional
FREQUENCY RESPONSE	80-15,000Hz
POWER REQUIREMENT	3V (2 × 1.5V AA Pencil Cells)
CURRENT CONSUMPTION	≤ 130mA
CONTROLS	Microphone ON/OFF switch, Volume Control
INDICATION	Red LED for microphone ON
DIMENSIONS	W67 × H32 × D95 mm
WEIGHT	60g (w/o battery)

- Attractive and versatile high performance single channel UHF wireless microphone available in different frequencies.
- Bodypack receiver has built-in 6.3 mm (1/4") phone plug which provides unbalanced audio output.
- Volume control knob with RF & POWER LED on the front side of the receiver.
- One Bodypack transmitter, operating on 2 x 1.5V AA pencil cells.
- Supplied with Tie-Clip as well as Neck-Band condenser microphone.
- Receiver has a three position slide switch for ON/STANDBY/OFF position and operates on 2 x 1.5V AA pencil cells.
- Ideal for: PA Applications... Stage & Auditoriums... Stadia... Seminar Halls... Places of Worship... Recreation Centres...

SPECIFICATIONS	RECEIVER
AUDIO OUTPUT	Unbal. -10dBu
SIGNAL TO NOISE RATIO	>90dB
DISTORTION	≤ 1%
FREQUENCY RESPONSE	50-15,000Hz
POWER REQUIREMENT	3V (2 × 1.5V AA Pencil Cells)
CURRENT CONSUMPTION	≤ 150mA
CONTROLS	Power ON/OFF/SB Switch, Volume Control
INDICATIONS	LEDs for Power & RF Signal
DIMENSIONS	W62 × H128 × D26 mm
WEIGHT	65g (w/o battery)

AWM-495®V2 DUAL PA VHF Wireless Microphones



SPECIFICATIONS	TRANSMITTER
RF OUTPUT POWER	<15mW (Max.)
MODULATION MODE	FM (F3E)
MICROPHONE ELEMENT	Dynamic, Cardioid
FREQUENCY RESPONSE	50-15,000Hz
DYNAMIC RANGE	80dB
CURRENT CONSUMPTION	≤ 100mA
POWER REQUIREMENT	3V (2 × 1.5V AA Pencil Cells)
ANTENNA TYPE	Internal dipole
CONTROLS	Transmitter ON/OFF switch
INDICATIONS	Red & Green LEDs for indicating transmitter ON
DIMENSIONS	Ø55 (L248) mm
WEIGHT	180g (w/o battery)

- Compact, lightweight, Dual Channel VHF Wireless Microphone System.
- Operates at Quartz Crystal Locked VHF High Band frequency and available in different frequency groups. Two transmitters with separate frequencies and one dual channel receiver.
- Internal antenna in the transmitter and two telescopic antennas in the receiver for clear and distortion free reception.
- Receiver operates on 12V DC through an AC Adaptor supplied along with the system. Each transmitter operates with a 2 x 1.5V AA Pencil Cell.
- Transmitters have 2-position ON/OFF slide switch.
- Audio output from receiver available at OUT 1 & OUT 2 individually and as mixed output at OUT 1 + 2.
- Ideal for: PA Applications... Stage & Auditoriums... Seminar Halls... Places of Worship... Recreation Centres...

SPECIFICATIONS	RECEIVER
FREQUENCY STABILITY	± 0.005% Quartz Crystal Controlled
RECEIVING METHOD	Non-diversity
AUDIO OUTPUT	Channel 1: 0-55mV/1kΩ, Channel 2: 0-55mV/1kΩ, Channel 1+2: 0-55mV/1kΩ
SIGNAL TO NOISE RATIO	> 80dB
DISTORTION	< 0.5%
FREQUENCY RESPONSE	50-15,000Hz
ANTENNA	Telescopic
POWER REQUIREMENT	240V AC 50Hz for AC adaptor (supplied along with)
CONTROLS	Power ON / OFF Switch, Volume Control for Channel-1, Volume Control for Channel-2
DIMENSIONS	W230 × H42 × D150 mm
WEIGHT	353 g

AWM-495®VHL DUAL PA VHF Wireless Microphones



SPECIFICATIONS	HANDHELD TX.	BODYPACK TX.
RF OUTPUT POWER	15mW (Max.)	15mW (Max.)
MODULATION MODE	FM (F3E)	FM (F3E)
MICROPHONE ELEMENT	Dynamic, Cardioid	Condenser, Omnidirectional
DYNAMIC RANGE	80dB	80dB
FREQUENCY RESPONSE	50-12,000Hz	80-15,000Hz
CURRENT CONSUMPTION	≤130mA	≤130mA
POWER REQUIREMENT	3V (2 × 1.5V AA Pencil Cells)	3V (2 × 1.5V AA Pencil Cells)
CONTROLS	Transmitter ON/OFF Switch	Transmitter ON/OFF Switch, Volume Control
INDICATION	Red LED for indicating transmitter ON	Red LED for indicating transmitter ON
DIMENSIONS	ø55 (L248) mm	W67 × H32 × D95 mm
WEIGHT	180g (w/o battery)	60g (w/o battery)

- Compact, lightweight, Dual Channel VHF Wireless Microphone System available in different frequency groups.
- Combination of a handheld dynamic transmitter & a bodypack transmitter for a wide variety of applications.
- Internal antennas in the transmitter and two telescopic antennas in the Receiver for clear and distortion free reception.
- Receiver operates on 12V DC through an AC Adaptor supplied alongwith the system. Each transmitter operates with a 2 x 1.5V AA Pencil Cells.
- Transmitters have 2-position ON/OFF slide switch.
- Audio output from receiver available at OUT 1 & OUT 2 individually and as mixed output at OUT 1 + 2.
- Ideal for: PA Applications... Stage & Auditoriums... Seminar Halls... Places of Worship... Recreation Centres...

SPECIFICATIONS	RECEIVER
FREQUENCY STABILITY	± 0.005% Quartz Crystal Controlled
RECEIVING METHOD	Non-diversity
AUDIO OUTPUT	Channel 1: 0-55mV / 1kΩ, Channel 2: 0-55mV / 1kΩ Channel 1+2: 0-55mV / 1kΩ
SIGNAL TO NOISE RATIO	> 80dB
DISTORTION	< 0.5%
FREQUENCY RESPONSE	50-15,000Hz
ANTENNA	Telescopic
POWER REQUIREMENT	240V AC 50Hz for AC adaptor (supplied alongwith)
CONTROLS	Power On / Off Switch, Volume Control for Channel-1, Volume Control for Channel-2
INDICATIONS	Red LED for Power ON, Green LED for RF reception on Channel-1, Green LED for RF reception on Channel-2
DIMENSIONS	W230 × H42 × D150 mm
WEIGHT	353g

AWM-495®V1 PA VHF Wireless Microphone



SPECIFICATIONS	TRANSMITTER
RF OUTPUT POWER	<15mW (Max.)
MODULATION MODE	FM (F3E)
MICROPHONE ELEMENT	Dynamic, Cardioid
DYNAMIC RANGE	80dB
FREQUENCY RESPONSE	50-15,000Hz
ANTENNA TYPE	Internal dipole
CURRENT CONSUMPTION	≤100mA
POWER REQUIREMENT	3V (2 × 1.5V AA Pencil Cells)
CONTROLS	Transmitter ON/OFF Switch
INDICATION	Green LED for indicating microphone is ON
DIMENSIONS	ø55 (L248) mm
WEIGHT	180g (w/o battery)

- Compact, lightweight, Single Channel VHF Wireless Microphone System.
- Operates at Quartz Crystal Locked VHF High Band frequency and available in different frequencies.
- Internal antenna in the Transmitter and a telescopic antenna in the Receiver for clear and distortion free reception.
- Receiver operates on 12V DC through an AC Adaptor supplied alongwith the system. The transmitter operates with 2 x 1.5V AA Pencil cells.
- Transmitter has 2-position ON/OFF slide switch.
- Audio output from receiver available through 6.3 mm (1/4") jack socket.
- Ideal for: PA Applications... Stage & Auditoriums... Seminar Halls... Places of Worship... Recreation Centres...

SPECIFICATIONS	RECEIVER
FREQUENCY STABILITY	± 0.005% Quartz Crystal Controlled
RECEIVING METHOD	Non-diversity
AUDIO OUTPUT	0-55mV/1kΩ
SIGNAL TO NOISE RATIO	> 80dB
DISTORTION	< 0.5%
FREQUENCY RESPONSE	50-15,000Hz
ANTENNA	Telescopic
POWER REQUIREMENT	240V AC 50Hz for AC adaptor (supplied along with)
CONTROLS	Power ON/OFF Switch, Output Volume Control
INDICATIONS	Red LED for Power ON, Green LED for RF reception
DIMENSIONS	W230 × H42 × D150 mm
WEIGHT	305g



PA Wireless Microphones

AWM-495[®]VL PA VHF Wireless Microphone



SPECIFICATIONS	TRANSMITTER
RF OUTPUT POWER	15mW (Max.)
MODULATION MODE	FM (F3E)
MICROPHONE ELEMENT	Condenser, Omnidirectional
DYNAMIC RANGE	80dB
FREQUENCY RESPONSE	80-15,000Hz
CURRENT CONSUMPTION	≤130mA
POWER REQUIREMENT	3V (2 × 1.5V AA Pencil Cells)
CONTROLS	Transmitter ON/OFF Switch, Volume Control
INDICATION	Red LED for indicating transmitter ON
DIMENSIONS	W67 × H32 × D95 mm
WEIGHT	60g (w/o battery)

- Compact, Lightweight, Single Channel VHF Wireless Microphone available in different frequencies.
- Operates on Quartz Crystal Locked VHF High Band frequency.
- Internal antenna in the transmitter and a telescopic Antenna on the receiver for clear and distortion free reception.
- Receiver operates on 12V DC through an AC Adaptor supplied alongwith. Transmitter operates on 2 × 1.5V AA pencil cells.
- Transmitter has 2-position slide switch for 'ON' & 'OFF' positions.
- Audio output from receiver available through 6.3 mm (1/4") jack socket.
- Ideal for: PA Applications... Stage & Auditoriums... Seminar Halls... Places of Worship... Recreation Centres...

SPECIFICATIONS	RECEIVER
FREQUENCY STABILITY	± 0.005% Quartz Crystal Controlled
RECEIVING METHOD	Non-diversity
AUDIO OUTPUT	0-55mV/1kΩ
SIGNAL TO NOISE RATIO	> 80dB
DISTORTION	< 0.5%
FREQUENCY RESPONSE	50-15,000Hz
ANTENNA	Telescopic
POWER REQUIREMENT	240V AC 50Hz from AC adaptor (supplied alongwith)
CONTROLS	Power On / Off Switch, Output Volume Control
INDICATIONS	Red LED for Power ON, Green LED for RF reception
DIMENSIONS	W230 × H42 × D150 mm
WEIGHT	305g

CWM-404U PA UHF Wireless Microphone



SPECIFICATIONS	TRANSMITTER
RF OUTPUT POWER	10mW (Max.)
MODULATION MODE	FM
MICROPHONE ELEMENT	Condenser, Cardioid
FREQUENCY RESPONSE	80-15,000Hz
POWER REQUIREMENT	3.7V (LI-ION BATTERY)
CURRENT CONSUMPTION	≤140mA
CONTROLS	ON/OFF slide switch and push Switch for mic ON/OFF
INDICATION	Display, red ring LED in the gooseneck & red round LED in the base
DIMENSIONS	W108 × H70 × D150 mm
WEIGHT	490g (without battery)

- Compact and elegant high band UHF Wireless Microphone system with four gooseneck microphones.
- Available in different frequencies (3 sets of 4 each).
- Desktop Transmitters are unidirectional condenser types, fitted with gooseneck, ON/OFF switch and display for indicating channel, frequencies, AF led array and battery bar.
- Sleek elegant receiver which can receive signals from upto 4 Desktop Transmitters.
- Individual output volume control, RF LED and AF LED for each channel provided on the front panel of the receiver.
- Separate 6.3 mm phone jack for audio output from each channel and mix out also available on the rear panel.
- Desktop transmitter operates with 3.7V Lithium-Ion Rechargeable cell.
- Receiver operates on 12V DC through an AC adaptor, supplied along with.

SPECIFICATIONS	RECEIVER
AUDIO OUTPUT	0-50mV adjustable (each channel)
S/N RATIO	>80dB
DISTORTION	<0.5%
ANTENNA TYPE	Telescopic
POWER REQUIREMENT	220V-240V AC 50Hz for AC adaptor (supplied along with)
CONTROLS	Power Switch, Output Volume Control for each channel
INDICATION	Display for Power ON, red LED for RF indication of each Channel, Green LED for AF indication of each channel
DIMENSIONS	W483 × H52 × D210 mm
WEIGHT	1.80kg

INSTALLED SOUND SERIES

These professional high quality Gooseneck Microphones are suitable for various PA applications such as on Lecterns and Podiums, Open Conferences etc. The sleek and slender design makes the microphones unobtrusive. Model GM-601LM has a ring LED indication, useful in open conferences; while GM-615M and GM-611M have a longer reach. GM-605 is of the same length as GM-601LM. AGN-500 and AGN-480 are fitted with stand mount base and are supplied with 6m twin core shielded low noise cable.

- Wide frequency response.
- High front-to-back rejection for more gain before feedback.
- Built-in XLR socket.



Unidirectional Electret Condenser Microphones

Unidirectional Dynamic Microphones

SPECIFICATIONS	GM-615M	GM-611M	GM-605	GM-601LM	AGN-500	AGN-480
FREQUENCY RESPONSE	50-18,000Hz	100-15,000Hz	100-15,000Hz	100-15,000Hz	50-15,000Hz	50-10,000Hz
IMPEDANCE	1000Ω	1000Ω	1000Ω	1000Ω	600Ω	600Ω
SENSITIVITY	5.0mV/Pa	7.0mV/Pa	7.0mV/Pa	7.0mV/Pa	2.5mV/Pa	2.0mV/Pa
POWER SOURCE	1.5V-9V DC	1.5V-9V DC	1.5V-9V DC	3V-9V DC	—	—
OVERALL LENGTH	585 mm (23")	585 mm (23")	460 mm (18")	460 mm (18")	395 mm (15.5")	470 mm (18.5")

G-622S

Strong 254 mm (10") long flexible gooseneck shaft in silver finish Exclusively designed for converting any XLR microphone into a gooseneck microphone. A female XLR connector is provided at the top for connecting any XLR microphone and a male XLR connector has been provided at the bottom for connecting the microphone cable. Fitted with stand mount base to match all Ahuja PA Microphone Stands.



G-611S

This is a mic stand adaptor for Ahuja gooseneck microphones model GM-615M, GM-611M and GM-605. It has a well styled rugged heavy duty aluminium die-cast body with a female XLR connector for directly mounting the gooseneck microphone. A male XLR connector has been provided at the bottom for connecting the cable.



- 10m twin core shielded low noise cable with in-line cell housing.
- Operates on 1.5V (1×UM-3) pencil cell provided.
- Special circuitry employed for minimal switch noise.
- Threaded brass ferrule with 5/8"×27 TPI, suitable for standard microphone stands.

GMB-6C

This is a sturdy, heavy duty base made of die-cast aluminium suitable for Ahuja electret condenser gooseneck microphones. It has a female XLR connector for directly mounting the gooseneck microphone and a male XLR socket at the rear for connecting standard microphone cable to the amplifier.



- Heavy weight housing with anti-skid feet ensures stability.
- 10m twin core shielded low noise mic cable with XLR connector & 6.3 mm (1/4") phone plug.
- Built-in cell housing for 2×UM-3 pencil cells (3V) for operating the condenser microphone.
- On/Off switch provided. Special electronic circuitry for minimal switch noise.



Wireless Desktop Microphone

AWM-630VG PA VHF Wireless Desktop Microphone



- Stylish & rugged high band VHF wireless desktop microphone & receiver available in different frequencies.
- Condenser unidirectional transmitter has a sleek gooseneck with ring LED indicator.
- Transmitter has a push-type ON/OFF switch.
- Highly sensitive table-top receiver with a telescopic antenna & noise squelch circuitry.
- Transmitter also has a male XLR connector & connecting cable so that wired mode can also be used, if required.
- Transmitter operates with 2 × 1.5V UM-3 pencil cells.
- Receiver operates on 9V DC through an AC adaptor, supplied along with.

SPECIFICATIONS	TRANSMITTER
RF OUTPUT POWER	10mW (Max.)
MODULATION MODE	FM
MICROPHONE ELEMENT	Condenser, Cardioid
FREQUENCY RESPONSE	100-12,000Hz
POWER REQUIREMENT	2 × 1.5V Pencil Cells
CURRENT CONSUMPTION	<40mA
CONTROLS	ON/OFF Switch
INDICATION	Red Ring LED in the gooseneck
DIMENSIONS	W145 × H50 × D155 mm
WEIGHT	560g (w/o battery)

SPECIFICATIONS	RECEIVER
FREQUENCY STABILITY	± 0.005%
AUDIO OUTPUT	0-50mV adjustable
SIGNAL TO NOISE RATIO	>90dB
DISTORTION	<0.5%
ANTENNA TYPE	Telescopic
POWER REQUIREMENT	220V-240V AC 50Hz for AC adaptor (supplied alongwith)
CONTROLS	Power Switch, Output Volume Control
INDICATION	Red LED for Power ON, Green & Red LEDs for Signal
DIMENSIONS	W152 × H40 × D110 mm
WEIGHT	200g

Paging Microphones



ACM-96/ACM-96CH with MULTI Tone Chime

- Robust and heavy duty Single Zone Desktop Paging Microphone.
- Sturdy, aluminium die-cast top.
- High reliability switches with integrated LED indicators.
- Flexible 300 mm (12") gooseneck and a high quality unidirectional dynamic cartridge.
- Supplied with 6m twin core shielded low noise cable terminated with 6.3 mm (1/4") phone plug.
- ACM-96CH is also provided with a multi tone electronic chime, and operates on 2 × 1.5V (UM-3) pencil cells.
- Desired chime sound level can be set through preset at the bottom side of ACM-96CH.

SPECIFICATIONS	
FREQUENCY RESPONSE	50-10,000Hz
SENSITIVITY	2.0mV/Pa
IMPEDANCE	600Ω

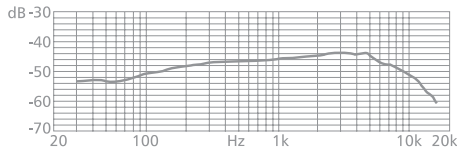
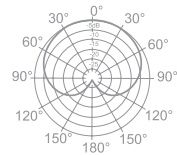

PGM-481 Gooseneck Microphone

A sleek and 585 mm (23") long gooseneck condenser microphone with natural and clear sound. Ideal for high end applications like auditoria, conference halls and podiums for VIPs.

- Suitable for use with PGB-48 base and powered by 48V phantom supply model APS-482 or equivalent.

SPECIFICATIONS

FREQUENCY RESPONSE	50-16,000Hz
SENSITIVITY	5.5mV/Pa
IMPEDANCE	200Ω
POWER REQD.	9V-52V DC
OVERALL LENGTH	585 mm (23")

PGB-48 Phantom Gooseneck Microphone Base

- An elegantly designed, sturdy & heavy duty metal base for use with a phantom gooseneck microphone PGM-481 and a suitable 48V phantom supply source APS-482.
- Provided with an ON/OFF switch and LED indication.
- Balanced output allowing longer cable length.

ABM-301M/ABM-301H Boundary Layer Microphones

Elegantly designed boundary layer microphones for table-top or stage use. Provided with push on/off mute switch, LED indicator, rubber base for reducing shock noise, and a switchable bass filter to eliminate unwanted low frequency noise. Extra smooth wide frequency response and clear, highly intelligible sound. Use with 48V phantom supply. ABM-301M is omnidirectional, and recommended for conference tables, video conferencing etc. ABM-301H is hypercardioid, and recommended for use on stage. Suitable for use with 48V phantom supply APS-482 or equivalent.

SPECIFICATIONS

FREQUENCY RESPONSE	40-16,000Hz
SENSITIVITY	15mV/Pa
IMPEDANCE	100Ω
BASS FILTER	-10dB at 80Hz
CABLE LENGTH	5.80m
POWER REQUIREMENT	9V-52V DC



APS-482 48V Phantom Supply

High quality, high reliability power supply for use with condenser microphones using 48V DC phantom supply. Fitted with ON/OFF switch, power LED and XLR microphone input and output sockets. Provided with XLR input & output sockets for connecting upto TWO phantom microphones. Suitable for use with microphones PGM-481, ABM-301M and ABM-301H. BIS approved.

SPECIFICATIONS

OPERATING VOLTAGE	240V AC 50Hz
PHANTOM SUPPLY	48V DC
MIC INPUTS	2 x Female XLR
MIC OUTPUTS	2 x Male XLR (For Amplifier)
COMPLIANCE	IS616:2017 (BIS Certified)
DIMENSIONS	W145 × H60 × D130 mm
WEIGHT	1.10kg



Special Purpose Microphones



EWM-100 Ear Worn Microphone

Innovative, ear shaped, exceptionally sleek, ultra-light Headband Microphone for Stage Shows, Classrooms, Presentations, Discourses, Places of Worship etc.

- Omnidirectional electret condenser microphone.
- Adjustable microphone length for best position.
- External windscreen to reduce wind and pop noise.
- Terminated with $\varnothing 3.5$ mm mono phone plug for use with suitable bodypack transmitter of wireless microphone systems.

SPECIFICATIONS

FREQUENCY RESPONSE	20-20,000Hz
SENSITIVITY	5.6mV/Pa
NOMINAL IMPEDANCE	2000 Ω
CABLE LENGTH	1.20m
OPERATING VOLTAGE	1.5V - 12V DC

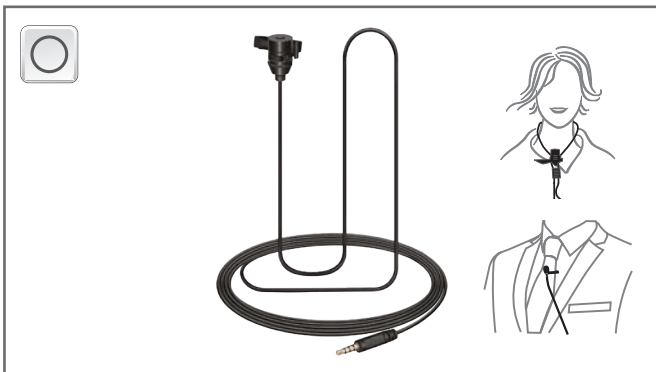

MTP-20 Lavalier Microphone

- Tie-Clip electret condenser microphone with unidirectional characteristics. Ideal for Smartphones, PC/Laptop, Camcorders DSLR, Audio Recorder etc.

SPECIFICATIONS

FREQUENCY RESPONSE	100-15,000Hz
SENSITIVITY	7.0mV/Pa
OUTPUT CONNECTION	3.5 mm (1/8") 4-Pole Plug (TRRS)
CABLE LENGTH	5m



MM-60M PA Microphone for Mobile Use

- Professional dynamic microphone for mobile applications.
- Close-to-lip speaking to avoid background noise.
- Flexible coiled cord for easy extension of wire length.

SPECIFICATIONS

FREQUENCY RESPONSE	200-6,000Hz
SENSITIVITY	2.3mV/Pa
IMPEDANCE	500 Ω

Connecting Cable for Smartphones



CC-125M Connecting Cable

- Connecting cable CC-125M facilitates the usage of any Ahuja microphone with a smartphone.
- Also provides interconnection between a line level signal from a mixer to the smartphone.
- The cable is terminated with a 6.3 mm (1/4") female mono (TS) socket on one end and a 3.5 mm (1/8") male TRRS plug on other end.
- The length of shielded cable is 1.25m

85
YEARS+
SINCE 1940

Hallmark of Reliability!



Audio Interface

Audio interface is a stand alone recording device. The interface will have various inputs to allow you to record your mics, instruments, and line level audio devices. It can have digital inputs. An audio interface will provide USB output to connect to a PC and also have outputs for user to connect studio speakers or studio headphones.

AHUJA offers two models of Audio Interface, for an outstanding performance in different applications.

Applications

Conferencing | E-Teaching | E-Court | Podcasters | Youtubers | Vloggers

Musicians | Singers | DJs

AI-202

2×2 USB Audio Interface

- Studio quality(16Bit/48kHz) Digital Recording.
- Features two inputs (Mic/Line & Instrument Level) and two outputs.
- Extreme low-Latency digital streaming.
- Switchable Phantom power.
- Supports Windows/Android & Mac iOS.
- Compatible with popular DAW softwares.
- USB 2.0 Bus-powered.
- Compact durable Aluminium body.



AI-22

2×2 USB Audio Interface

- Studio Quality(16Bit/48kHz) Digital Recording.
- Features two inputs (Mic/Line & Instrument Level) and two outputs.
- Extreme low-Latency digital streaming.
- Switchable Phantom power.
- Supports Windows/Android & Mac iOS.
- Compatible with popular DAW softwares.
- USB 2.0 Bus-powered.
- Compact durable Aluminium body.



SPECIFICATIONS	AI-202	AI-22
MICROPHONE INPUT / LINE INPUT		
TYPE	Combo XLR Female X2/ 2 x 6.3 mm TRS, Balanced	Combo XLR Female 6.3 mm TRS balanced
INPUT IMPEDANCE (Balanced)	2.2kΩ / 18kΩ	2.2kΩ / 18kΩ
THD+N (1kHz @ +0dBu Output)	<0.5%	<0.5%
S/N RATIO (1kHz @ +0dBu Output)	>55dB	>55dB
INPUT LEVEL (0dBu Gain, 1kHz)	3mV ± 1mV / 45mV ± 2mV	3mV ± 1mV / 35mV ± 2mV
PHANTOM POWER	+48 VDC at both XLR Female only	+48 VDC at XLR Female only
INSTRUMENT INPUT		
TYPE	2 x 6.3 mm TRS, Balanced	1 x 6.3 mm Female, Unbalanced
INPUT IMPEDANCE	1MΩ	1MΩ
INPUT LEVEL (0dBu Gain, 1kHz)	3.50mV ± 1mV	285mV ± 10mV
FREQUENCY RESPONSE	20-20,000Hz	20-20,000Hz
PAD ON	-18dB	—
OUTPUT L & R		
TYPE	2 x 6.3 mm Female, Unbalanced	2 x 6.3 mm Female, Unbalanced
Maximum Output ±20mV	550mV	775mV
HEADPHONE OUTPUT		
TYPE	6.3 mm Active Stereo	6.3 mm Active Stereo
MAXIMUM OUTPUT ±20mV	300mV/ch. @ 8Ω Load	300mV/ch. @ 8Ω Load
DIGITAL AUDIO		
BIT DEPTH	16 bit	16 bit
INTERNAL SAMPLE FREQUENCY SELECTIONS	44.1, 48 kHz	44.1, 48 kHz
POWER	USB Bus Powered	USB Bus Powered
DIMENSIONS		
WEIGHT	W175 × H58 × D123 mm	W175 × H58 × D123 mm
	615g	550g



Hallmark of Reliability!



Portable PA

Convenient, Compatible & Complete:

AHUJA Portable PA Equipment are attractive, ready to use amplifier and speaker all supplied in one integrated package.

Applications

Tour Guides | Traffic Police | Class Rooms | Mobile Announcements
Religious Discourses | Private Parties | Clubs & Community Centers

PA Driver Units



AU-40®
40W/16Ω



AU-60®
60W/16Ω



AU-40®XT
40W/100V



AU-50®XT
50W/100V

- Weatherproof and rugged construction.
- High SPL, crisp penetrating sound.
- Voice coils precision-wound on an aluminium bobbin for efficient heat dissipation.
- Models AU-40®XT and AU-50®XT have a built-in 100V transformer with easily selectable power taps/impedance by changing the position of the rotary switch at the rear.
- Degree of protection IP66 provided, when mounted on a reflex horn, against foreign particles such as dust and jets of water thus making them ideal for outdoor use. Meets EN 60529.

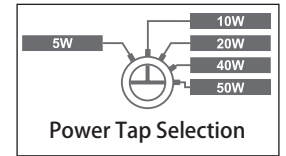
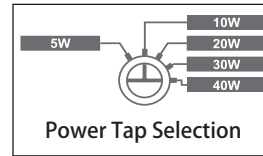

SPECIFICATIONS	AU-40®	AU-60®	AU 40®XT	AU 50®XT
INPUT POWER	40W RMS/60W Max.	60W RMS/90W Max.	40W RMS/60W Max.	50W RMS/70W Max.
IMPEDANCE/POWER TAPS	16Ω	16Ω	On 100V Line	On 100V Line
	—	—	250Ω/40W, 330Ω/30W	200Ω/50W, 250Ω/40W
	—	—	500Ω/20W, 1kΩ/10W	500Ω/20W, 1kΩ/10W
	—	—	2kΩ/5W	2kΩ/5W
FREQUENCY RESPONSE	160-7,000Hz	160-7,000Hz	160-7,000Hz	160-7,000Hz
SPL at 1kHz	112.5dB/1W/1m 128.5dB/40W/1m	113.5dB/1W/1m 132dB/60W/1m	112.5dB/1W/1m 128.5dB/40W/1m	113dB/1W/1m 130dB/50W/1m
TEMPERATURE RANGE	-30° to + 70°C	-30° to + 70°C	-30° to + 70°C	-30° to + 70°C
THROAT COUPLING		1-3/8" - 18TPI, Throat Couple No.1		
DIMENSIONS	Ø116 x H98 mm	Ø126 x H100 mm	Ø150 x H137 mm	Ø150 x H143 mm
WEIGHT	1.65kg	1.95kg	2.20kg	2.45kg
MATERIAL		Die-cast Aluminium Acoustic Head (Flange)		

PA Horn Speakers

EHC-10 10W/8Ω / EHC-10XT 10W/100V

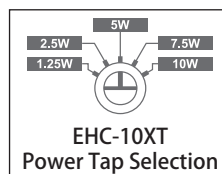

SPECIFICATIONS	EHC-10	EHC-10XT
INPUT POWER	10W RMS/15W Max.	10W RMS/15W Max.
IMPEDANCE / POWER TAPS	8Ω	10/7.5/5/2.5/1.25W
FREQUENCY RESPONSE	350-7,000Hz	350-7,000Hz
SPL at 1kHz	102dB/1W/1m, 112dB/10W/1m	102dB/1W/1m, 112dB/10W/1m
DIMENSIONS	180 × 130 (L195) mm	180 × 130 (L215) mm
WEIGHT	930g	1.17kg
MATERIAL	ABS (UV Protected)	ABS (UV Protected)

- Compact, sturdy and light weight weather proof horn speakers for a variety of mobile PA and installed PA applications.
- Available in low impedance 8Ω version as EHC-10 and high impedance 100V version as EHC-10XT.
- Features high acoustical efficiency together with intelligible and effective penetrating sound.
- Constructed with tough UV protected ABS plastic components.
- Provided with strong metal bracket for rigid mounting. Stand mounting bolts are in stainless steel.
- Fitted with 0.6m (2') 2-core sheathed speaker cable, secured through a water-tight, tug-proof cable gland.
- They meet European Union regulations and comply with low voltage directive standard EN 60065. Degree of protection IP66 is provided against foreign particles such as dust and jets of water, thus making them ideal for outdoor use.

Low Impedance PA Horn Speakers



UHC-30
30W/8Ω

UHC-25
25W/8Ω

UHC-15
15W/8Ω



SUH-40
40W/16Ω

SUH-25M
25W/8Ω

SUH-15M
15W/8Ω

- Ahuja high quality, weather proof horn speakers are compact, light weight and rugged. They are moulded in tough UV protected ABS plastic for longer lasting finish.
- Designed for acoustical efficiency providing a high SPL for a clean intelligible sound and effective sound penetration.
- Voice coils are precision-wound on an aluminium bobbin for good heat dissipation from the coil, thereby improving efficiency and reliability.
- Fitted with 0.6m (2') 2-core sheathed speaker cable, secured through a water-tight, tug-proof cable gland.
- These models have been provided with robust metal brackets/stands rotating through 270°. Rectangular models are particularly suitable for mounting on vehicles & boats.
- They meet European Union regulations and comply with low voltage directive standard EN 60065. Degree of protection IP66 is provided against foreign particles such as dust and jets of water, thus making them ideal for outdoor use.

UV Protected ABS Bell, Reflector and Back Cover. External Stand Mounting Bolts in Stainless Steel

SPECIFICATIONS	UHC-30	UHC-25	UHC-15	SUH-40	SUH-25M	SUH-15M
INPUT POWER	30W RMS/45W Max.	25W RMS/38W Max.	15W RMS/23W Max.	40W RMS/60W Max.	25W RMS/38W Max.	15W RMS/23W Max.
IMPEDANCE	8 Ω	8 Ω	8 Ω	16 Ω	8 Ω	8 Ω
FREQUENCY RESPONSE	240-10,000Hz	250-10,000Hz	275-7,000Hz	180-7,000Hz	250-10,000Hz	275-7,000Hz
SPL at 1kHz	108dB/1W/1m 123dB/30W/1m	108dB/1W/1m 122dB/25W/1m	106dB/1W/1m 118dB/15W/1m	112.5dB/1W/1m 128.5dB/40W/1m	108dB/1W/1m 122dB/25W/1m	106dB/1W/1m 118dB/15W/1m
DIMENSIONS	Ø313 (L285) mm	Ø274 (L280) mm	Ø205 (L245) mm	400 x 200 (L385) mm	315 x 165 (L290) mm	253 x 152 (L265) mm
WEIGHT	1.98kg	1.94kg	1.44kg	3.20kg	1.90kg	1.50kg
MATERIAL	ABS (UV Protected)	ABS (UV Protected)	ABS (UV Protected)	ABS (UV Protected)	ABS (UV Protected)	ABS (UV Protected)



100V PA Horn Speakers



UHC-30XT
30W/100V

UHC-25XT
25W/100V

UHC-15XT
15W/100V



SUH-40XT
40W/100V

SUH-25MT
25W/100V

SUH-15MT
15W/100V

- Ahuja high quality, weather proof horn speakers are compact, light weight and rugged. They are moulded in tough UV protected ABS plastic for longer lasting finish.
- The specifications and construction of these are similar to the low impedance horn speakers. These models have been provided with 100V line matching transformers with multiple taps/impedance easily selectable by changing the position of the rotary switch at the rear of the sealed assembly.
- These 100V models are ideal for installations where long speaker cables are used, to avoid power loss in the cables.
- Rectangular models are particularly suitable for areas where directivity of sound is of importance.
- They meet European Union regulations and comply with low voltage directive standard EN 60065. Degree of protection IP66 is provided against foreign particles such as dust and jets of water, thus making them ideal for outdoor use.

Power Tap Selection UHC-25XT

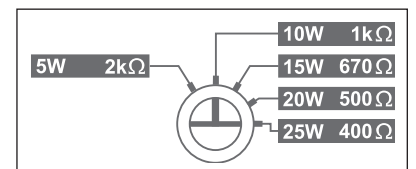

UV Protected ABS Bell, Reflector and Back Cover. External Stand Mounting Bolts in Stainless Steel

SPECIFICATIONS	UHC-30XT	UHC-25XT	UHC-15XT	SUH-40XT	SUH-25MT	SUH-15MT
INPUT POWER	30W RMS/45W Max.	25W RMS/38W Max.	15W RMS/23W Max.	40W RMS/60W Max.	25W RMS/38W Max.	15W RMS/23W Max.
POWER TAPS	30/25/20/15/10/5W	25/20/15/10/5W	15/10/5/2.5W	40/30/20/10/5W	25/20/15/10/5W	15/10/5/2.5W
IMPEDANCE	330/400/500/670/ 1k/2kΩ	400/500/670/ 1k/2kΩ	670/1k/2k/4kΩ	250/330/500/ 1k/2kΩ	400/500/670/ 1k/2kΩ	670/1k/2k/4kΩ
FREQUENCY RESPONSE	240-10,000Hz	250-10,000Hz	275-7,000Hz	180-7,000Hz	250-10,000Hz	275-7,000Hz
SPL at 1kHz	108dB/1W/1m 123dB/30W/1m	108dB/1W/1m 122dB/25W/1m	106dB/1W/1m 118dB/15W/1m	112.5dB/1W/1m 128.5dB/40W/1m	108dB/1W/1m 122dB/25W/1m	106dB/1W/1m 118dB/15W/1m
DIMENSIONS	Ø313 (L315) mm	Ø274 (L310) mm	Ø205 (L270) mm	400 x 200 (L422) mm	315 x 165 (L320) mm	253 x 152 (L293) mm
WEIGHT	2.39kg	2.34kg	1.78kg	3.90kg	2.30kg	1.90kg
MATERIAL	ABS (UV Protected)	ABS (UV Protected)	ABS (UV Protected)	ABS (UV Protected)	ABS (UV Protected)	ABS (UV Protected)

AMH-402T 40 WATTS



AMH-402T, a 2-way high efficiency, high fidelity PA Music Horn Speaker. It uses a 15.24 cm (6") Kevlar cone woofer and a 2.54 cm (1") phenolic dome tweeter. Thus it combines the high efficiency of a horn with the wide frequency response obtained by using a 2-way woofer tweeter combination. Housed in a beautifully designed UV protected ABS plastic housing, the music horn is weather protected which makes it ideal for outdoor as well as indoor applications.

- Unique concept used to create a well-engineered 2-way PA Music Horn with high efficiency, long throw, and wide frequency response.
- Sound quality of exceptional richness, clarity and fidelity. Ideal for music as well as announcements.
- Rugged & sturdy construction with aesthetically superior finish. UV protected ABS plastic housing.
- Comprises of a highly efficient 15.24 cm (6") Kevlar cone LF driver and a 2.54 cm (1") HF driver for wider frequency response and higher SPL.
- Easy power tap selection on a terminal strip with a 2-core cable. Strong mounting bracket for rigid mounting.
- Ideal for both Indoor and Outdoor applications: Railway Stations, Educational Institutions, Religious Places, Stadiums, Amusement Parks, Factories, Cruise Liners etc.

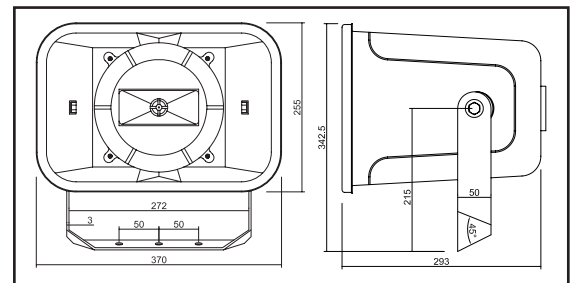
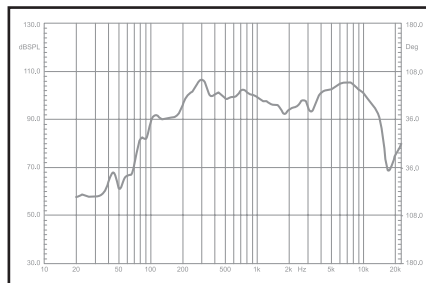

SPECIFICATIONS	AMH-402T
INPUT POWER	40W RMS
POWER TAPS	40/20/10/5W
IMPEDANCE	250/500/1k/2kΩ
FREQUENCY RESPONSE	120-16,000Hz
SPL at 1kHz	98dB/1W/1m; 114dB/40W/1m
DIMENSIONS	W370 × H255 × D300 mm
WEIGHT	5.90kg
MATERIAL	ABS (UV Protected)

PA Horn Speaker for Vehicles

AHC-15 15W/8Ω

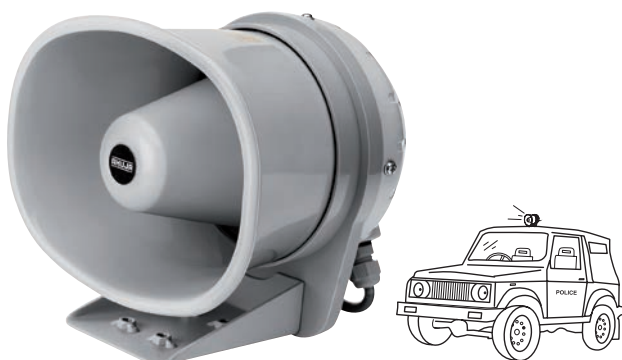

- Compact and rugged horn speaker AHC-15 specifically designed for Automobile applications like Siren, Playback of pre-recorded content or real-time reinforcement through microphone.
- Delivers high SPL for a clean intelligible sound and effective penetration.
- Weather proof housing makes AHC-15 versatile to be either mounted on the top of the vehicle or affixed in the hood / bonnet of the vehicle.
- Heavy duty metal bracket offers the most stable and road-worthy mounting arrangement.

SPECIFICATIONS	
INPUT POWER	15W RMS/23W Max.
IMPEDANCE	8Ω
FREQUENCY RESPONSE	300-7,000Hz
SPL at 1kHz	106dB/1W/1m, 118dB/15W/1m
DIMENSIONS	170 x 155 (L157) mm
WEIGHT	1.33kg
MATERIAL	ABS (UV Protected)



PA Horns

WFA, WFB PA Reflex Horns



AHUJA heavy duty aluminium horns are ideal for many large outdoor installations. Rugged construction and fitted with a protective PVC ring on the flare.

Acoustically well designed, these match Ahuja driver units for an efficient, powerful and clear sound.

SPECIFICATIONS	WFA	WFB
BELL DIA	533.4 mm (21")	457.2 mm (18")
CUT-OFF FREQUENCY	160Hz	190Hz
WEIGHT	2.17kg	1.87kg

ATH-22 PA Trumpet Horn



Rugged Ahuja Trumpet Horn, specially made for high efficiency, optimum frequency response and long throw. Suitable for all Ahuja Driver Units.

SPECIFICATIONS	ATH-22
BELL DIA	558.8 mm (22")
CUT-OFF FREQUENCY	160Hz
WEIGHT	2.27kg

DIAPHRAGMS



AU-35/AU-40/AU-60



AU-40XT/AU-50XT

The high quality diaphragms used in AHUJA Driver Units are specially shaped, reinforced phenolic diaphragms with a precision-wound voice coil on ALUMINIUM former for good heat dissipation. The rigid assembly offers high acoustic properties and is most indestructible in normal service. The self-centering design requires little skill to replace the diaphragm.

SCM-30[®]
20W/16Ω

SCM-30^{®T}
20W/100V

Column Speakers

SCM SERIES

- For Indoor & Outdoor applications such as in Halls, Auditoria, Airport Lounges.
- Weather resistant — for use under roof eaves. Foam layer to protect speakers from dust.
- Array of speakers radiate forward sound beam for wider audience coverage.
- Mounting clamps & hardware supplied.

SCM-30[®]/SCM-30^{®T} SCM-15/SCM-15T

- Column speakers in metal cabinet in powder coated finish.
- Speaker connections through a terminal strip at the rear.
- Available in 100V line matching transformer version and low impedance version.

SCM-15
10W/8Ω

SCM-15T
10W/100V



SPECIFICATIONS	SCM-15/SCM-15T	SCM-30 [®] /SCM-30 ^{®T}
INPUT POWER	10W RMS 15W Max.	20W RMS 30W Max.
POWER TAPS	10W, 10/7.5/5W	20W, 20/15/10W
IMPEDANCE/VOLTAGE	8Ω, 100V	16Ω, 100V
FREQUENCY RESPONSE	150-10,000Hz	150-10,000Hz
SPL at 1kHz (1W/1m)	92dB	95dB
SPEAKERS	2 × 152.4 mm (6") × 101.6 mm (4")	4 × 152.4 mm (6") × 101.6 mm (4")
DIMENSIONS	W165 × H455 × D145 mm	W165 × H885 × D145 mm
WEIGHT	2.83kg 2.85kg	5.50kg 6.07kg

ASC SERIES

- For Indoor & Outdoor applications such as in Halls, Auditoria, Airport Lounges.
- Weather resistant — for use under roof eaves. Foam layer to protect speakers from dust.
- Array of speakers radiate forward sound beam for wider audience coverage.
- Mounting clamps & hardware supplied.



ASC-310T/ASC-315T/ ASC-320T

- Slim, compact, aesthetically designed column speakers.
- Off-white colour to integrate with most interiors.
- Aluminium extruded cabinet with moulded plastic covers, metal mesh grille.
- 100V line matching transformer with rotary switch for power tap selection.

ASC-20T/ASC-40T

- Column speakers in grey colour for indoor & outdoor applications.
- Aluminium extruded cabinet with moulded plastic covers. Metal mesh grille in black colour.
- 100V transformer with rotary switch for power tap selection.

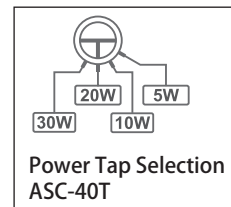
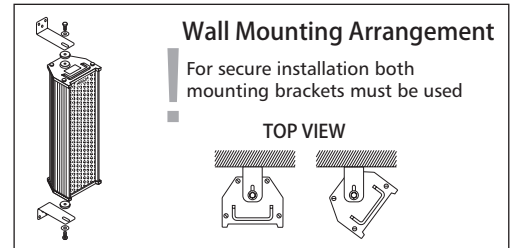

ASC-40T
30W/100V

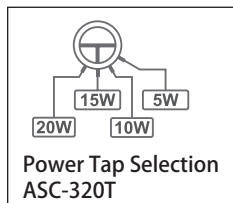

SPECIFICATIONS	ASC-310T	ASC-315T	ASC-320T	ASC-20T	ASC-40T
INPUT POWER	10W RMS/15W Max.	15W RMS/23W Max.	20W RMS/30W Max.	15W RMS/23W Max.	30W RMS/45W Max.
POWER TAPS	10/7.5/5/2.5W	15/10/5/2.5W	20/15/10/5W	15/10/5/2.5W	30/20/10/5W
IMPEDANCE/VOLTAGE	100V	100V	100V	100V	100V
FREQUENCY RESPONSE	150-15,000Hz	150-15,000Hz	150-15,000Hz	150-10,000Hz	150-10,000Hz
SPL at 1kHz	90dB/1W/1m	91.5dB/1W/1m	93dB/1W/1m	92dB/1W/1m	95dB/1W/1m
SPEAKERS	2 ×	3 ×	4 ×	2 ×	4 ×
DIMENSIONS	127 mm (5") × 76.2 mm (3")	127 mm (5") × 76.2 mm (3")	127 mm (5") × 76.2 mm (3")	152.4 mm (6") × 101.6 mm (4")	152.4 mm (6") × 101.6 mm (4")
WEIGHT	1.90kg	2.50kg	3.10kg	2.70kg	5.10kg





CS-451T

Compact ceiling speaker with clamps to flush mount without screws.

- 12.7 cm (5") Full Range Speaker, 4W/100V.
- Easy mounting with spring loaded wing clamps.
- Stylish plastic grille in white colour.
- Ideal for **Speech and Music in Hotels... Restaurants... Offices...**

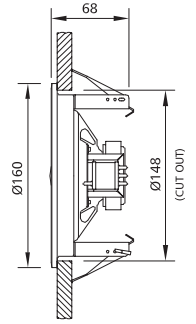

CS-663T

High quality flush mount ceiling speaker.

- 15.24 cm (6") Full Range Speaker, 6W/100V.
- Easy selection of power taps through change of receptacle on 100V LMT.
- Aesthetically designed plastic grille and easy mounting with spring loaded clamps.
- Ideal for **Hotels... Shopping Malls... Offices...**

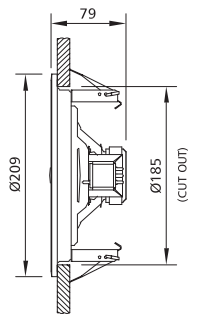

CS-662T

High quality flush mount ceiling speaker for indoor public address and background music installations. Screw mounting grille.

- 15.24 cm (6") Full Range Speaker, 6W/100V.
- ABS plastic grille with attractive design.
- Easy selection of power taps through change of receptacle on 100V LMT.
- Ideal for **Hotels... Shopping Malls... Offices...**

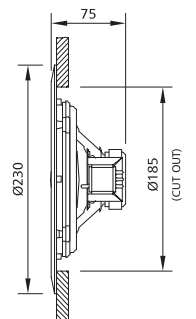

SPECIFICATIONS	CS-451T	CS-663T	CS-662T
INPUT POWER	4W RMS	6W RMS	6W RMS
POWER TAPS ON 100V	4/2/1W	6/3/1.5W	6/3/1.5W
IMPEDANCE	2.5k/5k/10kΩ	1.6k/3.3k/6.6kΩ	1.6k/3.3k/6.6kΩ
FREQUENCY RESPONSE	80-15,000Hz	60-15,000Hz	60-15,000Hz
SPL at 1kHz (1W/1m)	92dB	92dB	92dB
DIMENSIONS	Ø160 × H68 mm	Ø209 × H79 mm	Ø230 × H75 mm
WEIGHT	640g	835g	670g



CS-5044T

Flush mounting ceiling speaker with an attractive, ultra-modern ABS plastic grille. Stylish good looks make this ideally suitable for fashionable showrooms, restaurants and offices.

- 12.7 cm (5") Full Range Speaker with power taps of 4/2/1W.
- 4 Watts continuous power handling capacity.
- Easy mounting with spring loaded wing clamps.
- 100V operation with easy selection of power taps through a terminal block.
- Ideal for Offices... Restaurants... Hotels... Hospitals... Shopping Malls... Gymnasiums...

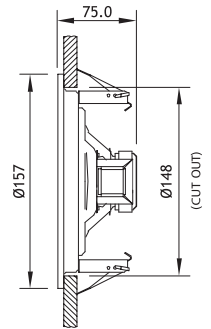

CS-6066T

Flush mounting ceiling speaker with an elegant, ultra-modern ABS plastic grille. Attractive looks make this ideally suitable for fashionable showrooms, restaurants and offices.

- 15.24 cm (6") Full Range Speaker with power taps of 6/3/1.5W.
- 6 Watts continuous power handling capacity.
- Easy mounting with spring loaded wing clamps.
- 100V operation with easy selection of power taps through a terminal block.
- Ideal for Offices... Restaurants... Hotels... Hospitals... Shopping Malls... Gymnasiums...

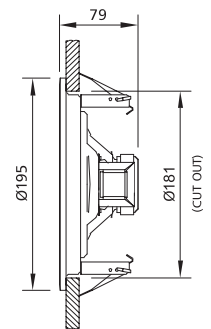

BS-6462T

Metal box speaker for sound system installations in Railway Coaches, Industrial Establishments etc.. Powder coated sturdy metal enclosure. Vandal-proof.

- 15.24 cm (6") × 10.16 cm (4") Full Range Speaker, 6W/100V.
- Can be wall mounted also. Key holes provided on rear.

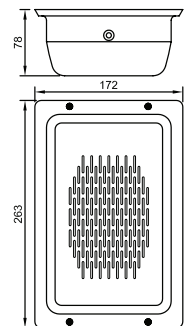

SPECIFICATIONS	CS-5044T	CS-6066T	BS-6462T
INPUT POWER	4W RMS	6W RMS	6W RMS
POWER TAPS ON 100V	4/2/1W	6/3/1.5W	6/3/1.5W
IMPEDANCE	2.5k/5k/10kΩ	1.6k/3.3k/6.6kΩ	1.6k/3.3k/6.6kΩ
FREQUENCY RESPONSE	80-15,000Hz	60-15,000Hz	150-10,000Hz
SPL at 1kHz (1W/1m)	92dB	92dB	91dB
DIMENSIONS	Ø157 × H75 mm	Ø195 × H79 mm	W172 × H263 × D78 mm
WEIGHT	660g	820g	1.40kg





CS-3061T

Attractive, compact ceiling speaker with excellent clarity and intelligibility. Moulded ABS plastic frame with spring mounting clamps.

- 7.62 cm (3") Full Range Speaker, 6W/100V
- 100V line operation with easy power tap selection through a terminal block
- Superbly engineered for simple and safe installation
- Ideal for **offices... Restaurants... Hospitals... Shopping Malls... Gymnasiums...**

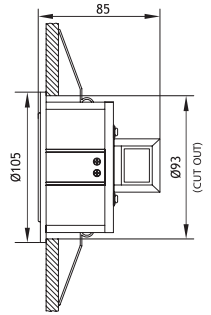

CS-5061T

High quality flush mount ceiling speaker with stylish grille and frame, which integrates wonderfully well with all interiors. Clear and clean sound for speech and music.

- 12.7 cm (5") Full Range Speaker, 6W/100V.
- Beautiful powder coated aluminium mesh grille and moulded plastic frame.
- 100V line operation with easy power tap selection through a terminal block.
- Superbly engineered for simple and safe installations.
- Ideal for **Offices... Restaurants... Hospitals... Shopping Malls... Hotels... Gymnasiums...**

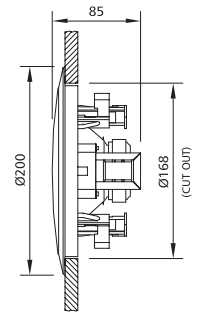

CS-6081T

High quality flush mount ceiling speaker with an elegant grill and frame, which integrates wonderfully well with all interiors. Clear and crisp sound for speech and music.

- 15.24 cm (6") Full Range Speaker, 8W/100V.
- Beautiful powder coated aluminium mesh grille and moulded plastic frame.
- Power tap selection on 100V through female receptacle (push fit).
- Superbly engineered for simple and safe installations.
- Ideal for **Offices... Restaurants... Hospitals... Shopping Malls... Hotels... Gymnasiums...**

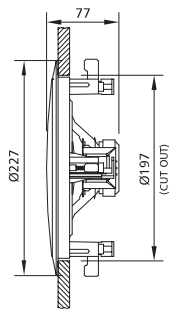

CS-8151T

High quality flush mount ceiling speaker with attractive grill and frame, which integrates very well with all interiors. Outstanding sound quality.

- 20.32 cm (8") Dual Cone Full Range Speaker, 15W/100V.
- High fidelity and excellent frequency response.
- 100V line operation with easy power tap selection through a terminal block.
- Superbly engineered for simple and safe installations.
- CS-8151T is a right choice for **HIGH CEILING**S.
- Ideal for **Offices... Restaurants... Hotels... Hospitals... Shopping Malls... Gymnasiums...**

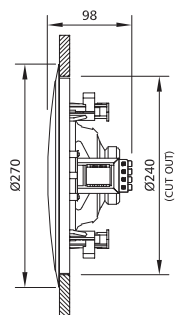

SPECIFICATIONS	CS-3061T	CS-5061T	CS-6081T	CS-8151T
INPUT POWER	6W RMS	6W RMS	8W RMS	15W RMS
POWER TAPS ON 100V	6/3/1.5W	6/3/1.5W	8/4/2W	15/10/5W
IMPEDANCE	1.6k/3.3k/6.6kΩ	1.6k/3.3k/6.6kΩ	1.25k/2.5k/5kΩ	670/1k/2kΩ
FREQUENCY RESPONSE	65-15,000Hz	60-15,000Hz	60-15,000Hz	55-16,000Hz
SPL at 1kHz (1W/1m)	88dB	92dB	92dB	93dB
DIMENSIONS	Ø105 × H85 mm	Ø200 × H85 mm	Ø227 × H77 mm	Ø270 × H98 mm
WEIGHT	410g	750g	780g	1.40kg



CSX-3081T

Attractive, ultra modern rimless design 8 watts ceiling speaker with excellent sound quality. The elegant, low profile design.

- 7.62 cm (3") Full Range Speaker with power taps of 8/4/2W.
- 8 Watts continuous power handling capacity.
- Easy mounting with spring mounting clamps.
- 100V operation with easy selection of power taps.
- Ideal for Offices... Restaurants... Hotels... Hospitals... Shopping Malls... Gymnasiums...

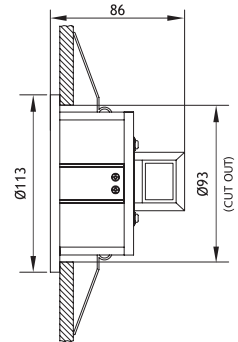

CSX-5081T

Elegant, low profile rimless ceiling speaker with clear, highly intelligible sound. Low profile appearance.

- 12.7 cm (5") Full Range Speaker with power taps of 8/4/2W.
- 8 Watts continuous power handling capacity
- Easy mounting with spring loaded wing clamps.
- 100V operation with easy selection of power taps through a terminal block.
- Ideal for Offices... Restaurants... Hotels... Hospitals... Shopping Malls... Gymnasiums...

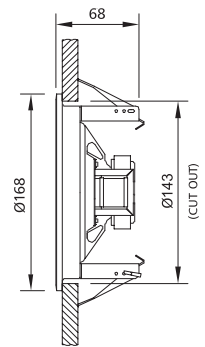

CSX-6101T

Ceiling speaker with an elegant, aesthetically pleasing rimless design. Excellent sound quality combined with an ultra-modern low profile appearance makes this ideally suited for high-end offices, restaurants, bars, malls etc.

- 15.24 cm (6") Full Range Speaker with power taps of 10/5/2.5W.
- 10 Watts continuous power handling capacity.
- Easy mounting with spring loaded wing clamps.
- 100V operation with easy selection of power taps through a terminal block.
- Ideal for Offices... Restaurants... Hotels... Hospitals... Shopping Malls... Gymnasiums.....

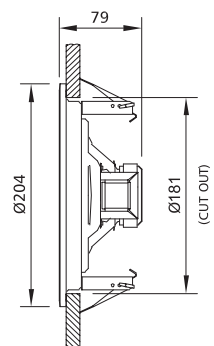

SPECIFICATIONS	CSX-3081T	CSX-5081T	CSX-6101T
INPUT POWER	8W RMS	8W RMS	10W RMS
POWER TAPS ON 100V	8/4/2W	8/4/2W	10/5/2.5W
IMPEDANCE	1.25k/2.5k/5kΩ	1.25k/2.5k/5kΩ	1k/2k/4kΩ
FREQUENCY RESPONSE	65-15,000Hz	80-15,000Hz	60-15,000Hz
SPL at 1kHz (1W/1m)	88dB	92dB	92dB
DIMENSIONS	Ø113 × H86 mm	Ø168 × H68 mm	Ø204 × H79 mm
WEIGHT	450g	700g	910g





2
WAY

CSD-5201T

High power 2-way flush mount ceiling speaker for excellent reproduction of both speech and music. Wide frequency response and adjustable tweeter for optimum directivity.

- Operates on 100V line with power taps of 20/10/5W.
- Moulded plastic frame with metal mesh grille.
- Tweeter can be tilted at an angle to focus clear, intelligible sound in the desired direction.
- 12.7 cm (5") woofer and adjustable 2.54 cm (1") tweeter.
- 100V line operation with easy power tap selection through a terminal block.
- Ideal for **Hotels**... **Office Buildings**... **Restaurants**... **Hospitals**... **Shopping Malls**... **Department Stores**... **Cinemas**... **Gyms**...

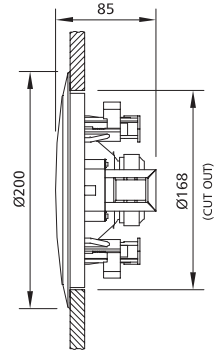

2
WAY

CSD-6303T

High power 2-way flush mount ceiling speaker for excellent reproduction of both speech and music. Wide frequency response and adjustable tweeter for optimum directivity.

- Operates on 100V line with power taps of 30/15/7.5W.
- Moulded plastic frame with metal mesh grille.
- Tweeter can be tilted at an angle to focus clear, intelligible sound in the desired direction.
- 15.24 cm (6") woofer and adjustable 2.54 cm (1") tweeter.
- 100V line operation with easy power tap selection through a terminal block.
- Ideal for **Hotels**... **Office Buildings**... **Restaurants**... **Hospitals**... **Shopping Malls**... **Department Stores**... **Cinemas**... **Gyms**...

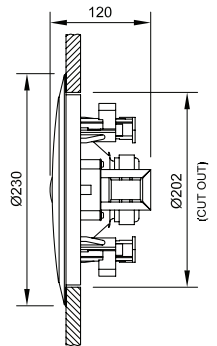

2
WAY

CSD-8401T

High power 2-way flush mount ceiling speaker for excellent reproduction of both speech and music. Adjustable tweeter enables high frequencies to be directed wherever they are most required.

- Operates on 100V line with power taps of 40/20/10W.
- Moulded plastic frame with metal mesh grille.
- Tweeter can be tilted at an angle to focus clear, intelligible sound in the desired direction.
- 20.32 cm (8") woofer and adjustable 2.54 cm (1") tweeter.
- 100V line operation with easy power tap selection through a terminal block.
- Ideal for **Hotels**... **Office Buildings**... **Restaurants**... **Hospitals**... **Shopping Malls**... **Department Stores**... **Cinemas**... **Gyms**...

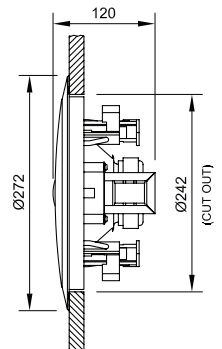

SPECIFICATIONS	CSD-5201T	CSD-6303T	CSD-8401T
INPUT POWER	20W RMS	30W RMS	40W RMS
POWER TAPS ON 100V	20/10/5W	30/15/7.5W	40/20/10W
IMPEDANCE	500/1k/2kΩ	330/670/1.33kΩ	250/500/1kΩ
FREQUENCY RESPONSE	90-18,000Hz	90-18,000Hz	90-18,000Hz
SPL at 1kHz (1W/1m)	91dB	92dB	93dB
SPEAKER	Woofer 127 mm (5") Tweeter 25 mm (1")	Woofer 150 mm (6") Tweeter 25 mm (1")	Woofer 203 mm (8") Tweeter 25 mm (1")
DIMENSIONS	Ø200 × H85 mm	Ø230 × H120 mm	Ø272 × H120 mm
WEIGHT	1.36kg	1.65kg	2.10kg



WSX-551T

High quality, compact and aesthetically designed wall mounting box speaker to suit interiors as in Schools, Offices, BPOs, Hospitals, Banks, Restaurants, Showrooms and Hotels. Clear and clean sound for speech and music.

- 12.7 cm (5") Full Range Wall Speaker in elegant white ABS cabinet, 5W/100V.
- Power tap selection on 100V through female receptacle (push fit).
- Key hole for easy mounting.
- Screw mounting provided from front to make it vandal-proof.

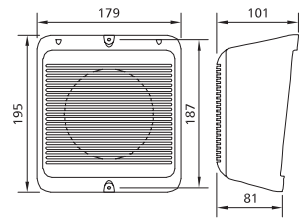

WSX-681T

Superior quality and attractive housing of wall mounting box speaker to suit interiors as in Schools, Offices, BPOs, Hospitals, Banks, Restaurants, Showrooms and Hotels.

- Clear & clean sound for speech and music.
- Elegant plastic cabinet in white colour.
- 15.24cm (6") Full Range Wall Speaker, 8W/100V
- Power tap selection on 100V through female receptacle (push-fit).
- Key hole for easy wall mounting.
- Holes provided on the cabinet for mounting with screws to make it vandal proof.
- Ideal for use in Schools, Offices, BPOs, Hospitals, Banks, Restaurants & Showrooms.

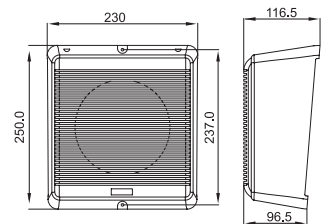

WSX-684T

Superior quality and attractive housing of wall mounting box speaker to suit interiors as in Schools, Offices, BPOs, Hospitals, Banks, Restaurants, Showrooms and Hotels.

- Clear & clean sound for speech and music.
- Elegant plastic cabinet in white colour.
- 15.24cm (6") Full Range Wall Speaker, 8W/100V
- Facility to select four taps & ON OFF position, through an external rotary switch knob.
- Key hole for easy wall mounting.
- Holes provided on the cabinet for mounting with screws to make it vandal proof.
- Ideal for use in Schools, Offices, BPOs, Hospitals, Banks, Restaurants & Showrooms.

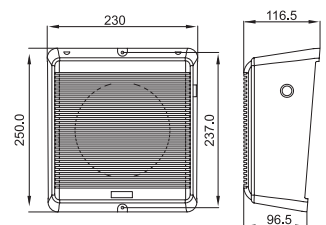

SPECIFICATIONS	WSX-551T	WSX-681T	WSX-684T
POWER RATING	5W RMS/7.5W Max.	8W RMS/12W Max.	8W RMS/12W Max.
POWER TAPS ON 100V	5/2.5/1.25W	8/4/2W	8/4/2/1W
IMPEDANCE	2k/4k/8kΩ	1.25k/2.5k/5kΩ	1.25k/2.5k/5k/10kΩ
FREQUENCY RESPONSE	80-15,000Hz	60-15,000Hz	60-15,000Hz
SPL at 1kHz (1W/1m)	92dB	92dB	92dB
DIMENSIONS	W179 × H195 × D101 mm	W230 × H250 × D115 mm	W230 × H250 × D115 mm
WEIGHT	740g	1.15kg	1.30kg





WS-661TM/WS-664TM

High quality ABS wall mounting box speakers with modern design and better aesthetics. Suitable for indoors; speech & background music. For Schools, Offices, BPOs, Hospitals, Banks, Restaurants, Showrooms and Hotels.

- 15.24 cm (6") Full Range Speaker, 6W/100V.
- Key holes for easy wall mounting.
- Power tap selection on 100V through female receptacle (push fit) in WS-661TM.
- WS-664TM has an additional rotary switch for multiple power tap selection.

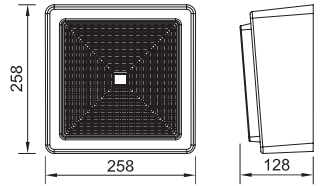

WS-6255TM

Attractive design and high power ABS wall mounting box speaker in grey colour for indoor public address and background music in locations of high ambient noise. Ideal for Schools, Hospitals, Canteens, Colleges, Railway Platforms and Hostels.

- 16.51 cm (6.5") Full Range Speaker provides clear and clean sound for both speech and music; 25W/100V.
- Key holes for easy wall mounting.
- Power tap selection on 100V through terminal strip.

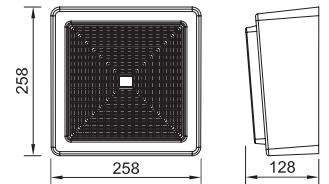

BS-6082T/BS-6083T

Stylish & rugged metal box speaker for a variety of speech & background music applications such as Railway Coaches, Industrial Establishments, Schools, Warehouses, Public Buildings etc. Powder coated metal enclosure.

- Vandal-proof metal cabinet in ivory colour.
- 15.24 cm (6") Full Range Speaker, 8W/100V.
- Key holes for easy wall mounting.
- BS-6082T is wall mount version.
- BS-6083T is for both wall & ceiling mounting.
- Easy power tap selection through terminal strip.

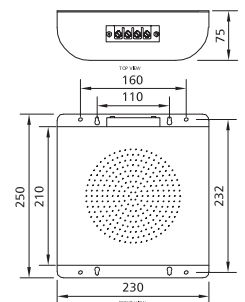

SPECIFICATIONS	WS-661TM/WS-664TM	WS-6255TM	BS-6082T/BS-6083T
POWER RATING	6W RMS/9W Max.	25W RMS/37.5W Max.	8W RMS/12W Max.
POWER TAPS ON 100V	6/3/1.5W	25/15/10/5W	8/4/2W
IMPEDANCE	1.6k/3.3k/6.6kΩ	400/670 /1k/2kΩ	1.25k/2.5k/5kΩ
FREQUENCY RESPONSE	60-15,000Hz	120-15,000Hz	60-15,000Hz
SPL at 1kHz (1W/1m)	92dB	94dB	92dB
DIMENSIONS	W258 × H258 × D128 mm	W258 × H258 × D128 mm	W230 × H230 × D75 mm/ W230 × H250 × D75 mm
WEIGHT	1.18kg/1.25kg	1.69kg	1.80kg



IMPRESS 75T 75 WATTS



- High performance 2-Way PA Wall Speaker in modern & attractive plastic housing.
- Superb tonal quality provides high fidelity with uniform coverage.
- Comprises of a Water Resistant PP coated cone Woofer, a Titanium Dome Tweeter and a 2-way Crossover Network.
- Power taps of 30W, 15W & 7.5W are available on 100V line along with low impedance 8Ω tap.
- Easy power tap selection through a rotary switch knob.
- Unique mounting system provides 90° horizontal and 45° vertical rotation of the wall speaker.
- Ideal for various indoor and outdoor (under eaves) applications in **Airports, Banks, Schools, Hotels, Restaurants, Lounges, Hospitals, Showrooms etc.**

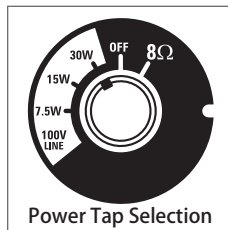

IMPRESS 100T 100 WATTS



- High performance 2-Way PA Wall Speaker in modern & attractive plastic housing.
- Superb tonal quality provides high fidelity with uniform coverage.
- Comprises of a Water Resistant PP coated cone Woofer, a Titanium Dome Tweeter and a 2-way Crossover Network.
- Power taps of 60W, 30W & 15W are available on 100V line along with low impedance 8Ω tap.
- Easy power tap selection through a rotary switch knob.
- Unique mounting system provides 90° horizontal and 45° vertical rotation of the wall speaker.
- Ideal for various indoor and outdoor (under eaves) applications in **Airports, Banks, Schools, Hotels, Restaurants, Lounges, Hospitals, Showrooms etc.**

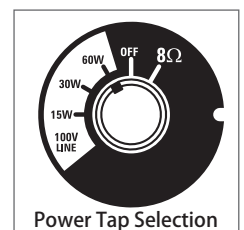

SPECIFICATIONS	IMPRESS 75T	IMPRESS 100T
POWER HANDLING	75W RMS / 115W Max.	100W RMS / 150W Max.
NOMINAL IMPEDANCE	8Ω	8Ω
TRANSFORMER POWER TAPS	30/15/7.5W	60/30/15W
FREQUENCY RESPONSE	60-20,000Hz	50-20,000Hz
SPL at 1kHz (1W/1m)	90dB	90dB
MAX SPL	110dB	112dB
COVERAGE ANGLE (HxV)	90° × 90°	90° × 90°
LF SPEAKER	133 mm (5.25")	203 mm (8.0")
HF TWEETER	20 mm (0.75")	25 mm (1.0")
CONNECTORS	Removable locking 4-pin connector (Euroblock) for connection to additional speakers or to the binding post	Removable locking 4-pin connector (Euroblock) for connection to additional speakers or to the binding post
DIMENSIONS	W180 × H255 × D163mm	W250 × H390 × D236mm
WEIGHT	3.23kg	6.15kg



2-Way Compact Wall Speakers



ASX-312B/312BT ASX-312W/312WT 30 WATTS

- High fidelity 2-Way PA Wall Speaker in compact & attractive Black or White plastic housing. The suffix B & BT denote Black cabinet, and W & WT denote White cabinet.
- Comprises of a Water Resistant PP coated cone Woofer, a Titanium Dome Tweeter and a 2-way Crossover Network.
- ASX-312B and ASX-312W are low impedance 8Ω speakers.
- ASX-312BT and ASX-312WT are meant for use on 100V line with power taps of 30W, 20W, 15W, 10W & 5W.
- Easy power tap selection through a slotted rotary switch knob at the rear.
- 'U' type bracket for convenient & firm mounting of the wall speaker.
- Ideal for various background music & general PA application.

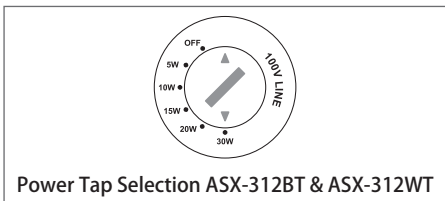

ASX-612B/612BT ASX-612W/612WT 60 WATTS

- High fidelity 2-Way PA Wall Speaker in compact & attractive Black or White plastic housing. The suffix B & BT denote Black cabinet, and W & WT denote White cabinet.
- Comprises of a Water Resistant PP coated cone Woofer, a Titanium Dome Tweeter and a 2-way Crossover Network.
- ASX-612B and ASX-612W are low impedance 8Ω speakers.
- ASX-612BT and ASX-612WT are meant for use on 100V line with power taps of 60W, 40W, 30W, 20W & 10W.
- Easy power tap selection through a slotted rotary switch knob at the rear.
- 'U' type bracket for convenient & firm mounting of the wall speaker.
- Ideal for various background music & general PA application.

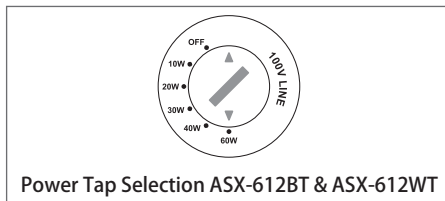

ASX-912B/912BT ASX-912W/912WT 90 WATTS

- High fidelity 2-Way PA Wall Speaker in compact & attractive Black or White plastic housing. The suffix B & BT denote Black cabinet, and W & WT denote White cabinet.
- Comprises of a Water Resistant PP coated cone Woofer, a Titanium Dome Tweeter and a 2-way Crossover Network.
- ASX-912B and ASX-912W are low impedance 8Ω speakers.
- ASX-912BT and ASX-912WT are meant for use on 100V line with power taps of 90W, 60W, 30W & 15W.
- Easy power tap selection through a slotted rotary switch knob at the rear.
- 'U' type bracket for convenient & firm mounting of the wall speaker.
- Ideal for various background music & general PA application.

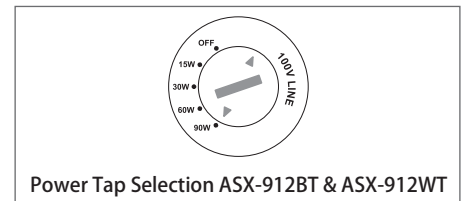

■ Black Cabinet (B & BT) ■ White Cabinet (W & WT)

SPECIFICATIONS	ASX-312B/312BT	ASX-612B/612BT	ASX-912B/912BT
POWER RATING	30W RMS/45W Max.	60W RMS/90W Max.	90W RMS / 135W Max.
POWER TAPS	30W, 30/20/15/10/5W	60W, 60/40/30/20/10W	90W, 90/60/30/15W
IMPEDANCE/VOLTAGE	8Ω / 100V	8Ω / 100V	8Ω / 100V
FREQUENCY RESPONSE	75-20,000Hz	50-20,000Hz	55-20,000Hz
SPL at 1kHz (1W/1m)	87dB	87dB	90dB
SPEAKER	Woofer 100 mm (4"), Tweeter 25 mm (1")	Woofer 165 mm (6½"), Tweeter 25 mm (1")	Woofer 203 mm (8"), Tweeter 25 mm (1")
DIMENSIONS	W180 × H248 × D140 mm	W215 × H310 × D175 mm	W270 × H378 × D200 mm
WEIGHT	2.45kg/2.92kg	3.22kg/3.80kg	4.97kg/6.30kg



PS-300TM 10 WATTS

- High fidelity 2-Way, 100V multi-purpose PA Wall Speaker.
- 100V, Power taps of 6W, 3W & 1.5W
- Power taps can be selected through a rotary switch.
- Facility to use as 8 ohms Low Impedance Speaker available.
- Movable mounting bracket supplied, can be mounted in vertical or horizontal positions.

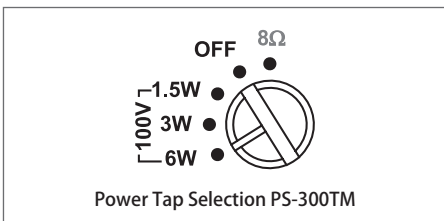

PS-400TM 16 WATTS

- High fidelity 2-Way, 100V multi-purpose PA Wall Speaker.
- 100V Power taps of 16W, 8W & 4W.
- Power taps can be selected through a rotary switch.
- Facility to use as 8 ohms Low Impedance Speaker available.
- Weather Resistant Speaker.
- Movable mounting bracket supplied, can be mounted in vertical or horizontal positions.

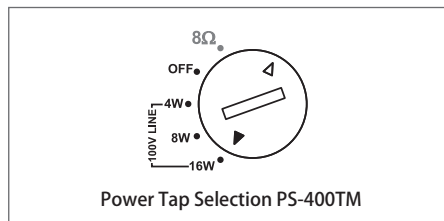

PS-500TM 32 WATTS

- High fidelity 2-Way, 100V multi-purpose PA Wall Speaker.
- 100V, Power taps of 32W, 16W, 8W.
- Facility to use as 8 ohms Low Impedance Speaker available.
- Power Taps can be selected through an easily accessible rotary switch.
- Weather Resistant Speaker.
- Movable mounting bracket supplied, can be mounted in vertical or horizontal positions.

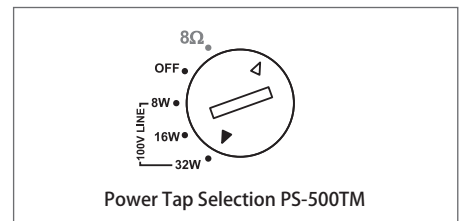

COMMON FEATURES

- High Fidelity sound for music.
- Speaker consists of woofer & dome tweeter.
- Elegant plastic cabinet in White colour and also available in Black colour cabinet.
- Ideal for background music in offices, banks, restaurants, showrooms etc.

SPECIFICATIONS	PS-300TM	PS-400TM	PS-500TM
POWER RATING	10W RMS / 15W Max.	16W RMS / 24W Max.	32W RMS / 48W Max.
RATED VOLTAGE	100V	100V	100V
POWER TAPS ON 100V	6/3/1.5W	16/8/4W	32/16/8W
LOW IMPEDANCE	8Ω	8Ω	8Ω
FREQUENCY RESPONSE	150-20,000Hz	85-20,000Hz	80-20,000Hz
SPL at 1kHz (1W/1m)	86dB	86dB	87dB
SPEAKER	Woofer 75 mm (3"), Tweeter 31 mm (1.22") dome	Woofer 93 mm (3.6"), Tweeter 47 mm (1.85") dome	Woofer 130 mm (5.25"), Tweeter 47 mm (1.85") dome
DIMENSIONS	W105 × H161 × D119mm	W133 × H209 × D130 mm	W162 × H256 × D165 mm
WEIGHT	1.04kg	1.60kg	2.49kg



Special Purpose Speakers

PA Sound Projector



SP-5251T



Compact & elegant controlled directivity sound projector in aesthetically beautiful white plastic cabinet. Water resistant speaker used in SP-5251T is suitable for outdoor applications also.

- 11.43 cm (4.5") Full Range Speaker, 25W/100V.
- Easy power tap selection through a rotary switch.
- 'U' type powder coated mounting bracket
- Ideal for **Factories... Hospitals... Hotels... Schools... Railway Platforms...**

PA Dual Sound Projector



SP-6305TD



Compact & weather resistant bi-directional projection speaker in aesthetically pleasing white plastic cabinet. Creates uniform ambience of sound in a wider area from a single sound source.

- IP44 degree of dust and water protection.
- 2 × 16.51 cm (6.5") Full Range water resistant speakers facing in opposite direction, 30W/100V.
- 'U' type mounting bracket for easy & trouble free installation.
- Ideal for **Railway Platforms... Factories... Parking Lots... School Corridors... Theme Parks...**

SPECIFICATIONS	SP-5251T	SP-6305TD
INPUT POWER	25W RMS	30W RMS
POWER TAPS ON 100V	25/20/15/10/5W	30/20/10/5W
IMPEDANCE	400/500/670/1k/2kΩ	330/500/1k/2kΩ
FREQUENCY RESPONSE	120-15,000Hz	120-15,000Hz
SPL at 1kHz (1W/1m)	93dB	94dB
DIMENSIONS	Ø183 × H215 mm	Ø175 × H256 mm
WEIGHT	2.10kg	2.60kg

Speaker Volume Controllers

AT-06/AT-20/AT-40

Speaker Volume Control

- Attractive, aesthetically pleasing white plastic housing.
- Simple to install against walls, partitions and panels, even after the wiring is complete.
- Compatible with all Ahuja wall and ceiling speakers with 100V line matching transformer.
- Reliable, high wattage rotary switch (in AT-40 and AT-20) has 11 selectable positions: Max, 9 attenuated positions (in 3 dB steps) & OFF.
- AT-06 has a reliable rotary switch with 5 selectable positions: Max, 3 attenuated positions (in 3dB steps) & OFF.
- Suitable for connection to speaker or speakers with RMS power rating up to 40 Watts (for AT-40), 20 Watts (for AT-20) and 6 Watts (for AT-06).
- Ideal for hotels, office cabins, showrooms, greenrooms, etc.



SPECIFICATIONS	AT-06	AT-20	AT-40
RATED POWER	6W RMS	20W RMS	40W RMS
INPUT VOLTAGE	100V	100V	100V
OUTPUT POSITIONS	Max, 3 attenuation positions in 3dB steps (-3dB to -9dB) and OFF	Max, 9 attenuation positions in 3dB steps (-3dB to -27dB) and OFF	Max, 9 attenuation positions in 3dB steps (-3dB to -9dB) and OFF
DIMENSIONS	W87 × H87 × D78 mm	W87 × H87 × D78 mm	W87 × H87 × D78 mm
WEIGHT	150g	250g	250g

2-Way Outdoor Speaker



OSX-666T 60 WATTS



- Reliable IP-66 rated, weather resistant plastic cabinet wall speaker with outstanding sound clarity.
- Comprises of a Polypropylene Cone Woofer, a Titanium Silk Dome Tweeter and a Crossover Network.
- Operates on 100V line, or on direct 8Ω impedance,selectable through a slotted rotary switch knob at the rear which is accessible after removing the terminal cover.
- Front grill is made of perforated aluminium sheet which provides rust-free service in various weather conditions.
- 'U' type metal bracket for firm mounting and optimum positioning of the wall speaker.
- Bidirectional key holes in the mounting bracket are available for fixing the speaker horizontally or vertically.
- Use of Cable Gland, supplied along with, is essential for ensuring the IP rating of this speaker.
- Suitable for various indoor and outdoor applications.

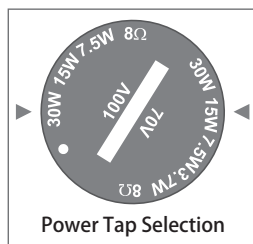

OSX-999T 90 WATTS



- Reliable IP-66 rated, weather resistant plastic cabinet wall speaker with outstanding sound clarity.
- Comprises of a Polypropylene Cone Woofer, a Titanium Silk Dome Tweeter and a Crossover Network.
- Operates on 100V line, or on direct 8Ω impedance,selectable through a slotted rotary switch knob at the rear which is accessible after removing the terminal cover.
- Front grill is made of perforated aluminium sheet which provides rust-free service in various weather conditions.
- 'U' type metal bracket for firm mounting and optimum positioning of the wall speaker.
- Bidirectional key holes in the mounting bracket are available for fixing the speaker horizontally or vertically.
- Use of Cable Gland, supplied along with, is essential for ensuring the IP rating of this speaker.
- Suitable for various indoor and outdoor applications.

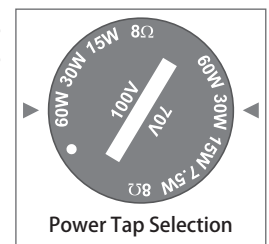

SPECIFICATIONS	OSX-666T	OSX-999T
POWER RATING	60W RMS / 90W Max.	90W RMS / 135W Max.
IMPEDANCE	8Ω	8Ω
POWER TAPS ON 100V	30/15/7.5W	60/30/15W
FREQUENCY RESPONSE	95-20,000Hz	80-20,000Hz
SPL at 1kHz (1W/1m)	87dB	87dB
SPEAKER	Woofer 165 mm (6.5"), Tweeter 25 mm (1.0")	Woofer 203 mm (8"), Tweeter 25 mm (1.0")
DIMENSIONS	W205 × H330 × D199 mm	W251 × H398 × D232 mm
WEIGHT	3.10kg	4.30kg



Special Purpose Speakers

Garden Speaker



GSX-630T 30 WATTS



- Rugged & compact 2-way green garden speaker which blends with the outdoor garden environment.
- Fitted with an efficient 2-way speaker system which has wide response suitable for both music and speech applications.
- 15.24 cm (6") PP Cone LF speaker and 2.54cm (1") HF speaker.
- IP 66 rating is provided against foreign particles such as dust and jets of water, thus making them ideal for outdoor use.
- Rugged and stable construction for mounting on the concrete & wooden surfaces.
- Easy power tap selection on 100V line through different colour wires.
- Ideal for Gardens... Hotels... Farm Houses... Theme Parks... Lawns of Religious Places... Historical Monuments...

SPECIFICATIONS	GSX-630T	LSX-930T
INPUT POWER	30W RMS / 45W Max.	30W RMS / 45W Max.
POWER TAPS ON 100V	30/15/7.5W	30/15/7.5W
LOW IMPEDANCE	—	8Ω
FREQUENCY RESPONSE	80-20,000Hz	70-20,000Hz
SPL at 1kHz (1W/1m)	90dB	95dB
DIMENSIONS	∅325 × H335 mm	W330 × H552 × D270 mm
WEIGHT	3.00kg	3.50kg

Landscape Speaker



LSX-930T 30 WATTS



- Strong & beautiful 2-way landscape speaker is designed to merge harmoniously with any landscaped area.
- Fitted with an efficient 2-way speaker system which provides high fidelity sound and horizontal dispersion pattern of 360 degrees.
- 16.5 cm (6.5") PP Cone LF speaker and 2.54cm (1") HF speaker.
- IP 66 rating is provided against foreign particles such as dust and jets of water, thus making them ideal for outdoor use.
- Designed to be mounted on or in the ground.
- Power taps on 100V line & 8Ω tap can be selected through a rotary switch.
- Ideal for Gardens... Hotels... Farm Houses... Theme Parks... Lawns of Religious Places... Residential Areas... Historical Monuments...

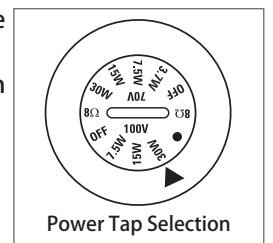

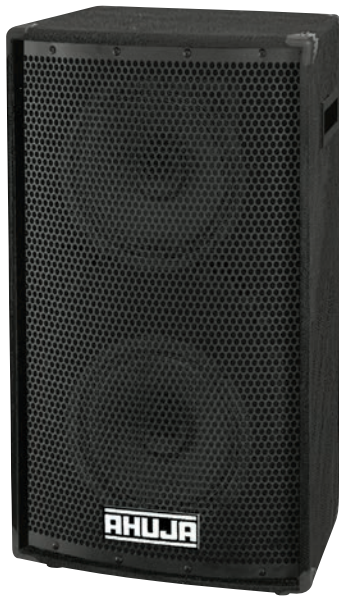

SRX-50DX/50XT 50 WATTS

A compact general purpose Loudspeaker column using two Full Range Dual Cone 20.32 cm (8") speakers, reproducing a clean undistorted sound for both speech and music. The system is housed in a Rugged Closed Box Enclosure made of 12 mm medium density fibre board, and is carpet covered. SRX-50DX has nominal impedance of 16Ω, SRX-50XT operates on 100V line with three power taps selectable through a rotary switch.



SRX-120®DXM 100 WATTS

An elegant and reliable Loudspeaker comprising of a single 30.48 cm (12") Full Range Dual Cone speaker and a Piezo Horn Tweeter. The system is capable of handling 100W continuous power with undistorted response and is ideal for small PA applications. The speakers are housed in a trapezoidal closed box enclosure made of 18 mm board, and carpet covered. Fully protected by front grille. Ergonomically designed handles for easy portability. Stand mount adaptor is provided at the bottom.



SRX-200 200 WATTS

Professional 2-Way PA Loudspeaker to provide superb LF Response, High Efficiency and Long Throw with Excellent Sound Intelligibility. It consists of one 30.48 cm (12") Full Range Dual Cone Speaker and a Piezo Horn Tweeter. The system is housed in an acoustically treated Bass Reflex enclosure made of 18 mm board, and carpet covered. Stand mount adaptor is provided at the bottom.

SPECIFICATIONS	SRX-50DX	SRX-50XT	SRX-120®DXM	SRX-200
POWER RATING	50W Max.	50W Max.	100W RMS/200W Programme	200W RMS/400W Programme
POWER TAPS	—	30/20/10W at 100V	—	—
CONFIGURATION	One Way	One Way	Two Way	Two Way
FREQUENCY RESPONSE	55-16,000Hz	55-16,000Hz	55-20,000Hz	50-20,000Hz
LOW FREQUENCY SPEAKER	2 × 203.2 mm (8"), Ø19.05 mm (0.75") Voice Coil	2 × 203.2 mm (8"), Ø19.05 mm (0.75") Voice Coil	1 × 304.8 mm (12"), Ø38.1 mm (1.5") Voice Coil	1 × 304.8 mm (12"), Ø50.8 mm (2.0") Voice Coil
HIGH FREQUENCY UNIT	—	—	1 × Piezo Horn Tweeter	1 × Piezo Horn Tweeter
	—	—	50.8 mm (2") × 127 mm (5")	76.2 mm (3") × 152.4 mm (6")
SPL at (1W/1m)	96dB	96dB	97 dB	97dB
MAX. RATED SPL	113dB	113dB	117 dB	120dB
NOMINAL IMPEDANCE	16 Ω	333/500/1kΩ	8 Ω	8 Ω
PORT	Sealed Enclosure	Sealed Enclosure	Sealed Enclosure	Free Flow Flared
INPUT CONNECTORS	Two nos. of Terminal Strip in parallel	Through 2 Core Cable	1/4" Phone Jack + Terminal Strip	1/4" Phone Jack + Terminal Strip
DIMENSIONS	W325 × H585 × D240 mm	W325 × H605 × D240 mm	W410 × H530 × D380 mm	W410 × H600 × D430mm
WEIGHT	9.20kg	9.60kg	15.40kg	22.30kg





SRX-220® 200 WATTS

Professional 2-Way Loudspeaker with high efficiency, long throw & clean undistorted sound for both speech & music. It consists of one 38.1 cm (15") Full Range Dual Cone Speaker and a Piezo Horn Tweeter. The system is housed in an acoustically treated Bass Reflex Trapezoidal enclosure made of 18 mm board, and carpet covered. Stand mount adaptor is provided at the bottom.



SRX-250®DXM 200 WATTS

An aesthetically superior Loudspeaker that combines two 30.48 cm (12") Full Range Dual Cone speakers and a Piezo Horn Tweeter. It delivers the fidelity of sound and the column effect for sound coverage demanded in sound reinforcement and PA applications. The system is housed in a Rugged Trapezoidal Bass Reflex Enclosure made of 18 mm board, and Carpet covered. Fully protected by front grille. Ergonomically designed handles for easy portability. Stand mount adaptor is provided at the bottom.



SRX-260 200 WATTS

Professional 2-Way Loudspeaker System with two 30.48 cm (12") Full Range Dual Cone Speakers and a Piezo Horn Tweeter. It delivers clear and undistorted sound. It provides column effect for sound coverage demanded in sound reinforcement and PA applications. The system is housed in a Rugged Trapezoidal Bass Reflex painted enclosure made of 18 mm board and strong front grille. Ergonomically designed handles for easy portability. Stand mount adaptor is provided at the bottom.

SPECIFICATIONS	SRX-220	SRX-250®DXM	SRX-260
POWER RATING	200W RMS/400W Programme	200W RMS/400W Programme	200W RMS/400W Programme
CONFIGURATION	Two Way	Two Way	Two Way
FREQUENCY RESPONSE	50-20,000Hz	55-20,000Hz	55-20,000Hz
LOW FREQUENCY SPEAKER	1 × 381 mm (15"), Ø50.8 mm (2.0") Voice Coil	2 × 304.8 mm (12"), Ø38.1 mm (1.5") Voice Coil	2 × 304.8 mm (12"), Ø38.1 mm (1.5") Voice Coil
HIGH FREQUENCY UNIT	1 × Piezo Horn Tweeter	1 × Piezo Horn Tweeter	1 × Piezo Horn Tweeter
	76.2 mm (3") × 152.4 mm (6")	76.2 mm (3") × 152.4 mm (6")	76.2 mm (3") × 152.4 mm (6")
SPL at (1W/1m)	98dB	100dB	100dB
MAX. RATED SPL	121dB	123dB	123dB
NOMINAL IMPEDANCE	8Ω	8Ω	8Ω
PORT	Free Flow Flared	Free Flow Flared	Free Flow Flared
INPUT CONNECTORS	1/4" Phone Jack + Terminal Strip	1/4" Phone Jack + Terminal strip	1/4" Phone Jack + Terminal strip
DIMENSIONS	W490 × H680 × D415mm	W410 × H860 × D370 mm	W410 × H860 × D370 mm
WEIGHT	26.00kg	25.00kg	25.00kg



SRX-440 400 WATTS

High power, high efficiency professional Loudspeaker with well-balanced wide-spectrum sound. Consists of two 30.48 cm (12") Dual Cone Speakers and a Piezo Horn Tweeter fitted in a rugged bass reflex carpet covered enclosure. The cabinet has been fitted with heavy-duty handles to allow ease of transportation and a strong steel grille for speaker protection. A stand adapter is provided at the bottom for pole mounting. Ideal for DJs, variety music programmes and general PA applications.



SRX-500® 400 WATTS

Professional 2-Way Loudspeaker with long throw and unmatched intelligibility of sound. It consists of two 38.1cm (15") full range dual cone speakers and a High frequency compression driver. The speaker system is housed in an acoustically treated Bass Reflex Trapezoidal carpet covered enclosure. Fitted with heavy-duty handles and a strong steel grille. Ideal for both indoor and outdoor sound reinforcement applications. Specially designed for Auditoriums and DJs.



SRX-510 400 WATTS

Professional 2-Way Loudspeaker with long throw and unmatched intelligibility of sound. It consists of two 38.1cm (15") full range dual cone speakers and a High frequency compression driver. The speaker system is housed in an acoustically treated Bass Reflex Trapezoidal painted enclosure. Fitted with heavy-duty handles and a strong steel grille. Ideal for both indoor and outdoor sound reinforcement applications. Specially designed for Auditoriums and DJs.

SPECIFICATIONS	SRX-440	SRX-500®	SRX-510
POWER RATING	400W RMS/800W Programme	400W RMS/800W Programme	400W RMS/800W Programme
CONFIGURATION	Two Way	Two Way	Two Way
FREQUENCY RESPONSE	50-20,000Hz	50-20,000Hz	50-20,000Hz
LOW FREQUENCY SPEAKER	2 × 304.8 mm (12"), Ø50.8 mm (2.0") Voice Coil	2 × 381 mm (15"), Ø50.8 mm (2.0") Voice Coil	2 × 381 mm (15"), Ø50.8 (2.0") Voice Coil
HIGH FREQUENCY UNIT	1 × Piezo Horn Tweeter 76.2 mm (3") × 152.4 mm (6")	1 × Dynamic Horn, 101.6 mm (4") × 254 mm (10")	1 × Dynamic Horn, 101.6 mm (4") × 254 mm (10")
SPL at (1W/1m)	100dB	101dB	101dB
MAX. RATED SPL	126dB	127dB	127dB
NOMINAL IMPEDANCE	8Ω	8Ω	8Ω
CROSSOVER FREQUENCY	—	6kHz	6kHz
PORT	Free Flow Flared	Free Flow Flared	Free Flow Flared
INPUT CONNECTORS	1/4" Phone Jack + Terminal strip	Speakon + Terminal Strip	Speakon + Terminal Strip
DIMENSIONS	W416 × H930 × D430 mm	W510 × H1135 × D505 mm	W505 × H1125 × D503 mm
WEIGHT	33.50kg	49.50kg	52.00kg





SPX-450 400 WATTS

A high efficiency 400 Watts professional 2-Way PA Loudspeaker has superb low frequency response, long throw and excellent sound intelligibility. Two 30.48 cm (12") high performance LF loudspeakers and a high frequency compression horn driver housed in an acoustically treated bass reflex trapezoidal Carpet covered enclosure. Strong steel grille for speaker protection. Heavy duty metal handles provide ease of mobility and transportation. Ideal for Auditoria... Religious Gatherings... Live Concerts... DJs... etc.



SPX-550 400 WATTS

Elegant and efficient 400 Watts professional 2-Way PA Loudspeaker with superior low frequency response and excellent sound intelligibility. One 38.1 cm (15") high performance LF loudspeaker and a high frequency compression horn driver housed in an acoustically treated bass reflex trapezoidal painted enclosure made of 18 mm Plywood. A Stand Adapter is provided at the bottom for stand mounting. Strong steel grille for speaker protection. Heavy duty metal handles provide ease of mobility and transportation. Ideal for Auditoria... Religious Gatherings... Live Concerts... DJs... etc.

SPECIFICATIONS	SPX-450	SPX-550
POWER RATING	400W RMS/800W Programme	400W RMS/800W Programme
CONFIGURATION	Two Way	Two Way
FREQUENCY RESPONSE	45-20,000Hz	45-18,000Hz
SPEAKER	2 × 304.8 mm (12") LF Speaker	1 × 381 mm (15"), Ø76.2 mm (3") Voice Coil
HIGH FREQUENCY UNIT	Dynamic Horn 101.6 mm (4") × 254 mm (10")	Dynamic Horn 222 mm (8.75") × 280 mm (11")
SPL at (1W/1m)	100dB	98dB
MAX. RATED SPL	124dB	124dB
NOMINAL IMPEDANCE	8Ω	8Ω
CROSSOVER FREQUENCY	4kHz	2kHz
PORT	Free Flow Flared	Free Flow Flared
INPUT CONNECTORS	Speakon + Terminal Strip	2 Nos. of Speakon Socket
DIMENSIONS	W465 × H995 × D405 mm	W460 × H730 × D413mm
WEIGHT	38.80kg	30.00 kg



4x12" 1 WAY 4Ω

SQX-850

800 WATTS

Sturdy & rugged carpet covered bass reflex cabinet built around 4 nos high quality 30.48 cm (12") dual cone speakers. Features high efficiency, high sound pressure level, & unmatched bass. Tuned for optimum performance, and having a high power handling capacity of 800 Watts RMS, this is an ideal cabinet speaker for large gatherings and for use with high power amplifiers.



1x12" 2 WAY 8Ω

SAX-200DX

200 WATTS

Professional 2-Way Loudspeaker consists of one high efficiency 30.48 cm (12") LF speaker and a 2.54 cm (1") HF Compression Driver. The system is housed in a Rugged Bass Reflex Trapezoidal Enclosure made of 18 mm board, and Carpet covered. A Stand Adapter at the bottom for stand mounting is also provided. The trapezoidal enclosure construction assures optimum low frequency performance and smoothness with minimum interference from standing waves and box resonance. The speaker produces high sound pressure levels with accuracy in any environment and thus is ideal for all PA and music performances.



1x15" 3 WAY 8Ω

SAX-300DX

300 WATTS

Professional 3-Way Loudspeaker consisting of one high efficiency, high SPL 38.1 cm (15") LF speaker, a 2.54 cm (1") HF Compression Driver and two Piezo Tweeters, for excellent high frequency response. The system is housed in a Rugged Bass Reflex Trapezoidal Enclosure made of 18 mm board, and Carpet covered. A Stand Adapter is provided at the bottom for stand mounting. The trapezoidal cabinet design assures optimum low frequency performance. An On/Off switch for the piezo speakers is provided to limit extended HF if desired. The speaker is ideal for PA as well as music performances.

SPECIFICATIONS	SQX-850	SAX-200DX	SAX-300DX
POWER RATING	800W RMS/1600W Programme	200W RMS/400W Programme	300W RMS/600W Programme
CONFIGURATION	One Way	Two Way	Three Way
FREQUENCY RESPONSE	50-16,000Hz	45-20,000Hz	40-20,000Hz
LOW FREQUENCY SPEAKER	4 × 304.8 mm (12") Full Range Speaker	1 × 304.8 mm (12"), Ø50.8 mm (2") Voice Coil	1 × 381 mm (15"), Ø76.2 mm (3") Edge Wound Voice coil
HIGH FREQUENCY UNIT	—	Dynamic Horn, 101.6 mm (4") × 254 mm (10")	Dynamic Horn, 101.6 mm (4") × 254 mm (10") + 2 Piezo Tweeters
SPL at (1W/1m)	103dB	97dB	100dB
MAX. RATED SPL	132dB	119dB	125dB
NOMINAL IMPEDANCE	4Ω	8Ω	8Ω
CROSSOVER FREQUENCY	—	4kHz	4kHz
PORT	Free Flow Flared	Free Flow Flared	Free Flow Flared
INPUT CONNECTORS	Speakon + Terminal Strip	1/4" Phone Jack + Terminal Strip	1/4" Phone Jack + Terminal Strip
DIMENSIONS	W755 × H810 × D525 mm	W510 × H655 × D405 mm	W550 × H755 × D425 mm
WEIGHT	55.10kg	25.50kg	33.00kg





SPX-710
600 WATTS

Compact and powerful 600 Watts Professional 2-Way PA Loudspeaker with excellent LF response, exceptional efficiency and unmatched intelligibility of sound. Two 30.48 cm (12") high performance LF loudspeakers and a high power titanium compression horn driver housed in an acoustically treated bass reflex trapezoidal painted enclosure made of 18 mm Plywood. Strong steel grille for speaker protection. Heavy duty metal handles allow ease of mobility and transportation. Suitable for both indoor and outdoor sound reinforcement applications. Ideal for Auditoria... DJs... Live...Concerts... Discos... etc.



SPX-800
700 WATTS

This is 700 Watts Professional 2-Way PA Loudspeaker with excellent LF response, exceptional efficiency, long throw and unmatched intelligibility of sound. Two 38.1 cm (15") high performance LF loudspeakers and a high frequency titanium compression horn driver housed in an acoustically treated bass reflex trapezoidal carpet covered enclosure. Strong steel grille for speaker protection. Heavy duty metal handles allow ease of mobility and transportation. Suitable for both indoor and outdoor sound reinforcement applications. Ideal for Auditoria... DJs... Live... Concerts... Discos... etc.

SPECIFICATIONS	SPX-710	SPX-800
POWER RATING	600W RMS/1200W Programme	700W RMS/1400W Programme
CONFIGURATION	Two Way	Two Way
FREQUENCY RESPONSE	40-20,000Hz	40-20,000Hz
LOW FREQUENCY SPEAKER	2 × 305 mm (12"), Ø76.2 mm (3") Voice coil	2 × 381 mm (15"), Ø76.2 mm (3") Voice coil
HIGH FREQUENCY UNIT	Dynamic Horn 222 mm (8.75") × 280 mm (11")	Dynamic Horn 177.8 mm (7") × 304.8 mm (16")
SPL at (1W/1m)	104dB	103dB
MAX. RATED SPL	131dB	131dB
NOMINAL IMPEDANCE	4Ω	4Ω
CROSSOVER FREQUENCY	4kHz	2kHz
PORT	Free Flow Flared	Free Flow Flared
INPUT CONNECTORS	2 Nos. of Speakon Sockets	2 Nos. of Speakon Sockets
DIMENSIONS	W405 × H1016 × D378 mm	W542 × H1190 × D517 mm
WEIGHT	42.70kg	64.00kg



SPX-810
700 WATTS

Professional 700 Watts 2-Way PA Loudspeaker in attractive painted enclosure made of 18 mm Plywood. Loaded with two highly efficient 38.1 cm (15") low frequency speakers and a reliable high frequency titanium compression horn driver. Acoustically treated bass reflex cabinet is capable of producing excellent low frequency response together with impressive mid and high frequency response. Strong steel grille ensures speaker protection and durability. Heavy duty metal handles allow easy transportation. Ideal for use in a variety of indoor and outdoor sound reinforcement applications like Auditoria, DJs, Live Performances etc.



SPX-1300
1100 WATTS

Outstanding professional 2-Way PA Loudspeaker with 1100 Watts continuous power handling capacity. Two high power 38.1 cm (15") LF loudspeakers and a high frequency titanium compression horn driver give very well defined, prominent lows and brilliant highs. Acoustically treated bass reflex trapezoidal carpet covered cabinet with a strong steel grille ensures protection and durability. Heavy duty metal handles allow ease of mobility and transportation. Ideal for use with high powered amplifiers for large gatherings.

SPECIFICATIONS	SPX-810	SPX-1300
POWER RATING	700W RMS/1400W Programme	1100W RMS/2200W Programme
CONFIGURATION	Two Way	Two Way
FREQUENCY RESPONSE	40-20,000Hz	35-20,000Hz
LOW FREQUENCY SPEAKER	2 × 381 mm (15"), Ø76.2mm (3") Voice coil	2 × 381 mm (15"), Ø101.6 mm (4") Voice coil
HIGH FREQUENCY UNIT	Dynamic Horn 177.8 mm (7") × 406.4 mm (16")	Dynamic Horn 177.8 mm (7") × 406.4 mm (16")
SPL at (1W/1m)	103dB	103dB
MAX. RATED SPL	131dB	133dB
NOMINAL IMPEDANCE	4Ω	4Ω
CROSSOVER FREQUENCY	2kHz	2kHz
PORT	Free Flow Flared	Free Flow Flared
INPUT CONNECTORS	2 Nos. of Speakon Sockets	Speakon + Terminal Strip
DIMENSIONS	W528 × H1188 × D496mm	W550 × H1265 × D483 mm
WEIGHT	58.90kg	67.80kg





SPX-1310
1100 WATTS

Superb high power professional 2-Way PA Loudspeaker in attractive painted enclosure made of 18 mm Plywood. Packed with two high power 38.1 cm (15") LF loudspeakers and a high frequency titanium compression horn driver give very well defined, prominent lows and brilliant highs. Acoustically treated bass reflex trapezoidal cabinet with a strong steel grille ensures protection and durability. Heavy duty metal handles allow ease of mobility and transportation. Ideal for use with high powered amplifiers for a variety of indoor and outdoor applications like Auditoria, DJs, Live Performances etc.



SPX-1610
1400 WATTS

Ultra high power professional 2-Way PA Loudspeaker in attractive painted enclosure made of 18 mm Plywood. Fitted with two high power 38.1 cm (15") LF loudspeakers and a powerful titanium compression horn driver give very well defined, prominent lows and brilliant highs. Acoustically treated bass reflex trapezoidal cabinet with a strong steel grille ensures protection and durability. Special trapezoidal profile of the cabinet for better stackability. Heavy duty metal handles allow ease of mobility and transportation. Ideal for use with high powered amplifiers for a variety of indoor and outdoor applications like Auditoria, DJs, Live Performances etc.

SPECIFICATIONS	SPX-1310	SPX-1610
POWER RATING	1100W RMS/2200W Programme	1400W RMS/2800W Programme
CONFIGURATION	Two Way	Two Way
FREQUENCY RESPONSE	35-20,000Hz	45-20,000Hz
LOW FREQUENCY SPEAKER	2 × 381 mm (15"), , Ø101.6 mm (4") Voice coil	2 × 381 mm (15") LF Speaker
HIGH FREQUENCY UNIT	Dynamic Horn 177.8 mm (7") × 406.4 mm (16")	Dynamic Horn 230 mm (9") × 354 mm (13.9")
SPL at (1W/1m)	103dB	103dB
MAX. RATED SPL	133dB	134dB
NOMINAL IMPEDANCE	4Ω	4Ω
CROSSOVER FREQUENCY	2kHz	2kHz
PORT	Free Flow Flared	Free Flow Flared
INPUT CONNECTORS	2 Nos. of Speakon Sockets	2 Nos. of Speakon Sockets
DIMENSIONS	W542 × H1253 × D475 mm	W485 × H1260 × D510 mm
WEIGHT	63.45kg	62.30kg

SPX-2010

1800 WATTS



Super power professional 2-Way PA Loudspeaker in attractive painted enclosure made of 18 mm Plywood. Fitted with two high power 38.1 cm (15") LF loudspeakers and a powerful titanium compression horn driver to deliver prominent lows, bright mids and brilliant highs. Acoustically treated bass reflex cabinet with a strong steel grille ensures protection and durability. Special trapezoidal profile of the cabinet for better stackability. Heavy duty metal handles allow ease of mobility and transportation. Ideal for use with high powered amplifiers for a variety of indoor and outdoor applications like Auditoria, DJs, Live Performances etc.

SPECIFICATIONS	SPX-2010
POWER RATING	1800W RMS/3600W Programme
CONFIGURATION	Two Way
FREQUENCY RESPONSE	42-20,000Hz
LOW FREQUENCY SPEAKER	2 × 381 mm (15") LF Speaker Ø101.6 mm (4") Voice coil
HIGH FREQUENCY UNIT	Dynamic Horn 230 mm (9") × 354 mm (13.9")
SPL at (1W/1m)	103dB
MAX. RATED SPL	135dB
NOMINAL IMPEDANCE	4Ω
CROSSOVER FREQUENCY	2kHz
PORT	Free Flow Flared
INPUT CONNECTORS	2 Nos. of Speakon Sockets
DIMENSIONS	W485 × H1260 × D510 mm
WEIGHT	63.40kg





SRM-120

100 WATTS

Compact 2-Way Stage Monitor Loudspeaker comprising of a single 30.48 cm (12") Full Range Dual Cone Speaker and a Piezo Horn Tweeter. An optimally angled enclosure for effective floor monitoring in various indoor & outdoor applications. The system is housed in an acoustically treated Bass Reflex enclosure made of 18 mm board and carpet covered.



SRM-220

200 WATTS

Compact 2-Way Stage Monitor Loudspeaker comprising of a single 38.1 cm (15") Full Range Dual Cone Speaker and a Piezo Horn Tweeter. The unique multi functional trapezoidal design of the enclosure for effective floor monitoring in various indoor & outdoor applications. The system is housed in an acoustically treated Bass Reflex enclosure made of 18 mm board and carpet covered. An On/Off switch for the piezo speaker is provided to limit extended HF, if desired. Stand mount adaptor is provided at the bottom.

SPECIFICATIONS	SRM-120	SRM-220
POWER RATING	100W RMS/200W Programme	200W RMS/400W Programme
CONFIGURATION	Two Way	Two Way
FREQUENCY RESPONSE	55-20,000Hz	50-20,000Hz
LOW FREQUENCY SPEAKER	1 × 304.8 mm (12"), Ø38.1 mm (1.5") Voice Coil	1 × 381 mm (15"), Ø50.8 mm (2.0") Voice Coil
HIGH FREQUENCY UNIT	1 × Piezo Horn Tweeter 50.8 mm (2") × 127 mm (5")	1 × Piezo Horn Tweeter 76.2 mm (3") × 152.4 mm (6")
SPL at (1W/1m)	97dB	98dB
MAX. RATED SPL	117dB	121dB
NOMINAL IMPEDANCE	8Ω	8Ω
PORT	Free Flow Flared	Free Flow Flared
INPUT CONNECTORS	1/4" Phone Jack + Terminal Strip	1/4" Phone Jack + Terminal Strip
DIMENSIONS	W425 × H560 × D358 mm	W520 × H690 × D420 mm
WEIGHT	16.20kg	25.00kg

SMS-450 400 WATTS



Elegant & compact 2-Way Stage Monitor Loudspeaker comprising of a single 38.1 cm (15") LF Speaker and 2.54 cm (1") throat HF Compression Horn Driver. An optimally angled enclosure for effective floor monitoring in various indoor & outdoor applications. The system is housed in an acoustically treated Bass Reflex enclosure made of 18 mm board in durable paint finish. Adaptor is provided at the bottom for stand mount applications. Heavy duty metal handles allow ease of mobility and transportation.

SPECIFICATIONS	SMS-450
POWER RATING	400W RMS/800W Programme
CONFIGURATION	Two Way
FREQUENCY RESPONSE	45-18,000Hz
LOW FREQUENCY SPEAKER	1 × 381 mm (15"), Ø76.2 mm (3") Voice Coil
HIGH FREQUENCY UNIT	1 × Dynamic Horn 177.8 mm (7") × 406.4 mm (16")
SPL at (1W/1m)	98dB
MAX. RATED SPL	124dB
NOMINAL IMPEDANCE	8Ω
PORT	Free Flow Flared
INPUT CONNECTORS	2 Nos. of Speakon Socket
DIMENSIONS	W700 × H400 × D525mm
WEIGHT	29.80 kg



PA Active Loudspeaker - Stage Monitor

SMS-450P
400 WATTS



Rear Panel



Professional 2-Way Active Stage Monitor Loudspeaker has built-in Bi-Amplifier for LF and HF driver separately. An optimally angled enclosure for effective floor monitoring in various indoor & outdoor applications. The system is housed in an acoustically treated Bass Reflex enclosure made of 18 mm board in durable paint finish. Adaptor is provided at the bottom for stand mount applications. Heavy duty metal handles allow ease of mobility and transportation.

- 1 x Balanced Mic/Line Input selectable through a push switch.
- 1 x Line Input can be used for connecting balanced MONO signal through jack or unbalanced STEREO signal source through dual RCA.
- Balanced output to link another SMS-450P or for recording on a computer, record player.
- Switchable balanced output either as a Loop through output of Input-1 or a mix output of Input-1 and 2.
- 2-Way Speaker System: 38.1cm (15") LF Woofer, Ø76.2cm (3.0") Voice Coil and Dynamic Horn 177.8 mm (7") × 406.4 mm (16").

SPECIFICATIONS	SMS-450P
POWER OUTPUT (Bi-AMP)	LF: 350W RMS at 1% THD Class H, HF: 50W RMS at 1% THD Class AB
OUTPUT REGULATION	Better than 0.5dB
INPUT CHANNELS	INPUT-1: MIC 20mV/3kΩ balanced, LINE: 775mV/10kΩ balanced, INPUT-2: LINE (Jack) 250mV/20kΩ balanced, RCA: 250mV (L&R)/10kΩ
FREQUENCY RESPONSE	50-20,000Hz ±3DB
CROSSOVER FREQUENCY	2.5kHz, Filter Slope 24dB per octave
SIGNAL TO NOISE RATIO	60dB
TONE CONTROLS	Bass: ±5dB at 100Hz, Treble: ±5dB at 10kHz
OUTPUT	(a) Loop through (INPUT-1): 20mV or 775mV, (b) Mixed Output (1+2): 775mV/1kΩ
PROTECTIONS	AC: Fuse 1 × 5A (T 5A L) DC: Fuse 2 × 8A (T 8A L)
POWER SUPPLY	AC: 220-240V 50/60Hz
AC POWER CONSUMPTION	500VA
DIMENSIONS	W700 × H400 × D525mm
WEIGHT	35.50kg



VX-200 200 WATTS



Compact & portable 200W, 2-Way PA Loudspeaker comprises of a high performance 25.4 cm (10") 200W LF speaker and a reliable HF driver. Ideal for use in a wide variety of speech & music applications.

- Rugged & portable bass reflex cabinet moulded with a special polypropylene plastic material. Equipped with a professional passive crossover network using low resistance inductors & high quality metallised polyester capacitors.
- Special cabinet profile allows functional flexibility in various professional audio applications such as stage monitors, live sound reinforcement and installed sound systems. A pole socket is provided at the bottom for easy stand mounting as well as wall mounting.
- Three integrated M8 flying points on top side and right side of the cabinet enable vertical and horizontal suspension applications.

VX-300 300 WATTS



Compact & exquisite 300W, 2-Way PA Loudspeaker comprises of a high performance 30.4 cm (12") 300W LF speaker and a reliable HF driver. Ideal for use in a wide variety of speech & music applications.

- Rugged & portable bass reflex cabinet moulded with a special polypropylene plastic material. Equipped with a professional passive crossover network using low resistance inductors & high quality metallised polyester capacitors.
- Special cabinet profile allows functional flexibility in various professional audio applications such as stage monitors, live sound reinforcement and installed sound systems. A pole socket is provided at the bottom for easy stand mounting as well as wall mounting.
- Three integrated M8 flying points on top side and right side of the cabinet enable vertical and horizontal suspension applications.

VX-400 400 WATTS



High quality 400W, 2-Way PA speaker Loudspeaker comprises of a high performance 38.1 cm (15") 400W LF speaker and a reliable HF driver. Ideal for use in a wide variety of speech & music applications.

- Rugged & portable bass reflex cabinet moulded with a special polypropylene plastic material. Equipped with a professional passive crossover network using low resistance inductors & high quality metallised polyester capacitors.
- Special cabinet profile allows functional flexibility in various professional audio applications such as stage monitors, live sound reinforcement and installed sound systems. A pole socket is provided at the bottom for easy stand mounting as well as wall mounting.
- Three integrated M8 flying points on top side and right side of the cabinet enable vertical and horizontal suspension applications.

SPECIFICATIONS	VX-200	VX-300	VX-400
POWER RATING	200W RMS/400W Programme	300W RMS/600W Programme	400W RMS/800W Programme
CONFIGURATION	Two Way	Two Way	Two Way
FREQUENCY RESPONSE	65-18,000Hz	60-18,000Hz	45-18,000Hz
LOW FREQUENCY SPEAKER	1 × 254 mm (10"), Ø50.8 mm (2.0") CCAW Voice Coil	1 × 304.8 mm (12"), Ø63.5 mm (2.5") CCAW Voice Coil	1 × 381 mm (15"), Ø76.2 mm (3.0") CCAW Voice Coil
HIGH FREQUENCY UNIT	Dynamic Horn, Ø25.4 mm (1") Voice Coil	Dynamic Horn, Ø44.45 mm (1.75") Voice Coil	Dynamic Horn, Ø44.45 mm (1.75") Voice Coil
SPL at (1W/1m)	94dB	97dB	98dB
MAX. RATED SPL	117dB	122dB	124dB
NOMINAL IMPEDANCE	8Ω	8Ω	8Ω
PORT	Free Flow Flared	Free Flow Flared	Free Flow Flared
INPUT CONNECTORS	1/4" Phone Jack + Push Terminals	Speakon + Push Terminals	2 Nos. of Speakon Sockets
DIMENSIONS	W325 × H485 × D255 mm	W385 × H585 × D305 mm	W460 × H690 × D370 mm
WEIGHT	9.70kg	16.00kg	22.10kg



PA Active Loudspeaker - Subwoofer

SUB-300A 300 WATTS



Rear View



Compact and elegant 300W powered subwoofer loudspeaker for use in a variety of indoor and open air applications. It comprises of an efficient 30.48 cm (12") subwoofer and a matching built-in amplifier for delivering powerful deeper bass response. The system is housed in a rugged bass reflex enclosure with excellent texture paint finish. The rear plate has various features like BYPASS switch for high pass filter, PHASE reversal switch and GROUND lift switch which are easily selectable through push switches. It also provides ease of interconnections through a variety of XLR and COMBO connectors. A stand adaptor has been provided at the top of the cabinet for pole mounting a full range speaker system. Strong grille is designed to provide necessary protection to the speaker as well as professional appearance to the product. Built-in handles for smooth handling and easy portability of the product.

SPECIFICATIONS	SUB-300A
POWER OUTPUT	300W RMS
INPUT	1V / 0dBu
FREQUENCY RESPONSE (-6dB)	47-125 Hz
SPL at (1W/1m)	96dB
MAX. RATED SPL	121dB
LOW FREQUENCY SPEAKER	1 × 304.8 mm (12") with Ø63.5 mm (2.5") Voice Coil
INPUT CONNECTORS	LEFT/MONO: COMBO (XLR+ 1/4" Stereo Jack), RIGHT: F/XLR, LINK L&R: 2 × M/XLR
OUTPUT CONNECTORS	LEFT/MONO & RIGHT: 2 × M/XLR
PROTECTION	AC: Fuse 1×3A (T 3A L)
POWER SUPPLY	AC: 220-240V 50/60Hz
AC POWER CONSUMPTION	400 VA
DIMENSIONS	W530 × H370 × D480 mm
WEIGHT	18.60kg



SWX-650 650 WATTS

The SWX-650 is a professional high power SUBWOOFER employing an extremely efficient 46 cm (18") LF driver with an extended low frequency response. It is the perfect solution to any need where significant extension of the low frequency output is required. The system is housed in a Rugged Bass Reflex Enclosure made of 18 mm board. The cabinet has been reinforced with bracing and is Carpet covered which keeps the first day appearance longer. A stand adapter has been provided at the top of the cabinet for pole mounting a full range speaker. The cabinet is fitted with heavy duty handles for ease of transportation. The strong metal grille protects the speaker from unavoidable strokes.



SWX-1000 1000 WATTS

SWX-1000 is a high reliability super power SUBWOOFER with exceptional distortion-free low frequency response. It is fitted with a 46 cm (18") LF driver having 12.7 cm (5") inside/outside voice coil wound on a polyimide fibre glass former. The speaker has an aluminium demodulating ring for better heat dissipation and a specially treated cone for water splash resistance. The cabinet is rugged and specially braced to withstand intense vibrations. Wide port design for increased efficiency. A stand adapter has been provided at the top of the cabinet for pole mounting a full range speaker. The cabinet is fitted with heavy duty handles for ease of transportation. The strong metal grille protects the speaker from unavoidable strokes.

SPECIFICATIONS	SWX-650	SWX-1000
POWER RATING	650W RMS/1300W Programme	1000W RMS/2000W Programme
CONFIGURATION	One Way	One Way
FREQUENCY RESPONSE	30-250Hz	36-200Hz
LOW FREQUENCY SPEAKER	1 × 460 mm (18") with Ø101.6 mm (4") Edge Wound Voice Coil	1 × 460 mm (18") with Ø127 mm (5") Inside/Outside Wound Voice Coil
SPL at (1W/1m)	99dB	99dB
MAX. RATED SPL	127dB	129dB
NOMINAL IMPEDANCE	8Ω	8Ω
PORT	Free Flow Flared	Free Flow Flared
INPUT CONNECTORS	Terminal Strip + Speakon	Terminal Strip + Speakon
DIMENSIONS	W575 × H780 × D500 mm	W610 × H845 × D540 mm
WEIGHT	47.20kg	53.00kg





SWX-1010 1000 WATTS

SWX-1010 is a compact and powerful super power SUBWOOFER with exceptional distortion-free low frequency response. It is fitted with a 46 cm (18") LF driver having 12.7 cm (5") inside/outside voice coil wound on a polyimide fibre glass former. The speaker has an aluminium demodulating ring for better heat dissipation and a specially treated cone for water splash resistance. The cabinet is rugged and specially braced to withstand intense vibrations. The enclosure is made of 18 mm Plywood and fitted with four heavy duty handles, a recessed terminal plate and four indexed feet for ease of stacking. The strong metal grille protects the speaker from unavoidable strokes.



SWX-1510 1500 WATTS

Compact and rugged 1500W professional subwoofer driven by an efficient 46 cm (18") LF driver to provide excellent bass response and high power handling capacity. Fitted in a strong and durable thick wooden enclosure which is well braced internally and attractively paint finished externally. The enclosure design suits all types of installed and touring applications. Strong extra-thick grille is designed to give required protection to the speaker and professional appearance to the product. The enclosure is made of 18mm Plywood and fitted with four heavy duty handles for easy handling. Four indexed feet on top surface provide easy and secure stacking of multiple cabinets. Two speakon connectors on the rear terminal plate are provided for quick & convenient connections.

SPECIFICATIONS	SWX-1010	SWX-1510
POWER RATING	1000W RMS/2000W Programme	1500W RMS/3000W Programme
CONFIGURATION	One Way	One Way
FREQUENCY RESPONSE	36-200Hz	40-250Hz
LOW FREQUENCY SPEAKER	1 × 460 mm (18") with Ø127 mm (5") Inside/Outside Wound Voice Coil	1 × 460 mm (18") with Ø 127 mm (5") I/O Copper Voice Coil
SPL at (1W/1m)	99dB	98dB
MAX. RATED SPL	129dB	129dB
NOMINAL IMPEDANCE	8Ω	8Ω
PORT	Free Flow Flared	Free Flow Flared
INPUT CONNECTORS	Terminal Strip + Speakon	2 Nos. of Speakon Sockets
DIMENSIONS	W538 × H710 × D700 mm	W605 × H785 × D605 mm
WEIGHT	55.35kg	59.60kg

SWT-1310 1300 WATTS



Rugged & reliable 1300W professional subwoofer driven by an efficient 46 cm (18") LF driver to provide superb bass response with high power handling capacity. Fitted in a strong and durable thick wooden enclosure which is well braced internally and attractively paint finished externally. The enclosure design suits all types of installed and touring applications. Strong extra-thick grille is designed to give required protection to the speaker and professional appearance to the product. The enclosure is made of 18mm Plywood and fitted with heavy duty handles for easy handling. A stand adapter has been provided at the top of the cabinet for pole mounting a full range speaker. Four indexed feet on top surface provide easy and secure stacking of multiple cabinets. Two speakon connectors on the rear terminal plate are provided for quick & convenient connections.

SPECIFICATIONS	SWT-1310
POWER RATING	1300W RMS/2600W Programme
CONFIGURATION	One Way
FREQUENCY RESPONSE	36-250Hz
LOW FREQUENCY SPEAKER	1 × 460 mm (18") with Ø 114.3 mm (4.5") I/O Copper Voice Coil
SPL at (1W/1m)	97dB
MAX. RATED SPL	128dB
NOMINAL IMPEDANCE	8Ω
PORT	Free Flow Flared
INPUT CONNECTORS	2 Nos. of Speakon Sockets
DIMENSIONS	W605 × H820 × D620 mm
WEIGHT	55.25kg



Cabinet Loudspeakers - Subwoofer

SWX-2010 2000 WATTS



Strong and powerful 2000W professional subwoofer driven by an efficient 46 cm (18") LF driver to provide excellent bass response and high power handling capacity. Fitted in a strong and durable thick wooden enclosure which is well braced internally and attractively paint finished externally. The enclosure design suits all types of installed and touring applications. Strong extra-thick grille is designed to give required protection to the speaker and professional appearance to the product. The enclosure is made of 18 mm Plywood and fitted with four heavy duty handles for easy handling. Four indexed feet on top surface provide easy and secure stacking of multiple cabinets. Two speakon connectors on the rear terminal plate are provided for quick & convenient connections.

SPECIFICATIONS	SWX-2010
POWER RATING	2000W RMS/4000W Programme
CONFIGURATION	One Way
FREQUENCY RESPONSE	40-250Hz
LOW FREQUENCY SPEAKER	1 × 460 mm (18") with Ø 127 mm (5") I/O Copper Voice Coil
SPL at (1W/1m)	98dB
MAX. RATED SPL	131dB
NOMINAL IMPEDANCE	8Ω
PORT	Free Flow Flared
INPUT CONNECTORS	2 Nos. of Speakon Sockets
DIMENSIONS	W610 × H900 × D735 mm
WEIGHT	73.20kg

SWX-1300DX

1300 WATTS



Rugged cabinet loudspeaker with two extremely efficient 46cm (18") LF drivers for higher power handling capacity, deeper bass, and smoother spatial distribution of the extended bass. Very strong carpet covered cabinet with 25 mm thick wooden baffle and extensive internal bracing to prevent unwanted vibrations and rattling. Provided with an attractive & modern extra-thick grille, and four steel handles for easy handling. Bass reflex design tuned with a large, wide angle port. An ideal cabinet speaker for use with high power amplifiers for reinforcement of the extended low frequency spectrum.

SPECIFICATIONS	SWX-1300DX
POWER RATING	1300W RMS/2600W Programme
CONFIGURATION	One Way
FREQUENCY RESPONSE	30-250Hz
LOW FREQUENCY SPEAKER	2 x 460 mm (18") with Ø 101.6 mm (4") Edge Wound Voice Coil
SPL at (1W/1m)	102dB
MAX. RATED SPL	133dB
NOMINAL IMPEDANCE	4Ω
PORT	Free Flow Flared
INPUT CONNECTORS	2 Nos. of Speakon Sockets
DIMENSIONS	W1075 × H660 × D610 mm
WEIGHT	83.00kg



Cabinet Loudspeakers - Subwoofer

SWX-2100 2000 WATTS



Compact and powerful 2000W professional subwoofer driven by two efficient 46 cm (18") LF driver to provide excellent bass and super power handling capacity. Built into a strong and durable thick wooden enclosure which is well braced internally and attractively paint finished externally. This bass reflex enclosure design, with minimum footprint, suits all types of installed and touring applications. Strong extra-thick grille is designed to give required protection to the speakers and professional appearance to the product. The enclosure is made of 18 mm Plywood and fitted with four heavy duty handles for easy handling. Six indexed feet on top surface provide easy and secure stacking of subwoofer cabinets. Two speakon connectors on the rear terminal plate are provided for quick & convenient connections.

SPECIFICATIONS	SWX-2100
POWER RATING	2000W RMS/4000W Programme
CONFIGURATION	One Way
FREQUENCY RESPONSE	36-200Hz
LOW FREQUENCY SPEAKER	2 × 460 mm (18") with Ø127 mm (5") Inside/Outside Wound Voice Coil
SPL at (1W/1m)	102dB
MAX. RATED SPL	135dB
NOMINAL IMPEDANCE	4Ω
PORT	Free Flow Flared
INPUT CONNECTORS	2 Nos. of Speakon Sockets
DIMENSIONS	W1000 × H675 × D706 mm
WEIGHT	94.55kg

SWX-3100 3000 WATTS



Rugged and powerful 3000W professional subwoofer system driven by two efficient 46 cm (18") LF drivers to generate excellent bass response and provide super power handling capacity. Strong and durable thick wooden enclosure which is well braced and attractively paint finished. The enclosure design suits all types of installed and touring applications. Strong extra-thick grille is designed to give required protection to the speakers and professional appearance to the product. The enclosure is made of 18 mm Plywood and fitted with four heavy duty handles for easy handling. Six indexed feet on top surface provide easy and secure stacking of subwoofer cabinets. Two speakon connectors on the rear terminal plate are provided for quick & convenient connections.

SPECIFICATIONS	SWX-3100
POWER RATING	3000W RMS/6000W Programme
CONFIGURATION	One Way
FREQUENCY RESPONSE	40-250Hz
LOW FREQUENCY SPEAKER	2 × 460 mm (18") with Ø 127 mm (5") I/O Copper Voice Coil
SPL at (1W/1m)	101dB
MAX. RATED SPL	133dB
NOMINAL IMPEDANCE	4Ω
PORT	Free Flow Flared
INPUT CONNECTORS	2 Nos. of Speakon Sockets
DIMENSIONS	W1215 × H610 × D790 mm
WEIGHT	117.20kg



Cabinet Loudspeakers - Subwoofer

SWX-3700N 3600 WATTS



Robust and powerful 3600W professional subwoofer system driven by two efficient 46 cm (18") Neodymium LF drivers to generate extreme bass response and provide super power handling capacity. Strong and durable wooden enclosure which is well braced and attractively paint finished. The enclosure design suits all types of installed and touring applications. Strong extra-thick grille is designed to give required protection to the speakers and professional appearance to the product. The enclosure is made of 18 mm Plywood and fitted with four heavy duty handles for easy handling. Six indexed feet on top surface provide easy and secure stacking of subwoofer cabinets. Two speakon connectors on the rear terminal plate are provided for quick & convenient connections.

SPECIFICATIONS	SWX-3700N
POWER RATING	3600W RMS/7200W Programme
CONFIGURATION	One Way
FREQUENCY RESPONSE	35-250Hz
LOW FREQUENCY SPEAKER	2 × 460 mm (18") with Ø 114 mm (4.5") Aluminium I/O Voice Coil
SPL at (1W/1m)	102dB
MAX. RATED SPL	137dB
NOMINAL IMPEDANCE	4Ω
PORT	Free Flow Flared
INPUT CONNECTORS	2 Nos. of Speakon Sockets
DIMENSIONS	W1215 × H610 × D790 mm
WEIGHT	102.00kg

ALX-7500 600 WATTS



ALX-7500 is an attractive and rugged Line Array Loudspeaker. Each cabinet of ALX-7500 comprises of a single high power 30.48 cm (12") Neodymium LF driver and a high performance HF driver to deliver crisp, loud and clear sound in a variety of indoor and outdoor applications.

- Each line array cabinet is designed to provide controlled & coherent coverage pattern with excellent high frequency response.
- Comprises of a powerful HF driver with a waveguide horn for constant curvature line array system.
- Smart rigging arrangement for quick & secure installation.
- Professional 2-way passive crossover network with HF protection.
- Selection of HF long throw (0dB) and short throw (-3dB) through a slide switch, available on terminal plate.
- Strong, attractive and well braced speaker cabinet in durable paint finish.
- Heavy duty steel grille with acoustically transparent foam to protect speakers from various adverse working conditions.
- A sturdy and rugged flybar frame is available for rigging the line array cabinets.
- Suitable for a wide variety of applications in Fixed Installations, Rental, Djs and Live Sound Reinforcement.

SPECIFICATIONS	ALX-7500
POWER RATING	600W RMS
CONFIGURATION	Two Way
FREQUENCY RESPONSE	52-20,000Hz
LOW FREQUENCY SPEAKER	1 × 304.8 mm (12"), Ø89 mm (3.5") Voice Coil
HIGH FREQUENCY UNIT	Waveguide Horn with 1 × 38.1 mm (1.5") Throat Compression Driver
SPL (1W/1m)	98dB
MAX RATED SPL	126dB
NOMINAL IMPEDANCE	8Ω
HORIZONTAL COVERAGE ANGLE	120°
VERTICAL COVERAGE ANGLE	10°
VARIABLE SPLAY ANGLES	0°, 2°, 4°, 6°, 8°, 10°
CONNECTORS	2 Nos. of Speakon Sockets
DIMENSIONS	W695 × H360 × D530 mm
WEIGHT	35.00kg



Line Array Loudspeakers

ALA-9000 800 WATTS



ALA-9000 is a compact and rugged Line Array Loudspeaker. Each cabinet of ALA-9000 comprises of two high power 30.48 cm (12") LF drivers and a high performance HF driver to deliver crisp, loud and clear sound in a variety of indoor and outdoor applications.

- Each line array cabinet is designed to provide uniform coverage with excellent high frequency response.
- Comprises of a powerful HF driver with matching horn for constant curvature line array system.
- Smart rigging arrangement for quick & secure installation.
- Professional 2-way passive crossover network.
- Strong, attractive and well braced speaker cabinet in durable paint finish.
- Heavy duty steel grille with acoustically transparent foam to protect speakers from various adverse working conditions.
- A sturdy and rugged flybar frame is available for rigging the line array cabinets.
- Suitable for a wide variety of applications in Fixed Installations, Rental, Djs and Live Sound Reinforcement.

SPECIFICATIONS	ALA-9000
POWER RATING	800W RMS
CONFIGURATION	Two Way
FREQUENCY RESPONSE	48-20,000Hz
LOW FREQUENCY SPEAKER	2 × 304.8 mm (12"), Ø76.2 mm (3") Voice Coil
HIGH FREQUENCY UNIT	HF Horn with 1 × 51 mm (2") Throat Compression Driver
SPL (1W/1m)	99dB
MAX RATED SPL	128dB
NOMINAL IMPEDANCE	4Ω
HORIZONTAL COVERAGE ANGLE	90°
VERTICAL COVERAGE ANGLE	40°
VARIABLE SPLAY ANGLES	0°, 2°, 4°, 6°, 8°
CONNECTORS	2 Nos. of Speakon Sockets
DIMENSIONS	W1060 x H374 x D460 mm
WEIGHT	48.50kg

ALX-15000M 1200 WATTS



ALX-15000M is a rugged and reliable Line Array Loudspeaker. Each cabinet comprises of two high power 30.48 cm (12") Neodymium LF drivers and two high performance HF drivers to deliver crisp, loud and clear sound in a variety of indoor & outdoor applications.

- Each line array cabinet is designed to provide controlled & coherent coverage pattern with excellent high frequency response.
- Comprises of two powerful HF drivers with a waveguide horn for constant curvature line array system.
- Smart rigging arrangement for quick & secure installation.
- Professional 2-way passive crossover network with HF protection.
- Strong, attractive and well braced speaker cabinet in durable paint finish.
- Heavy duty steel grille with acoustically transparent foam to protect speakers from various adverse working conditions.
- A sturdy and rugged flybar frame is available for rigging the line array cabinets.
- Suitable for a wide variety of applications in Fixed Installations, Rental, Djs and Live Sound Reinforcement.

SPECIFICATIONS	ALX-15000M
POWER RATING	1200W RMS
CONFIGURATION	Two Way
FREQUENCY RESPONSE	58-20,000Hz
LOW FREQUENCY SPEAKER	2 × 304.8 mm (12"), Ø89 mm (3.5") Voice Coil
HIGH FREQUENCY UNIT	Waveguide Horn with 2 × 38.1 mm (1.5") Throat Compression Driver
SPL (1W/1m)	97dB
MAX RATED SPL	128dB
NOMINAL IMPEDANCE	8Ω
HORIZONTAL COVERAGE ANGLE	120°
VERTICAL COVERAGE ANGLE	10°
VARIABLE SPLAY ANGLES	0°, 2°, 4°, 6°, 8°, 10°
CONNECTORS	2 Nos. of Speakon Sockets
DIMENSIONS	W1050 x H360 x D530 mm
WEIGHT	48.70kg



PA Speakers

High quality 12" mid-bass speaker



AS12-X100® 100 WATTS

- Sturdy pressed metal frame in elegant brown colour.
- Kapton former voice coil for withstanding high temperature.
- Suitable for use in compact 2-way sealed as well as bass reflex enclosures.
- Excellent low frequency response makes it ideal for Dandiya-Ras, DJs & General PA applications.

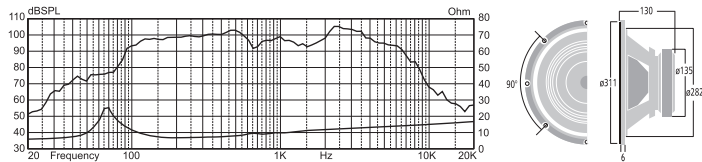

High quality 15" mid-bass speaker



AS15-X200® 200 WATTS

- Sturdy pressed metal frame in elegant brown colour.
- Special high temperature voice coil for exceptional thermal capabilities.
- Suitable for use in compact 2-way sealed as well as bass reflex enclosures.
- Excellent low frequency response makes it ideal for Dandiya-Ras, DJs & General PA applications.

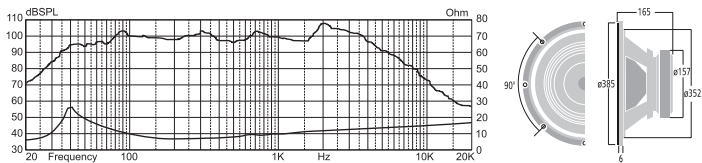

SPECIFICATIONS	AS12-X100®	AS15-X200®
POWER RATING	100W RMS/200W Programme	200W RMS/400W Programme
NOMINAL DIAMETER	305 mm (12")	380 mm (15")
NOMINAL IMPEDANCE	8Ω	8Ω
SENSITIVITY (1W/1m)	97dB	98dB
MAGNET WEIGHT	1.1kg	1.54kg
RESONANT FREQUENCY (Fs)	70Hz	45Hz
DC RESISTANCE (Re)	6.0Ω	6.0Ω
ELECTROMAGNETIC Q (Qes)	0.79	0.58
MECHANICAL Q (Qms)	5.5	9.6
TOTAL Q (Qts)	0.69	0.54
COMPLIANCE EQUIVALENT VOLUME (VAS)	74.23 Litr	115 Litr
SURFACE AREA OF CONE (Sd)	510cm ²	830cm ²
REFERENCE EFFICIENCY (η ₁₀)	3.09%	2.1%
VOICE COIL	1.5"	2.0"
OVERHANG (X _{max})	2.0mm	3.5 mm
MOVING MASS (M _{ms})	25.5gm	73gm
BL PRODUCT (BL)	9.2TM	13.4TM
OVERALL DIAMETER	311 mm	385 mm
DEPTH	130 mm	165 mm
BAFFLE HOLE DIAMETER	285 mm	355 mm
BOLT MOUNT DIAMETER (PCD)	292 mm (8 Bolts)	373 mm (8 Bolts)
WEIGHT	3.20kg	4.90kg

High efficiency 12" dual cone full range speaker

SK-12FR[®]X/SK-12FR[®]Z

100 WATTS



- They are 30.48cm (12") dual cone full range PA speakers with a very wide frequency range 50-16,000Hz.
- Impedance of SK-12FRX is 8Ω and SK-12FRZ is 16Ω.
- High quality specially designed imported parts for low distortion and a clean transparent sound.

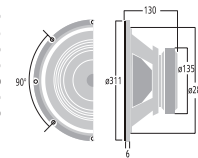
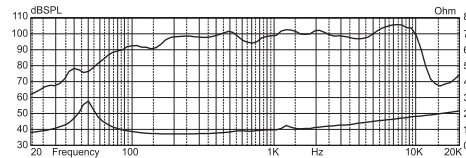

High efficiency 12" dual cone full range speaker

DX12-F200[®]/DZ12-F200[®]

200 WATTS



- 30.48cm (12") dual cone speaker with wide spectrum frequency response.
- High quality specially designed imported cones and spider for extremely clear, low distortion sound reproduction.
- Impedance of DX12-F200 is 8Ω and DZ12-F200 is 16Ω.
- 5.08 cm (2") CCAW voice coil with high temperature rating for safe, reliable operation.

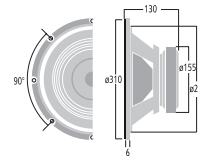
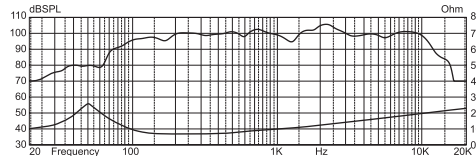

High efficiency 15" dual cone full range speaker

SK-15FR[®]X/SK-15FR[®]Z

200 WATTS



- It is a 38.1 cm (15") high quality dual cone full range PA speaker with a very wide frequency range 50-16,000Hz.
- Impedance of SK-15FRX is 8Ω and SK-15FRZ is 16Ω.
- High quality specially designed imported parts for low distortion & clean sound.

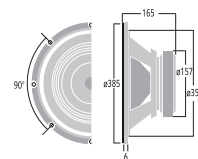
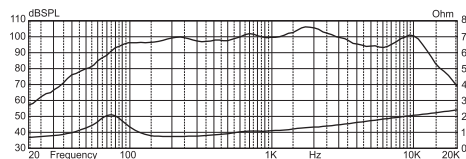

SPECIFICATIONS	SK-12FR [®] X/SK-12FR [®] Z	DX12-F200 [®] /DZ12-F200 [®]	SK-15FR [®] X/SK-15FR [®] Z
POWER RATING	100W RMS/200W Programme	200W RMS/400W Programme	200W RMS/400W Programme
NOMINAL DIAMETER	305 mm (12")	305 mm (12")	380 mm (15")
NOMINAL IMPEDANCE	8 Ω /16 Ω	8 Ω /16 Ω	8 Ω /16 Ω
SENSITIVITY (1W/1m)	97dB	97dB	98 dB
MAGNET WEIGHT	1.1kg	1.16kg	1.54kg
RESONANT FREQUENCY (Fs)	50Hz	50Hz	75Hz
DC RESISTANCE (Re)	6.4 Ω /13.0 Ω	6.8 Ω /13.0 Ω	6.5 Ω /11.0 Ω
ELECTROMAGNETIC Q (Qes)	0.758	0.92	0.91
MECHANICAL Q (Qms)	9.36	3.26	5.07
TOTAL Q (Qts)	0.7	0.72	0.77
COMPLIANCE EQUIVALENT VOLUME (VAS)	104 Litr	—	75.11Litr
SURFACE AREA OF CONE (Sd)	510cm ²	510cm ²	830cm ²
REFERENCE EFFICIENCY (ηo)	1.7%	3.6%	3.18%
VOICE COIL DIAMETER	1.5"	2.0"	2.0"
OVERHANG (Xmax)	1.5 mm	2.5 mm	4.0 mm
MOVING MASS (Mms)	35.23gm	36.7gm	60.62gm
BL PRODUCT (BL)	9.7TM	11.2TM	14.23TM
COIL INDUCTANCE (Le)	0.79mH	0.69mH	0.78mH
OVERALL DIAMETER	311 mm	313 mm	385 mm
DEPTH	130 mm	127 mm	165 mm
BAFFLE HOLE DIAMETER	285 mm	285 mm	355 mm
BOLT MOUNT DIAMETER (PCD)	292 mm (8 Bolts)	295 mm (8 Bolts)	373 mm (8 Bolts)
WEIGHT	3.20kg	4.16kg	4.90kg



PA Speakers

Medium power 12" low frequency speaker



L12-MB200® 200 WATTS

- Specially designed for use in medium power compact 2-Way speaker systems. Suitable for bass-midrange and monitoring applications.
- Robust steel frame and plasticized cloth edge composite cone.
- KAPTON former 5.08 cm (2.0") copper voice coil for withstanding high temperatures.

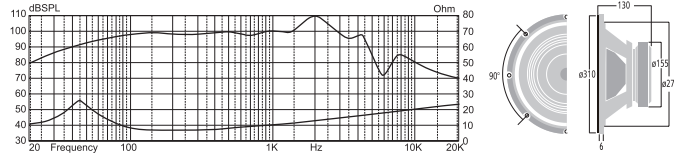

High power 12" low frequency speaker



L12-MB300 300 WATTS

- Exclusively designed for use in high power compact 2-Way speaker systems. Ideal for bass & midrange application in bass reflex cabinets.
- Strong die-cast aluminium frame for reliable performance.
- 7.62 cm (3") Copper Clad Aluminium Wire voice coil wound on GLASS FIBRE former. Gold plated push type heavy duty terminals for firm connection.

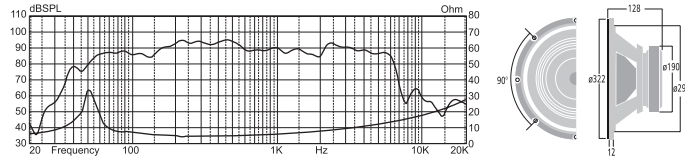

High power 12" low frequency speaker



L12-MB400 400 WATTS

- Suitable for use in high power compact 2-Way speaker systems. Ideal for bass & midrange application in bass reflex cabinets.
- Strong die-cast aluminium frame for reliable performance.
- 7.62 cm (3") Copper Clad Aluminium Wire voice coil wound on GLASS FIBRE former. Gold plated push type heavy duty terminals for firm connection.

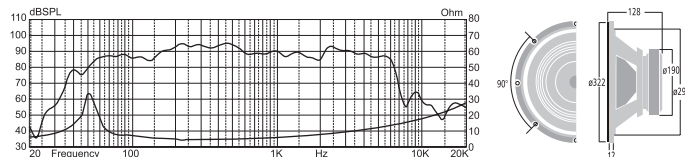

SPECIFICATIONS	L12-MB200®	L12-MB300	L12-MB400
POWER RATING	200W RMS/400W Programme	300W RMS/600W Programme	400W RMS/800W Programme
NOMINAL DIAMETER	305 mm (12")	305 mm (12")	305 mm (12")
NOMINAL IMPEDANCE	8Ω	8Ω	8Ω
SENSITIVITY (1W/1m)	97dB	99dB	99dB
MAGNET WEIGHT	1.16 Kg	2.31kg	2.31kg
RESONANT FREQUENCY (Fs)	45Hz	48Hz	48Hz
DC RESISTANCE (Re)	7Ω	5.4Ω	5.4Ω
ELECTROMAGNETIC Q (Qes)	0.46	0.33	0.33
MECHANICAL Q (Qms)	4.67	4.94	4.94
TOTAL Q (Qts)	0.42	0.30	0.30
COMPLIANCE EQUIVALENT VOLUME (VAS)	135Litr	71Litr	71Litr
SURFACE AREA OF CONE (Sd)	510cm ²	531cm ²	531cm ²
REFERENCE EFFICIENCY (η ₁₀)	1.35%	2.83%	2.83%
VOICE COIL	2.0"	3.0"	3.0"
OVERHANG (X _{max})	2.5mm	3.5 mm	3.5 mm
MOVING MASS (M _{ms})	51.9gm	54.55gm	54.55gm
BL PRODUCT (BL)	13.42TM	17.11TM	17.11TM
COIL INDUCTANCE (Le)	0.89mH	0.85mH	0.85mH
OVERALL DIAMETER	313 mm	322 mm	322 mm
DEPTH	127 mm	128 mm	128 mm
BAFFLE HOLE DIAMETER	285 mm	290 mm	290 mm
BOLT MOUNT DIAMETER (PCD)	295 mm (8 Bolts)	305 mm (8 Bolts)	305 mm (8 Bolts)
WEIGHT	4.16kg	7.30kg	7.30kg

High power 15" low frequency speaker



L15-MB300®
300 WATTS

- Excellent low and mid frequency response, Ideal for bass and bass-midrange applications in bass reflex cabinets.
- Aluminium die-cast frame with vented-gap cooling technique.
- 7.62 cm (3") CCAW voice coil wound on GLASS FIBRE former.
- Gold plated push type heavy duty terminals for firm connection.

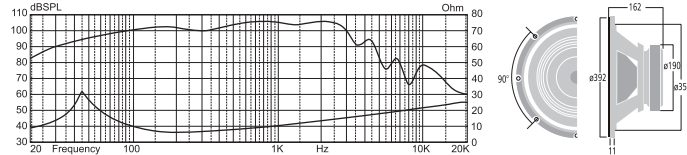

High power 15" low frequency speaker



L15-MB400®
400 WATTS

- Excellent low and mid frequency response.
- Ideal for high power 2-Way Speaker Systems.
- Triple roll, exponential cone geometry.
- High temperature copper clad aluminium wire voice coil wound on polyamide former.

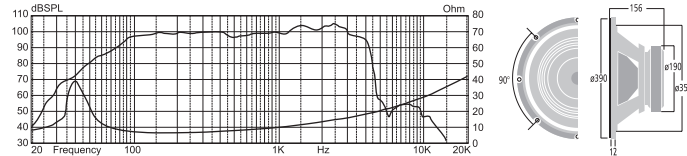

High power 15" low frequency speaker



L15-MB550
550 WATTS

- Extended low frequency, ideal for Cinema Halls and for use in professional high power full range speaker systems.
- Aluminium die-cast frame with gold plated push type heavy duty terminals.
- GLASS FIBRE former for withstanding high temperature.
- 10.16 cm (4") Edge-wound aluminium wire voice coil for higher SPL.

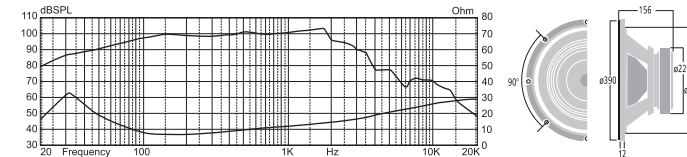

SPECIFICATIONS	L15-MB300®	L15-MB400®	L15-MB550
POWER RATING	300W RMS/600W Programme	400W RMS/800W Programme	550W RMS/1100W Programme
NOMINAL DIAMETER	380 mm (15")	380 mm (15")	380 mm (15")
NOMINAL IMPEDANCE	8Ω	8Ω	8Ω
SENSITIVITY (1W/1m)	99dB	99dB	97dB
MAGNET WEIGHT	2.31kg	2.31kg	2.85kg
RESONANT FREQUENCY (Fs)	45Hz	40Hz	33Hz
DC RESISTANCE (Re)	5.7Ω	5.8Ω	5Ω
ELECTROMAGNETIC Q (Qes)	0.32	0.41	0.34
MECHANICAL Q (Qms)	5.82	8.0	4.32
TOTAL Q (Qts)	0.3	0.39	0.32
COMPLIANCE EQUIVALENT VOLUME (VAS)	139.65Litr	168Litr	221Litr
SURFACE AREA OF CONE (Sd)	830cm ²	855cm ²	830cm ²
REFERENCE EFFICIENCY (ηo)	4.35%	2.72%	2.28%
VOICE COIL	3.0"	3.0"	4.0"
OVERHANG (Xmax)	2.5mm	6.0mm	8.0 mm
MOVING MASS (Mms)	80.31gm	91gm	107.17gm
BL PRODUCT (BL)	20.49TM	18TM	18TM
COIL INDUCTANCE (Le)	0.68mH	1.1mH	1.09mH
OVERALL DIAMETER	395 mm	389.5 mm	387 mm
DEPTH	160 mm	157 mm	158 mm
BAFFLE HOLE DIAMETER	358 mm	350 mm	354 mm
BOLT MOUNT DIAMETER (PCD)	373 mm (8 Bolts)	369 mm (8 Bolts)	369 mm (8 Bolts)
WEIGHT	8.15kg	7.80kg	9.00kg



PA Speakers

High power 15" low frequency speaker



L15-MB700 700 WATTS

- Excellent bass and mid-bass response, high power handling capacity.
- Aluminium die-cast frame with gold plated push type heavy duty terminals.
- GLASS FIBRE former for withstanding high temperature.
- 10.16 cm (4") Edge-wound aluminium wire voice coil for higher SPL.

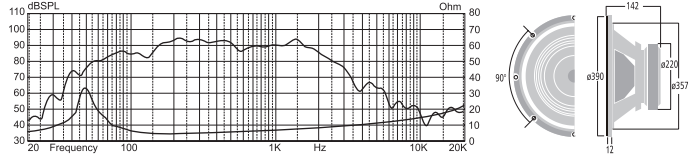

Super power 15" low frequency speaker



L15-MB900 900 WATTS

- Superb bass response, super power handling capacity.
- Aluminium die-cast frame with gold plated push type heavy duty terminals.
- GLASS FIBRE former Voice Coil for withstanding high temperature.
- 10.16 cm (4") CCAW voice coil for higher SPL and low distortion.

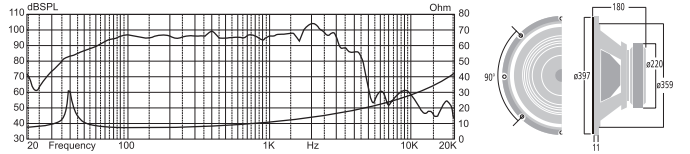

High power 18" extended low frequency speaker



L18-SW650® 650 WATTS

- Extremely great linear excursion, ideal for powerful bass and subwoofer applications. Robust aluminium die-cast frame.
- Tear resistant tetron-cotton blend rolled cloth edge.
- GLASS FIBRE former voice coil for withstanding high temperature.
- 10.16 cm (4") Edge-wound aluminium wire voice coil for higher SPL.

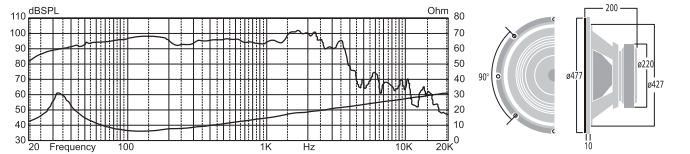

SPECIFICATIONS	L15-MB700	L15-MB900	L18-SW650®
POWER RATING	700W RMS/1400W Programme	900W RMS/1800W Programme	650W RMS/1300W Programme
NOMINAL DIAMETER	380 mm (15")	380 mm (15")	460 mm (18")
NOMINAL IMPEDANCE	8Ω	8Ω	8Ω
SENSITIVITY (1W/1m)	97dB	97dB	98dB
MAGNET WEIGHT	2.85kg	3.56kg	3.56kg
RESONANT FREQUENCY (Fs)	50Hz	42Hz	32Hz
DC RESISTANCE (Re)	5.1Ω	5.2Ω	5.1Ω
ELECTROMAGNETIC Q (Qes)	0.32	0.37	0.26
MECHANICAL Q (Qms)	5.91	12.8	5.29
TOTAL Q (Qts)	0.30	0.36	0.245
COMPLIANCE EQUIVALENT VOLUME (VAS)	109Litr	152 Litr	246 Litr
SURFACE AREA OF CONE (Sd)	830cm ²	897cm ²	1225cm ²
REFERENCE EFFICIENCY (η10)	3.5%	3.36%	3.12%
VOICE COIL	4.0"	4.0"	4.0"
OVERHANG (Xmax)	3.6 mm	9.0 mm	5.0 mm
MOVING MASS (Mms)	97.60gm	135gm	218gm
BL PRODUCT (BL)	22.92TM	21.8TM	29.64TM
COIL INDUCTANCE (Le)	1.60mH	1.23mH	1.9mH
OVERALL DIAMETER	390 mm	397mm	476 mm
DEPTH	142 mm	180 mm	205 mm
BAFFLE HOLE DIAMETER	357 mm	359 mm	424 mm
BOLT MOUNT DIAMETER (PCD)	372 mm (8 Bolts)	379 mm (8 Bolts)	450 mm (8 Bolts)
WEIGHT	11.00kg	11.60kg	13.30kg

Super power 18" extended low frequency speaker



L18-SW1000®
1000 WATTS

- Super power and reliable speaker for powerful bass & subwoofer applications.
- Robust aluminium die-cast frame with efficient heat dissipating vents. Aluminium demodulating ring for enhanced heat dissipation.
- DOUBLE SPIDER design for better excursion control. GLASS FIBRE former voice coil for withstanding high temperatures.
- 12.7 cm (5") INSIDE/OUTSIDE CCAW voice coil for higher SPL.
- Cone specially treated for water splash resistance.

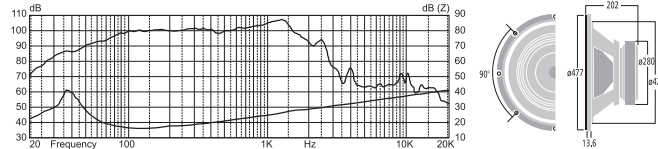

Super power 18" extended low frequency speaker



THUNDER 1845
1300 WATTS

- Powerful & efficient speaker with Extended Low Frequency Response.
- For use in Professional High Power sub-woofer Speaker Systems.
- 11.43cm (4.5") I/O copper voice coil for higher efficiency.
- Vented Aluminium Die-cast frame with built-in heat sink for enhanced heat dissipation.
- Higher grade and heavy duty ferrite magnet in rigid assembly.
- Composite treated cone paper for better strength and reliability.
- Heavy duty push type terminals for easy and firm connection.

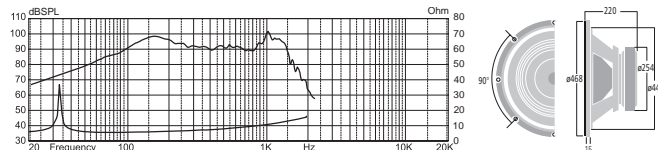

SPECIFICATIONS	L18-SW1000®	THUNDER 1845
POWER RATING	1000W RMS/2000W Programme	1300W RMS/2600W Programme
NOMINAL DIAMETER	460 mm (18")	460 mm (18")
NOMINAL IMPEDANCE	8Ω	8Ω
SENSITIVITY (1W/1m)	99dB	97dB
MAGNET WEIGHT	5.65kg	4.85kg
RESONANT FREQUENCY (Fs)	36Hz	36Hz
DC RESISTANCE (Re)	5.6Ω	4.8Ω
ELECTROMAGNETIC Q (Qes)	0.32	0.360
MECHANICAL Q (Qms)	14.70	25.4
TOTAL Q (Qts)	0.31	0.355
COMPLIANCE EQUIVALENT VOLUME (VAS)	249 Litr	142.8 Litr
SURFACE AREA OF CONE (Sd)	1257cm ²	1219cm ²
REFERENCE EFFICIENCY (η ₀)	3.6%	1.8%
VOICE COIL	5.0"	4.5"
OVERHANG (X _{max})	8.0 mm	9.4mm
MOVING MASS (M _{ms})	169gm	283.2gm
BL PRODUCT (BL)	26.0TM	29.5TM
COIL INDUCTANCE (Le)	1.91mH	1.07mH
OVERALL DIAMETER	477 mm	468 mm
DEPTH	202 mm	220 mm
BAFFLE HOLE DIAMETER	427 mm	440 mm
BOLT MOUNT DIAMETER (PCD)	451.5 mm (8 Bolts)	448 mm (8 Bolts)
WEIGHT	19.60kg	17.43kg



Super power 18"
extended low frequency speaker



L18-SW1500 1500 WATTS

- Super power & efficient speaker with Extended Low Frequency Response.
- For use in Professional High Power sub-woofer Speaker Systems.
- 12.7cm (5") I/O copper voice coil for higher efficiency.
- Vented Aluminium Die-cast frame with built-in heat sink for enhanced heat dissipation.
- Higher grade and heavy duty ferrite magnet in rigid assembly.
- Double spider design for better excursion control.
- Composite treated cone paper for better strength and reliability.
- Heavy duty push type terminals for easy and firm connection.

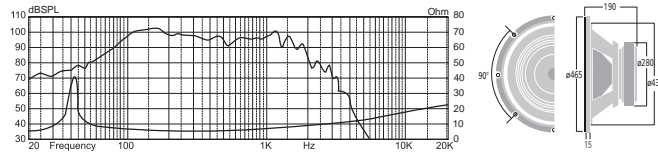

Super power 18"
extended low frequency speaker



L18-SW2000 2000 WATTS

- Strong & Powerful Speaker with Extended Low Frequency Response.
- For use in Professional High Power sub-woofer Speaker Systems.
- 12.7cm (5") I/O copper voice coil for higher efficiency.
- Vented Aluminium Die-cast frame with built-in heat sink for enhanced heat dissipation.
- Higher grade and heavy duty dual ferrite magnet in rigid assembly.
- Double spider design for better excursion control.
- Composite treated cone paper for better strength and reliability.
- Heavy duty push type terminals for easy and firm connection.

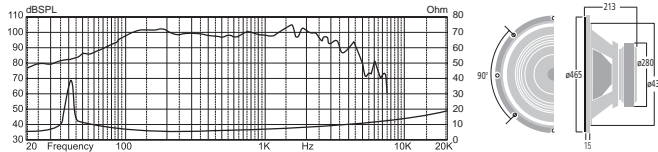

SPECIFICATIONS	L18-SW1500	L18-SW2000
POWER RATING	1500W RMS/3000W Programme	2000W RMS/4000W Programme
NOMINAL DIAMETER	460 mm (18")	460 mm (18")
NOMINAL IMPEDANCE	8Ω	8Ω
SENSITIVITY (1W/1m)	98dB	98dB
MAGNET WEIGHT	5.65kg	9.04kg
RESONANT FREQUENCY (Fs)	40Hz	40Hz
DC RESISTANCE (Re)	5.6Ω	5.6Ω
ELECTROMAGNETIC Q (Qes)	0.362	0.215
MECHANICAL Q (Qms)	9.61	10.63
TOTAL Q (Qts)	0.293	0.211
COMPLIANCE EQUIVALENT VOLUME (VAS)	158 Litr	144.4 Litr
SURFACE AREA OF CONE (Sd)	1288cm ²	1288cm ²
REFERENCE EFFICIENCY (η ₁₀)	3.1%	4.05%
VOICE COIL	5.0"	5.0"
OVERHANG (X _{max})	9.6mm	10.9 mm
MOVING MASS (M _{ms})	236gm	256.32gm
BL PRODUCT (BL)	33.0TM	40.79TM
COIL INDUCTANCE (Le)	3.92mH	2.65mH
OVERALL DIAMETER	465 mm	465 mm
DEPTH	190 mm	213 mm
BAFFLE HOLE DIAMETER	430 mm	430 mm
BOLT MOUNT DIAMETER (PCD)	442 mm (8 Bolts)	442 mm (8 Bolts)
WEIGHT	20.00kg	24.50kg

Super power 18" extended low frequency speaker



L18-SW2500
2500 WATTS

- Powerful & Rugged Speaker with Extended Low Frequency Response.
- For use in Professional High Power sub-woofer Speaker Systems.
- 12.7cm (5") I/O copper voice coil for higher efficiency.
- Vented Aluminium Die-cast frame with built-in heat sink for enhanced heat dissipation.
- Higher grade and heavy duty dual ferrite magnet in rigid assembly.
- Double spider design for better excursion control.
- Composite treated cone paper for better strength and reliability.
- Heavy duty push type terminals for easy and firm connection.

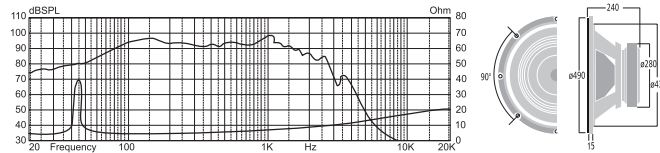

Super power 21" extended low frequency speaker



L21-SW3500
3500 WATTS

- Highly Powerful & Efficient Speaker with Extended Low Frequency Response.
- For use in Professional Very High Power Sub-Woofer Speaker Systems.
- 15.24cm (6") I/O copper voice coil for efficient and reliable performance.
- Vented Aluminium Die-cast frame and robust construction.
- Heavy duty dual ferrite magnet with rigid magnet assembly.
- Composite treated cone paper with plasticized cloth cone edge for extra strength and reliability.
- Glass Fibre former voice coil for withstanding high temperature.
- Chrome plated push type heavy duty terminals for reliable connection.

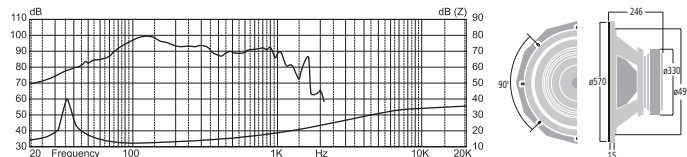

SPECIFICATIONS	L18-SW2500	L21-SW3500
POWER RATING	2500W RMS/5000W Programme	3500W RMS/7000W Programme
NOMINAL DIAMETER	460 mm (18")	533 mm (21")
NOMINAL IMPEDANCE	8Ω	8Ω
SENSITIVITY (1W/1m)	97dB	98dB
MAGNET WEIGHT	9.04kg	
RESONANT FREQUENCY (Fs)	45Hz	35Hz
DC RESISTANCE (Re)	5.6Ω	5.6Ω
ELECTROMAGNETIC Q (Qes)	0.26	0.183
MECHANICAL Q (Qms)	8.90	6.52
TOTAL Q (Qts)	0.25	0.178
COMPLIANCE EQUIVALENT VOLUME (VAS)	86.10 Litr	169 Litr
SURFACE AREA OF CONE (Sd)	1225cm ²	1735cm ²
REFERENCE EFFICIENCY (η ₀)	2.98%	4.11%
VOICE COIL	5.0"	6.0"
OVERHANG (X _{max})	10.9mm	8.35 mm
MOVING MASS (M _{ms})	298.7gm	487.23gm
BL PRODUCT (BL)	42.88TM	57.96TM
COIL INDUCTANCE (Le)	2.74mH	5.50mH
OVERALL DIAMETER	466 mm	573 × 555 mm
DEPTH	240 mm	246 mm
BAFFLE HOLE DIAMETER	420 mm	498 mm
BOLT MOUNT DIAMETER (PCD)	445 mm (8 Bolts)	550 × 520 mm
WEIGHT	25.10kg	36.80kg



PA Speakers - Neodymium

High power 12" low frequency speaker



N12-MB600X 600 WATTS

- High power Neodymium speaker for a variety of bass and mid range applications.
- Robust aluminium die-cast frame with heavy duty push terminals.
- 8.90 cm (3.5") CCAW I/O voice coil wound on Glass Fibre former to withstand high temperature.

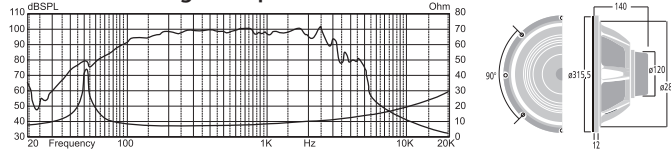

High power 12" low frequency speaker



N12-MB600Z 600 WATTS

- High power Neodymium speaker for a variety of bass and mid range applications.
- Robust aluminium die-cast frame with heavy duty push terminals.
- 8.90 cm (3.5") Copper I/O voice coil wound on Glass Fibre former to withstand high temperature.

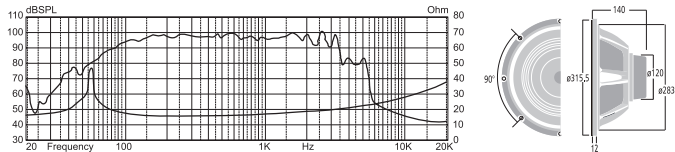

Super power 18" extended low frequency speaker



N18-SW1800 1800 WATTS

- Powerful and efficient Neodymium speaker with extended low frequency response.
- Robust aluminium die-cast frame with vents for efficient heat dissipation.
- 11.43 cm (4.5") Aluminium I/O voice coil wound on Glass Fibre former to withstand high temperature.

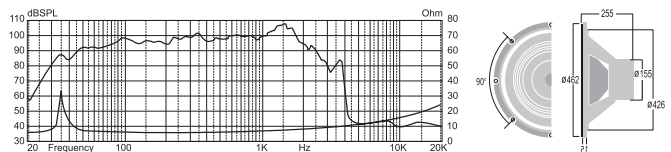

SPECIFICATIONS	N12-MB600X	N12-MB600Z	N18-SW1800
POWER RATING	600W RMS/1200W Programme	600W RMS/1200W Programme	1800W RMS/3600W Programme
NOMINAL DIAMETER	305 mm (12")	305 mm (12")	460 mm (18")
NOMINAL IMPEDANCE	8Ω	16Ω	8Ω
SENSITIVITY (1W/1m)	98dB	97dB	99dB
RESONANT FREQUENCY	(Fs) 52Hz	58Hz	35Hz
DC RESISTANCE	(Re) 7.18Ω	14.52Ω	5.6Ω
ELECTROMAGNETIC Q	(Qes) 0.27	0.45	0.22
MECHANICAL Q	(Qms) 10.6	11.9	14.63
TOTAL Q	(Qts) 0.26	0.43	0.21
COMPLIANCE EQUIVALENT VOLUME (VAS)	47.60Litr	50Litr	330Litr
SURFACE AREA OF CONE	(Sd) 564cm ²	564cm ²	1288cm ²
REFERENCE EFFICIENCY	(η ₁₀) 2.66%	2.11%	4.88%
VOICE COIL	3.5"	3.5"	4.5"
OVERHANG	(X _{max}) 7.0 mm	7.0 mm	18.0 mm
MOVING MASS	(M _{ms}) 76.80gm	66.25gm	170.6gm
BL PRODUCT	(BL) 22.18TM	25.41TM	28.6TM
COIL INDUCTANCE	(Le) 1.27mH	2.07mH	1.82mH
OVERALL DIAMETER	315.50 mm	315.50 mm	462 mm
DEPTH	140 mm	140 mm	255 mm
BAFFLE HOLE DIAMETER	283 mm	283 mm	428 mm
BOLT MOUNT DIAMETER	(PCD) 299 mm (8 Bolts)	299 mm (8 Bolts)	446 mm (8 Bolts)
WEIGHT	4.00kg	4.00kg	12.40kg



HD44-60T 60 WATTS

Professional compression driver HD44-60T, suitable for high power speakers. It features TITANIUM diaphragm round aluminium wire voice coil and strontium ferrite magnet for high SPL & superb HF response. With a suitable horn it is ideal for use with low frequency speakers AHUJA L12-MB300, L12-MB400, L15-MB300, L15-MB400 and L15-MB550.

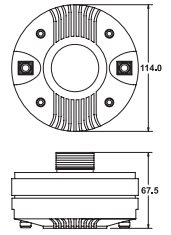

HD51-80T 80 WATTS

Professional compression driver HD51-80T, suitable for high power speakers. It features TITANIUM diaphragm round aluminium wire voice coil and strontium ferrite magnet for high SPL & superb HF response. With a suitable horn it is ideal for use with low frequency speakers AHUJA L12-MB400, L15-MB300, L15-MB400, L15-MB550, L15-MB700, N12-MB600X and N12-MB600Z.

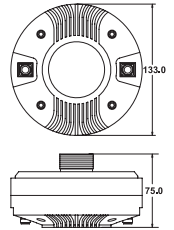

HD74-120 120 WATTS

Professional compression driver HD74-120, suitable for high power speakers. It features TITANIUM diaphragm copper clad aluminium ribbon wire voice coil and strontium ferrite magnet for high SPL & superb HF response. With a suitable horn it is ideal for use with low frequency speakers AHUJA L15-MB550, L15-MB700, L15-MB900, N12-MB600X and N12-MB600Z.

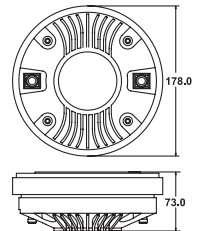

SPECIFICATIONS	HD44-60T	HD51-80T	HD74-120
POWER CAPACITY	60W RMS	80W RMS	120W RMS
THROAT DIAMETER	25.4 mm (1")	25.4 mm (1")	50 mm (2")
NOMINAL IMPEDANCE	8Ω	8Ω	8Ω
SENSITIVITY (1W/1m)	106dB (with Horn)	108dB (with Horn)	108dB (with Horn)
USABLE FREQUENCY RANGE	1,500-20,000Hz	1,000-20,000Hz	500Hz - 20,000Hz
RECOMMENDED CROSSOVER	2.5kHz, 18dB/Octave	2.5kHz, 18dB/Octave	1.2kHz, 18 dB/Octave
VOICE COIL DIAMETER	44.4 mm (1.74")	51.0 mm (2.0")	74.0 mm (2.91")
DIAPHRAGM MATERIAL	Titanium	Titanium	Titanium
VOICE COIL MATERIAL	Round Aluminium Wire	Round Aluminium Wire	CCAR Wire
VOICE COIL FORMER	Resin Bonded Kapton	Resin Bonded Kapton	Resin Bonded Kapton
THROAT COUPLING	1-3/8" 18TPI, Throat Couple No.1	1-3/8" 18TPI, Throat Couple No.1	—
OVERALL DIMENSIONS	Ø114 × H67.5 mm	Ø133 × H75 mm	Ø178 × H73 mm
WEIGHT	1.51kg	2.50kg	5.10kg

PA Horn Driver

CDH-200 20 WATTS

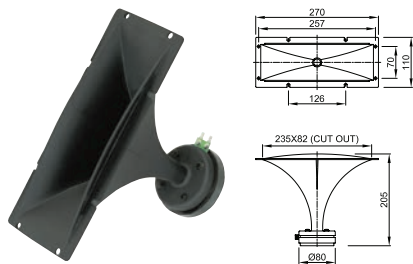

Professional compression driver-horn CDH-200 loudspeaker, is suitable for medium power speaker systems. It is ideal for use in a 200W to 300W system. Can be combined with a single Low Frequency speaker like AHUJA L12-MB200, L12-MB300 and L15-MB300, to make an excellent medium power full range speaker system.

SPECIFICATIONS	CDH-200
POWER CAPACITY	20W RMS
THROAT DIAMETER	25.4 mm (1")
NOMINAL IMPEDANCE	8Ω
SENSITIVITY (1W/1m)	105dB
USABLE FREQUENCY RANGE	3kHz-15kHz
RECOMMENDED CROSSOVER	4kHz 12dB/Octave
VOICE COIL DIAMETER	25.4 mm (1.0")
DIAPHRAGM MATERIAL	Phenolic Resin
VOICE COIL MATERIAL	Round Copper Wire
VOICE COIL FORMER	Nomex
HORN MATERIAL	ABS Glass Filled Polycarbonate
NOMINAL COVERAGE ANGLE	H100° x V80° (-5 dB)
HORN CUT OFF FREQUENCY	780Hz
MOUNTING CUTOUT	W235 × H82 mm
OVERALL DIMENSIONS	W270 × H110 × D205 mm
WEIGHT	1.36kg



PA Driver Diaphragms



Diaphragm HD44-60

- High quality diaphragm for compression driver HD44-60T. It features TITANIUM diaphragm, a precision-wound voice coil and sturdy push terminals.
- Rugged construction and reliable performance.
- Higher sensitivity and superb sound quality.
- Engineered with high performance components.



Diaphragm HD51-80

- High quality diaphragm for compression driver HD51-80T. It features TITANIUM diaphragm, a precision-wound voice coil and sturdy push terminals.
- Rugged construction and reliable performance.
- Higher sensitivity and superb sound quality.
- Engineered with high performance components.



Diaphragm HD74-120

- High quality diaphragm for compression driver HD74-120T. It features TITANIUM diaphragm, a precision-wound voice coil and sturdy push terminals.
- Rugged construction and reliable performance.
- Higher sensitivity and superb sound quality.
- Engineered with high performance components.

SPECIFICATIONS	HD44-60	HD51-80	HD74-120
POWER CAPACITY	60W RMS	80W RMS	120W RMS
NOMINAL IMPEDANCE	8Ω	8Ω	8Ω
VOICE COIL DIAMETER	44.4 mm (1.74")	51.0 mm (2.0")	74.0 mm (2.91")
DIAPHRAGM MATERIAL	Titanium	Titanium	Titanium
VOICE COIL MATERIAL	Round Aluminium Wire	Round Aluminium Wire	CCAR Wire
VOICE COIL FORMER	Resin Bonded Kapton	Resin Bonded Kapton	Resin Bonded Kapton

PA Piezo Horn Tweeters

AHUJA present a variety of compact and powerful piezo tweeters, driver and horn with extended high frequency response, low distortion and excellent power handling capacity. These are ideal for use with existing AHUJA range of 30.48 cm (12") and 38.1 cm (15") professional PA speakers.

APT-001

- Piezo tweeter.
- With horn front attachment for rear mounting.



APT-016

- Piezo tweeter.
- Compact rectangular form.



APT-025

- Rectangular high power piezo tweeter with deep low limit frequency



The piezo tweeters can be operated without a crossover network. However, it is recommended to connect a series resistor of about 20-50Ω (10-20W) or a metallised polyester capacitor of about 0.1-0.47mfd in order to avoid interfering effects and for proper matching of SPL levels with the woofer/full range speaker.

SPECIFICATIONS	APT-001	APT-016	APT-025
MAX. VOLTAGE	35V~	35V~	35V~
MUSIC POWER 4Ω/8Ω System	300W/ 150W	300W/ 150W	300W/ 150W
SPL (2.83V/1m)	94dB	91dB	92dB
FREQUENCY RESPONSE	4,000-20,000Hz	3,000-20,000Hz	1,800-20,000Hz
RADIATION ANGLE (V/H)	—	45°/90°	45°/90°
IMPEDANCE @ 1kHz	>1,000Ω	>1,000Ω	>1,000Ω
MOUNTING CUTOUT	73 mm	98 × 55 mm	155 × 58 mm
DIMENSIONS	85 × 85 mm	145 × 67 mm	187 × 80 mm
WEIGHT	65g	55g	100g

ACX-202 Active Crossover



A highly reliable, high performance 2 channel active crossover for use with the best cabinet speakers and subwoofers. Apart from top speakers in stereo mode, ACX-202 allows subwoofers to be connected in either stereo or mono mode.

- Full Stereo mode with Dual High & Low frequency outputs. Six selectable crossover frequencies. Extra sharp 24db / octave filter for very clear separation of frequency bands.
- Separate output for connecting subwoofer in mono mode, with 2 selectable crossover frequencies & 24db / octave filter.
- Separate input level controls for each channel, with LED indicator for clipping level.
- Phase Reversal Facility for Lo Outputs.
- XLR as well as TRS connectors for balanced inputs & outputs.

SPECIFICATIONS	ACX-202
INPUT SENSITIVITY	1V/20kΩ
LOW, HIGH OUT FILTER SLOPE	24dB/Oct
THD	<0.01%
CROSSOVER FREQUENCIES	For Stereo Mode: 60Hz, 80Hz, 100Hz, 120Hz, 180Hz, 250Hz / For Sub MONO Mode: 80Hz, 120Hz
FREQUENCY RANGE	20Hz to 20kHz
SIGNAL TO NOISE RATIO	85dB
INDICATIONS	Power ON LED, Clip LED
POWER SUPPLY	AC: 240V 50Hz
PROTECTION	AC: Fuse 1Amp. (T 1A L)
DIMENSIONS	W483 × H52 × D231 mm
WEIGHT	2.85kg

Passive Crossover

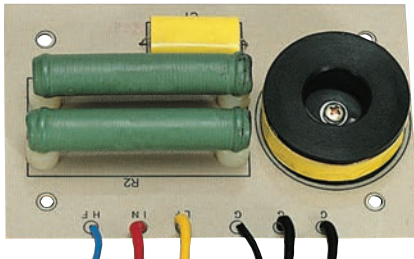

C-300/200 300W RMS

- Professional 2-Way Passive Crossover Network.
- Designed for use with 1 no. LF woofer AHUJA model L15-MB300, L12-MB300 or L12-MB200.
- HF horn driver CDH-200.
- High power and Low resistance Air core coils.
- High quality metallised polyester capacitors.

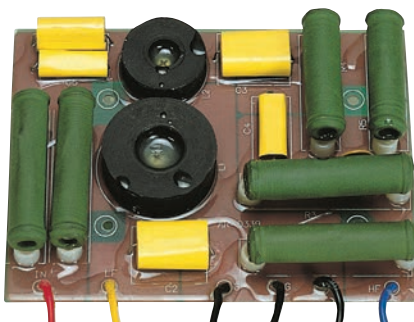

C-350/450 350W RMS

- Professional 2-Way Passive Crossover Network.
- Designed for use with 1 no. LF woofer AHUJA model L15-MB300 or L12-MB300.
- HF driver HD44-60T or HD51-80T.
- PTC for HF protection.
- High power and Low resistance Air core coils.
- High quality metallised polyester capacitors.

SPECIFICATIONS	C-300/200	C-350/450
TYPE	Two-Way Crossover	Two-Way Crossover
POWER CAPACITY	300W	350W
CROSSOVER FREQUENCY	4kHz	2kHz
NOMINAL IMPEDANCE	8Ω	8Ω
LOW PASS FILTER SLOPE	—	12dB/Octave
HIGH PASS FILTER SLOPE	12dB/Octave	18dB/Octave with protection
DIMENSIONS	W146 × H32 × D95 mm	W187 × H32 × D141 mm
WEIGHT	335g	630g



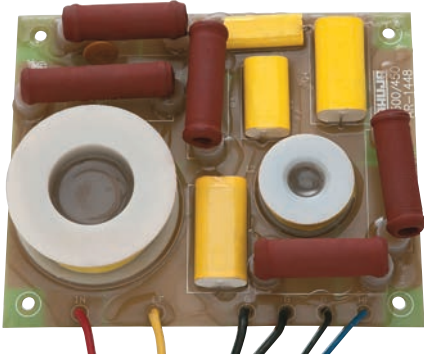

C-500/450 500W RMS

- Professional 2-Way Passive Crossover Network.
- Designed for use with 1no. LF woofer AHUJA model L15-MB400, L15-MB550 or L12-MB400.
- HF driver HD44-60T or HD51-80T.
- PTC for HF protection.
- High power and Low resistance Air core coils.
- High quality metallised polyester capacitors.

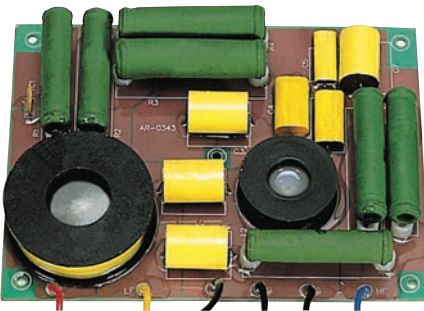

C-500/750 500W RMS

- Professional 2-Way Passive Crossover Network.
- Designed for use with 1 no. LF woofer AHUJA Model L15-MB550 or L12-MB400.
- HF driver HD74-120.
- PTC for HF protection.
- High power and Low resistance Air core coils.
- High quality metallised polyester capacitors.

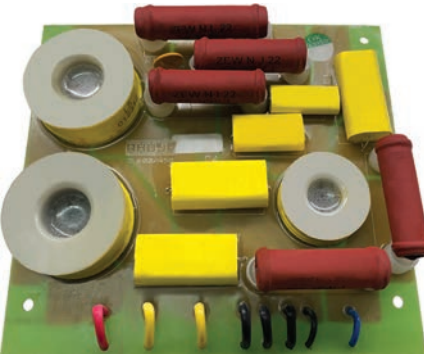

C-600/450 600W RMS

- Professional 2-Way Passive Crossover Network.
- Designed for use with 2 nos. LF woofer AHUJA Model L15-MB300 or L12-MB300.
- HF driver HD51-80T or HD74-120.
- PTC for HF protection.
- High power and Low resistance Air core coils.
- High quality metallised polyester capacitors.

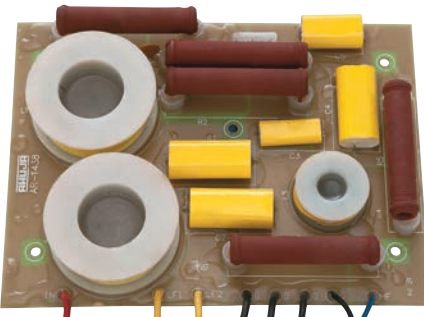

C-1000/450 1000W RMS

- Professional 2-Way Passive Crossover Network.
- Designed for use with 2 nos. LF woofer AHUJA model L15-MB400, L15-MB550 or L12-MB400.
- HF driver HD51-80T.
- PTC for HF protection.
- High power and Low resistance Air core coils.
- High quality metallised polyester capacitors.

SPECIFICATIONS	C-500/450	C-500/750	C-600/450	C-1000/450
TYPE	Two-Way Crossover	Two-Way Crossover	Two-Way Crossover	Two-Way Crossover
POWER CAPACITY	500W	500W	600W	1000W
CROSSOVER FREQUENCY	2.5kHz	1.2kHz	2.5kHz	2.5kHz
NOMINAL IMPEDANCE	8Ω	8Ω	4Ω	4Ω
LOW PASS FILTER SLOPE	12dB/Octave	12dB/Octave	12dB/Octave	12dB/Octave
HIGH PASS FILTER SLOPE	18dB/Octave with protection	18dB/Octave with protection	18dB/Octave with protection	18dB/Octave with protection
DIMENSIONS	W170 x H32 x D140 mm	W225 x H35 x D169 mm	W180 x H32 x D150 mm	W220 x H35 x D166 mm
WEIGHT	625g	1.11kg	805g	1.01kg

Passive Crossovers

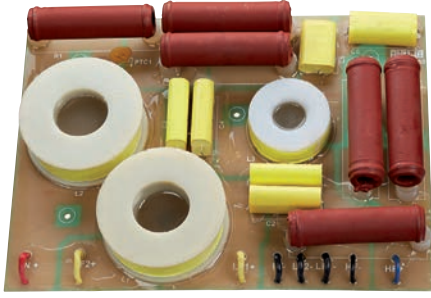

C-1300/750 1300W RMS

- Professional 2-Way Passive Crossover Network.
- Designed for use with 2 nos. LF woofer AHUJA Model L15-MB550 or L15-MB700.
- HF driver HD74-120.
- PTC for HF protection.
- High power and Low resistance Air core coils.
- High quality metallised polyester capacitors.

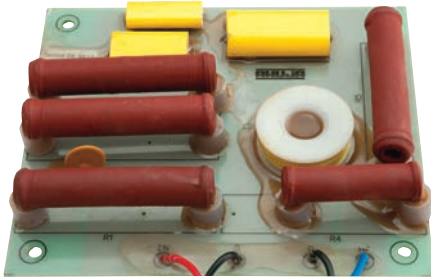

C-80HF 500W RMS

- Professional 1-Way Passive HF Crossover Network for HF Driver.
- Designed for use with 2-Way Speaker System using 1 no. compression driver AHUJA model HD51-80T.
- High power and Low resistance coils.
- High quality metallised polyester capacitors.

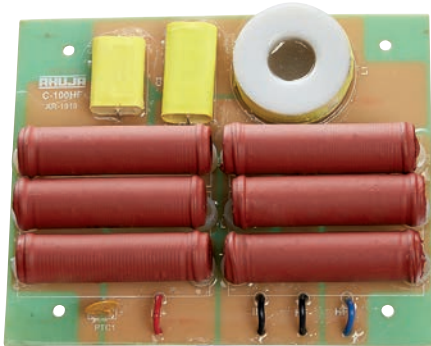

C-100HF 1300W RMS

- Professional 1-Way Passive HF Crossover Network for HF Driver.
- Designed for use with 2-Way Speaker System using 1 no. compression driver AHUJA model HD74-120.
- High power and Low resistance coils.
- High quality metallised polyester capacitors.

SPECIFICATIONS	C-1300/750	C-80HF	C-100HF
TYPE	Two-Way Crossover	HF Crossover	HF Crossover
POWER CAPACITY	1300W	500W	1300W
CROSSOVER FREQUENCY	1.2kHz	2.5kHz	1.2kHz
NOMINAL IMPEDANCE	4Ω	8Ω	8Ω
LOW PASS FILTER SLOPE	12dB/Octave	—	—
HIGH PASS FILTER SLOPE	18dB/Octave with protection	18dB/Octave with protection	18dB/Octave with protection
DIMENSIONS	W260 x H43 x D192 mm	W161 × H32 × D140 mm	W183 × H43 × D150 mm
WEIGHT	1.72kg	355g	622g



LMS-408

Loudspeaker Management System



Rear Panel

The LMS-408 is a premium 4 IN / 8 OUT Loudspeaker Management System. With multiple features and easy to use PC software, it provides the best sonic control over the speakers. Ideal for Live, Touring, Installations and PA Applications.

- 32-bit DSP, 48kHz sampling rate, 24bit AD/DA converter.
- Input settings include High-cut, Low-cut, 5 band PEQ, Noise gate, Gain, Mute, Phase and Link adjustment.
- Output settings include Crossover, 7 band PEQ, Gain, Mute, Compressor/Limiter, Phase, Delay and Link adjustment.
- Matrix selection for inputs and outputs each input and output channel name can be changed.
- High-cut, low-cut filter types can be selected as Butterworth, Link Witz-Riley, or Bessel with slopes from 6dB to 48dB/Octave.
- Compressor/limiter threshold, ratio, attack time and release time can be adjusted continuously for outputs.
- Delay time range is 680ms for output channels.
- Preset settings can be copied for every single channel. Linked channels will have automatic setting adjustment.
- Every input and output channel PEQ curve adjustment graph can be viewed in respective input/output channels.
- Built-in signal generator with Pink noise, White noise and 20 to 20kHz Sine wave.

SPECIFICATIONS	LMS-408
FREQUENCY RESPONSE	20Hz-20,000Hz, -0.3dBu
SIGNAL TO NOISE RATIO	>105 dBu
THD	<0.008 at 1kHz(0dBu)
CROSSTALK	>70dBu
INPUT	Balanced XLR
MAX. INPUT LEVEL	+15dBu
IMPEDANCE	20K/Stereo; 10K/MONO
OUTPUT	Balanced XLR
MAX. OUTPUT LEVEL	+15dBu
IMPEDANCE	<500Ω
DIGITAL PROCESSING	24-bit sigma-delta converters 48kHz Sampling Rates
DISPLAY	Dot matrix screen display
POWER SUPPLY	AC: 220-240V 50/60Hz
PROTECTION	AC: Fuse 1 × 2A (T 2A L)
DIMENSION	W482 × H44 × D210mm
WEIGHT	2.42 kg

85
YEARS+
SINCE 1940

Hallmark of Reliability!



Portable PA

Convenient, Compatible & Complete:

AHUJA Portable PA Equipment are attractive, ready to use amplifier and speaker all supplied in one integrated package.

Applications

Tour Guides | Traffic Police | Class Rooms | Mobile Announcements
Religious Discourses | Private Parties | Clubs & Community Centers

Bi-Amp PA Active Loudspeakers

ALIVE 515 500 WATTS



ALIVE 515 is Class D Bi-Amplifier Active Loudspeaker System designed for use in a wide variety of Professional and PA Programmes. Feature packed ALIVE 515 is an ideal equipment for applications such as in Professional Music and Vocal Performances, Touring PA, Mini-Theatres, Pubs and Bars, Religious Gatherings, Stage Monitors etc.

- Attractive Plastic moulded cabinet. Product designed for use in a wide variety of PA and Musical Instrument applications.
- Built-in DSP processor with presets; Music, DJ/Club, Live and Speech.
- Balanced XLR combo connector for MIC & LINE inputs.
- Balanced Line Output through XLR connector for easy connection of multiple ALIVE speakers.
- Active Bass/Mid/Treble controls for proper shaping of Low/Mid/High frequency levels.
- Built-in limiter which is tuned optimally for speaker protection.
- LIMIT indication in DSP for monitoring the output as well as caution against overdrive.
- Protection provided for output short and overdrive conditions.
- Built-in MP3 player with BT facility.

SPECIFICATIONS	ALIVE 515
POWER OUTPUT (Bi-AMP)	LF: 450W RMS at 1% THD Class D, HF: 50W RMS at 1% THD Class D
OUTPUT REGULATION	Better than 0.5dB
INPUT CHANNELS	INPUT-1: LINE Input 775mV through XLR combo or RCA, INPUT-2: MIC/Line switchable, MIC-15mV, line775mV
	MP3 player with built-in BT facility
FREQUENCY RESPONSE	50-20,000Hz \pm 3dB
DSP PROCESSOR	Built-in Preset Options: Speech, Music, Club/DJ, Live
SIGNAL TO NOISE RATIO	60dB
TONE CONTROLS	Bass: \pm 12dB, Mid \pm 12dB, Treble \pm 12dB
OUTPUT	Line Output - 775mV (through M/XLR)
PROTECTIONS	AC: Fuse 1 x 3.15A (T 3.15AL)
POWER SUPPLY	AC: 220-240V 50/60Hz
DIMENSIONS	W425 x H730 x D410 mm
WEIGHT	21.50 kg



ALIVE 512 500 WATTS



ALIVE 512 is Class D Bi-Amplifier Active Loudspeaker System designed for use in a wide variety of Professional and PA Programmes. Feature packed ALIVE 512 is an ideal equipment for applications such as in Professional Music and Vocal Performances, Touring PA, Mini-Theatres, Pubs and Bars, Religious Gatherings, Stage Monitors etc.

- Attractive Plastic moulded cabinet. Product designed for use in a wide variety of PA and Musical Instrument applications.
- Built-in DSP processor with presets; Music, DJ/Club, Live and Speech.
- Balanced XLR combo connector for MIC & LINE inputs.
- Balanced Line Output through XLR connector for easy connection of multiple ALIVE speakers.
- Active Bass/Mid/Treble controls for proper shaping of Low/Mid/High frequency levels.
- Built-in limiter which is tuned optimally for speaker protection.
- LIMIT indication in DSP for monitoring the output as well as caution against overdrive.
- Protection provided for output short and overdrive conditions.
- Built-in MP3 player with BT facility.

SPECIFICATIONS	ALIVE 512
POWER OUTPUT (Bi-AMP)	LF: 450W RMS at 1% THD Class D, HF: 50W RMS at 1% THD Class D
OUTPUT REGULATION	Better than 0.5dB
INPUT CHANNELS	INPUT-1: LINE Input 775mV through XLR combo or RCA, INPUT-2: MIC/Line switchable, MIC-15mV, line 775mV
	MP3 player with built-in BT facility
FREQUENCY RESPONSE	50-20,000Hz \pm 3dB
DSP PROCESSOR	Built-in Preset Options: Speech, Music, Club/DJ, Live
SIGNAL TO NOISE RATIO	60dB
TONE CONTROLS	Bass: \pm 12dB, Mid \pm 12dB, Treble \pm 12dB
OUTPUT	Line Output - 775mV (through M/XLR)
PROTECTIONS	AC: Fuse 1 x 3.15A (T 3.15AL)
POWER SUPPLY	AC: 220-240V 50/60Hz
DIMENSIONS	W365 x H615 x D350 mm
WEIGHT	18.10 kg



Bi-Amp PA Active Loudspeakers

ALIVE 510 300 WATTS



ALIVE 510 is Class D Bi-Amplifier Active Loudspeaker System designed for use in a wide variety of Professional and PA Programmes. Feature packed ALIVE 510 is an ideal equipment for applications such as in Professional Music and Vocal Performances, Touring PA, Mini-Theatres, Pubs and Bars, Religious Gatherings, Stage Monitors etc.

- Attractive Plastic moulded cabinet. Product designed for use in a wide variety of PA and Musical Instrument applications.
- Built-in DSP processor with presets; Music, DJ/Club, Live and Speech.
- Balanced XLR combo connector for MIC & LINE inputs.
- Balanced Line Output through XLR connector for easy connection of multiple ALIVE speakers.
- Active Bass/Mid/Treble controls for proper shaping of Low/Mid/High frequency levels.
- Built-in limiter which is tuned optimally for speaker protection.
- LIMIT indication in DSP for monitoring the output as well as caution against overdrive.
- Protection provided for output short and overdrive conditions.
- Built-in MP3 player with BT facility.

SPECIFICATIONS

ALIVE 510

POWER OUTPUT (Bi-AMP)	LF: 280W RMS at 1% THD Class D, HF: 20W RMS at 1% THD Class D
OUTPUT REGULATION	Better than 0.5dB
INPUT CHANNELS	INPUT-1: LINE Input 775mV through XLR combo or RCA, INPUT-2: MIC/Line switchable, MIC-15mV, Line775mV
	MP3 player with built-in BT facility
FREQUENCY RESPONSE	50-20,000Hz \pm 3dB
DSP PROCESSOR	Built-in Preset Options: Speech, Music, Club/DJ, Live
SIGNAL TO NOISE RATIO	60dB
TONE CONTROLS	Bass: \pm 12dB, Mid \pm 12dB, Treble \pm 12dB
OUTPUT	Line Output - 775mV (through M/XLR)
PROTECTIONS	AC: Fuse 1 x 3.15A (T 3.15AL)
POWER SUPPLY	AC: 220-240V 50/60Hz
DIMENSIONS	W330 x H575 x D310 mm
WEIGHT	13.45 kg

ABA-5000 400 WATTS



Rear Panel



ABA-5000 has a built-in Bi-Amplifier for woofer and HF driver separately, for use in a wide variety of Professional and PA Programmes. Feature packed ABA-5000 is an ideal equipment for applications such as in Professional Music and Vocal Performances, Touring PA, Mini-Theatres, Pubs and Bars, Religious Gatherings, Stage Monitors etc.

- 1 × Balanced Mic/Line Input selectable through a push switch.
- 1 × Line Input can be used for connecting balanced MONO signal through jack or unbalanced STEREO signal source through dual RCA.
- Switchable balanced output either as a Loop through output of Input-1 or a mix output of Input-1 and 2.
- Balanced output to link another ABA-5000 or for recording on a computer, record player.
- 2-Way Speaker System: 38.1 cm (15") LF Woofer Ø7.6 cm (3.0") voice coil + Dynamic Horn Ø4.4 cm (1.75") voice coil.
- Moulded Cabinet Bi-Amp PA Active Loudspeaker.

SPECIFICATIONS	ABA-5000
POWER OUTPUT (Bi-AMP)	LF: 350W RMS at 1% THD Class H, HF: 50W RMS at 1% THD Class AB
OUTPUT REGULATION	≤ 0.5dB, no load to full load at 1kHz
INPUT CHANNELS	INPUT-1: MIC 20mV/3kΩ balanced, LINE: 775mV/10kΩ balanced, INPUT-2: LINE (Jack) 250mV/20kΩ balanced, RCA: 250mV (L&R)/10kΩ
FREQUENCY RESPONSE	50-20,000Hz ±3dB
CROSSOVER FREQUENCY	2.5kHz, Filter Slope 24dB per octave
SIGNAL TO NOISE RATIO	60dB
TONE CONTROLS	Bass: ±5dB at 100Hz, Treble: ±5dB at 10kHz
OUTPUT	(a) Loop through (INPUT-1): 20mV or 775mV (b) Mixed Output (1+2): 775mV/1kΩ
PROTECTIONS	AC: Fuse 1 × 5A (T 5A L) DC: Fuse 2 × 8A (T 8A L)
POWER SUPPLY	AC: 220-240V 50/60Hz
AC POWER CONSUMPTION	500VA
DIMENSIONS	W450 × H690 × D360 mm
WEIGHT	28.10kg



Bi-Amp PA Active Loudspeakers

ABA-4000 325 WATTS



Rear Panel



ABA-4000 has a built-in Bi-Amplifier for woofer and HF driver separately, for use in a wide variety of Professional and PA Programmes. Feature packed ABA-4000 is an ideal equipment for applications such as in Professional Music and Vocal Performances, Touring PA, Mini-Theatres, Pubs and Bars, Religious Gatherings, Stage Monitors etc.

- 1 × Balanced Mic/Line Input selectable through a push switch.
- 1 × Line Input can be used for connecting balanced MONO signal through jack or unbalanced STEREO signal source through dual RCA.
- Switchable balanced output either as a Loop through output of Input-1 or a mix output of Input-1 and 2.
- Balanced output to link another ABA-4000 or for recording on a computer, record player.
- 2-Way Speaker System: 30.4 cm (12") LF Woofer Ø6.3 cm (2.5") voice coil + Dynamic Horn Ø4.4 cm (1.75") voice coil).
- Moulded Cabinet Bi-Amp PA Active Loudspeaker.

SPECIFICATIONS	ABA-4000
POWER OUTPUT (Bi-AMP)	LF: 275W RMS at 1% THD Class H, HF: 50W RMS at 1% THD Class AB
OUTPUT REGULATION	≤ 0.5dB, no load to full load at 1kHz
INPUT CHANNELS	INPUT-1: MIC 20mV/3kΩ balanced, LINE: 775mV/10kΩ balanced, INPUT-2: LINE (Jack) 250mV/20kΩ balanced, RCA: 250mV (L&R)/10kΩ
FREQUENCY RESPONSE	50-20,000Hz ±3dB
CROSSOVER FREQUENCY	2kHz, Filter Slope 24dB per octave
SIGNAL TO NOISE RATIO	60dB
TONE CONTROLS	Bass: ±5dB at 100Hz, Treble: ±5dB at 10kHz
OUTPUT	a) Loop through (INPUT-1): 20mV or 775mV b) Mixed Output (1+2): 775mV/1kΩ
PROTECTIONS	AC: Fuse 1 × 4A (T 4A L) DC: Fuse 2 × 6A (T 6A L)
POWER SUPPLY	AC: 220-240V 50/60 Hz
AC POWER CONSUMPTION	375VA
DIMENSIONS	W385 × H585 × D305 mm
WEIGHT	20.80kg

XPA-1520DP

175 WATTS



XPA-1520DP is a Bi-Amp Active Loudspeaker System with multiple inputs for use in a wide variety of PA and Musical Programmes. Feature packed XPA-1520DP is an ideal equipment for small as well as medium gatherings of around 100 people. Applications include Music and Vocal Performances, Conferences and Lectures, Presentations, Religious Discourses and Gatherings, Stage Monitors, Touring PA, Mini-Theatres, Pubs and Bars etc.

- Built-in Class-D Bi-Amplifier for LF and HF drivers.
- Two Wired Mic inputs, Two Wireless Mics & One Aux input.
- Built-in 25.4 cm (10") LF Woofer Ø5.0 cm (2.0") voice coil + Dynamic Horn Ø2.5 cm (1.0") voice coil & HF Tweeter.
- Mic-1 and Wirelsss Mics have selectable priority over all other inputs.
- Built-in MP3 Player with Bluetooth, Recorder and remote control. Built-in Digital Echo Effects. Built-in TWS & Sing Along feature..
- Active Bass & Treble controls for desired tonal shaping. LED indications for ON, FAULT, CLIP level.

SPECIFICATIONS	AMPLIFIER
POWER OUTPUT (Bi-AMP)	LF: 125W RMS at 1% THD, HF: 50W RMS at 1% THD
OUTPUT REGULATION	≤ 0.5dB, no load to full load at 1kHz
INPUT CHANNELS	2 × Mic 5mV/4.7kΩ, 1 × Aux 200 mV/47kΩ, 2 × Wireless MIC, 1 × Line Input 1.2V
FREQUENCY RESPONSE	50-20,000Hz ±3dB
CROSSOVER FREQUENCY	2.5kHz, Filter Slope 24dB per Octave
SIGNAL TO NOISE RATIO	60dB
TONE CONTROLS	BASS: ±5dB at 100Hz, TREBLE: ±5dB at 10kHz
LINE OUTPUT	775mV
DIGITAL PLAYER	MP3 player with USB, SD, MMC Card Reader, Recording Function and Bluetooth.
PROTECTIONS	AC: Fuse 1 × 3.15A (T 3.15A L)
POWER SUPPLY	AC: 220-240V 50/60Hz
AC POWER CONSUMPTION	200VA
WIRELESS RECEIVING MODE	Quartz Controlled Fixed Frequency
WIRELESS RANGE	Over 20m in Free Space (Line of Sight)
DIMENSIONS	W325 × H485 × D255 mm
WEIGHT	11.30kg

SPECIFICATIONS	TRANSMITTER
RF OUTPUT POWER	15mW (Max.)
FREQUENCY RESPONSE	50-15,000Hz
BATTERY	3V (2 × 1.5V AA Pencil Cells)
DIMENSION	Ø55 (L 248) mm
WEIGHT	180g (without battery)



BTA-1010 90 WATTS



- Class D Bi-amplifier featuring attractive, elegant and stylish looking cabinet with Trolley System.
- Two Mic inputs, Two Wireless Mics, one Aux input & one Music input.
- Built-in 38.1 cm (15") 8 Ω speaker with dual voice coil & 8 Ω HF driver.
- Mic 1 has selectable priority over all other inputs.
- Built-in MP3 player with Bluetooth, Recorder, SD card and Remote Control.
- Built-in Digital Echo effects.
- Active Bass & Treble controls for setting the desired tonal quality.
- LED indications for low battery, charging & clip output.
- Facility of Auto cut-off to prevent battery from deep discharge.
- Three power source operation AC mains, External 12V DC or built-in 12V 9Ah rechargeable battery.

SPECIFICATIONS	AMPLIFIER
AUDIO OUTPUT (BI-AMP)	90W Max.
INPUT CHANNELS	2 \times Mic 3mV/4.7k Ω , 1 \times Aux 100 mV/47k Ω , Music 100mV/47k Ω , 2 \times Wireless MIC
PREAMP OUTPUT	200mV/600 Ω
TONE CONTROLS	Bass \pm 5dB at 100Hz, Treble \pm 5dB at 10kHz
DIGITAL PLAYER	MP3 player with USB, SD, MMC card reader, Recording function and Bluetooth.
POWER REQUIREMENTS	AC : 220V-240V 50/60Hz, DC : 12V Car Battery (external), 12V 9Ah Rechargeable Battery (built-in)
POWER CONSUMPTION	170VA
PROTECTION	AC Fuse: 1A 250V (T 1A L)
WIRELESS RECEIVING MODE	Quartz Controlled Fixed Frequency
WIRELESS RANGE	Over 20m in Free Space (Line of Sight)
DIMENSION	W440 \times H700 \times D350 mm
WEIGHT	18.80kg

SPECIFICATIONS	TRANSMITTER
RF OUTPUT POWER	10mW (Max.)
MAX. MODULATION	45dB
FREQUENCY RESPONSE	50-15,000Hz
BATTERY	3V (2 \times 1.5V AA Pencil Cells)
DIMENSION	\varnothing 52 \times L242 mm
WEIGHT	140g (w/o battery)

ASPIRE-208

55 WATTS



- Elegant and stylish looking plastic moulded cabinet with Trolley System.
- Two Mic inputs, Two Wireless Mics, one Aux input & one Music input. Built-in Digital Echo.
- Built-in dual 203.2 mm (8") speakers & HF driver. Active Bass & Treble controls for setting the desired tonal quality.
- Built-in MP3 Player with Bluetooth, Recorder, SD Card and remote control. Mic 1 has selectable priority over all other inputs.
- LED indications for low battery, charging & clip output. Facility of auto cut-off to prevent battery from deep discharge.
- Three power source operation AC mains, External 12V DC and built-in 12.8V 4500mAh Li-ion rechargeable battery.

SPECIFICATIONS	AMPLIFIER
AUDIO OUTPUT	55W Max.
INPUT CHANNELS	2 × Mic 3mV/4.7kΩ, 1 × Aux 100mV/47kΩ, Music 100mV/47kΩ, 2 × Wireless MIC
PREAMP OUTPUT	200mV/600Ω
TONE CONTROLS	Bass ±5dB at 100Hz, Treble ±5dB at 10kHz
DIGITAL PLAYER	MP3 player with USB, SD, MMC card reader, Recording function and Bluetooth
POWER REQUIREMENTS	AC : 220V-240V 50/60Hz, DC : 12V Car Battery (external), 12.8V, 4500mAh Rechargeable Li-ion battery (built-in)
POWER CONSUMPTION	60VA
PROTECTION	AC Fuse: 1 Amp. 250V (T 1A L)
WIRELESS RECEIVING MODE	Quartz Controlled Fixed Frequency
WIRELESS RANGE	Over 20m in Free Space (Line of Sight)
DIMENSION	W340 × H680 × D300 mm
WEIGHT	14.60kg

SPECIFICATIONS	TRANSMITTER
RF OUTPUT POWER	10mW (Max.)
MAX. MODULATION	45dB
FREQUENCY RESPONSE	50-15,000Hz
BATTERY	3V (2 × 1.5V AA Pencil Cells)
DIMENSION	Ø52 × (L 242) mm
WEIGHT	140g (without battery)



BTA-880® 50 WATTS



- Elegant and stylish looking plastic moulded cabinet PA Amplifier Set with Trolley System.
- Two Mic inputs, Two Wireless Mics, one Aux input & one Music input. Mic1 has selectable priority over all other inputs.
- Built-in 30.4 cm (12") 4Ω speaker & 8Ω HF driver.
- Built-in MP3 Player with Bluetooth, Recorder, SD Card and Remote Control. Built-in Digital Echo effects.
- Tone control for setting the desired tonal quality.
- LED indications for low battery, charging & clip output. Auto cut-off feature prevents deep discharge of rechargeable battery.
- Operates on AC mains, external 12V DC or built-in 12V 7Ah rechargeable battery.

SPECIFICATIONS	AMPLIFIER
AUDIO OUTPUT (BI-AMP)	50W Max.
INPUT CHANNELS	2 × Mic 3mV/4.7kΩ, 1 × Aux 100 mV/47kΩ, Music 100mV/47kΩ, 2 × Wireless MIC
PREAMP OUTPUT	200mV/600Ω
TONE CONTROLS	Bass ±5dB at 100Hz, Treble ±5dB at 10kHz
DIGITAL PLAYER	MP3 player with USB, SD, MMC card reader, Recording function and Bluetooth.
POWER REQUIREMENTS	AC : 220V-240V 50/60Hz DC : 12V Car Battery (external), 12V 7Ah Rechargeable Battery (built-in)
POWER CONSUMPTION	60VA
PROTECTION	AC Fuse: 1A 250V (T 1A L)
WIRELESS RECEIVING MODE	Quartz Controlled Fixed Frequency
WIRELESS RANGE	Over 20m in Free Space (Line of Sight)
DIMENSION	W405 × H610 × D350 mm
WEIGHT	18.80kg
SPECIFICATIONS	TRANSMITTER
RF OUTPUT POWER	10mW (Max.)
MAX. MODULATION	45dB
FREQUENCY RESPONSE	50-15,000Hz
BATTERY	3V (2 × 1.5V AA Pencil Cells)
DIMENSION	Ø52 × L242 mm
WEIGHT	140g (w/o battery)

BTA-660®M

40 WATTS



- Elegant and stylish looking plastic moulded cabinet PA Amplifier Set with Trolley System.
- Two Mic inputs, Two Wireless Mics, one Aux input & one Music input. Mic1 has selectable priority over all other inputs.
- Built-in 25.4 cm (10") 4Ω speaker & 8Ω HF driver.
- Built-in MP3 Player with Bluetooth, Recorder, SD Card and Remote Control. Built-in Digital Echo effects.
- Tone control for setting the desired tonal quality.
- LED indications for low battery, charging & clip output. Auto cut-off feature prevents battery deep discharge.
- Operates on AC mains, external 12V DC or built-in 12V 7Ah rechargeable battery.

SPECIFICATIONS	AMPLIFIER
AUDIO OUTPUT (BI-AMP)	40W Max.
INPUT CHANNELS	2 × Mic 4mV/4.7kΩ, 1 × Aux 100 mV/47kΩ, Music 100mV/47kΩ, 2 × Wireless MIC
PREAMP OUTPUT	200mV/600Ω
TONE CONTROLS	Bass ±5dB at 100Hz, Treble ±5dB at 10kHz
DIGITAL PLAYER	MP3 player with USB, SD, MMC card reader, Recording function and Bluetooth.
POWER REQUIREMENTS	AC : 220V-240V 50/60Hz DC : 12V Car Battery (external), 12V 7Ah Rechargeable Battery (built-in)
POWER CONSUMPTION	50VA
PROTECTION	AC Fuse: 1A 250V (T 1A L)
WIRELESS RECEIVING MODE	Quartz Controlled Fixed Frequency
WIRELESS RANGE	Over 20m in Free Space (Line of Sight)
DIMENSION	W325 × H550 × D280 mm
WEIGHT	14.30kg
SPECIFICATIONS	TRANSMITTER
RF OUTPUT POWER	10mW (Max.)
MAX. MODULATION	45dB
FREQUENCY RESPONSE	50-15,000Hz
BATTERY	3V (2 × 1.5V AA Pencil Cells)
DIMENSION	Ø52 × L242 mm
WEIGHT	140g (without battery)



BTA-550 30 WATTS



- Elegant and compact Portable PA Amplifier in plastic moulded cabinet with trolley system.
- Two Mic inputs, one Wireless Mic & one Aux (Guitar) input.
- Built-in 20.32 cm (8") 30W Full Range Dual Cone speaker & a tweeter.
- Mic-1 and Wireless Mic have selectable priority over all other inputs.
- Built-in MP3 Player with Bluetooth, Recorder and remote control.
- Built-in Digital Echo.
- Active Bass & Treble controls.
- LED indications for low battery, charging & clip output.
- Facility of auto cut-off to prevent battery from deep discharge.
- Three power source operation (AC mains, External 12V DC or built-in 11.1V 2200mAh rechargeable Li-ion battery).

SPECIFICATIONS	AMPLIFIER
AUDIO OUTPUT	30W Max.
INPUT CHANNELS	2 × Mic 4mV/4.7kΩ, 1 × Aux 100mV/47kΩ, 1 × Wireless MIC
LINE OUTPUT	775mV
TONE CONTROLS	Bass ±5dB at 100Hz, Treble ±5dB at 10kHz
DIGITAL PLAYER	MP3 player with USB, MMC/TF card reader, Recording function and Bluetooth.
POWER REQUIREMENTS	AC : 220V-240V 50/60Hz, DC : 12V Car Battery (external), 11.1V 2200mAh Rechargeable Li-ion battery (built-in)
POWER CONSUMPTION	50VA
PROTECTION	AC Fuse: 1 Amp. 250V (T 1A L)
WIRELESS RECEIVING MODE	Quartz Controlled Fixed Frequency
WIRELESS RANGE	Over 20m in Free Space (Line of Sight)
DIMENSION	W260 × H400 × D220 mm
WEIGHT	5.60kg

SPECIFICATIONS	TRANSMITTER
RF OUTPUT POWER	15mW (Max.)
FREQUENCY RESPONSE	50-15,000Hz
BATTERY	3V (2 × 1.5V AA Pencil Cells)
DIMENSION	∅55 (L 248) mm
WEIGHT	180g (without battery)

WP-225 / WP-225L
20 WATTS



WP-225
(Handheld Transmitter)



Lavalier Mic

Headband Mic

WP-225L
(Bodypack Transmitter)

A truly portable, highly versatile and attractive 20 Watts Max. PA Wireless Amplifier Set. Ideal for various Indoor and Outdoor applications such as Small Gatherings, Presentations, Performances, Bus Tours, Classrooms etc.,

- Elegant, rugged & easy to carry amplifier which delivers 20W (max.) output power. Built-in digital MP3 player with recording and Bluetooth function.
- WP-225 is supplied with a Handheld wireless transmitter.
- WP-225L consists of a Bodypack transmitter with a Headband Mic and a Lavalier Mic.
- Provision for connecting one wired microphone through 6.3 mm jack plug & an AUX source like a CD player or Mixer using 3.5 mm phone jack.
- Priority available for both wireless & wired mic, selectable through an ON/OFF switch.
- Tone control provided for adjusting the frequency response.
- Operates on AC mains, 12V external car battery & 11.1V 2200mAh internal rechargeable lithium battery.
- Facility for recharging a 11.1V 2200mAh Li-ion battery is provided alongwith a charging LED indicator.
- Built-in digital echo.
- 8 Ohm external speaker output.

SPECIFICATIONS	AMPLIFIER
AUDIO OUTPUT	20W Max.
INPUT CHANNELS SENSITIVITY	Mic 6mV, Aux 200mV
AUX OUTPUT	400mV
USB/SD PLAYER	MP3 format
POWER REQUIREMENTS	AC 220-240V, 50/60Hz, DC 12-14V Car Battery, 11.1V 2200mAh Rechargeable Li-ion Battery (built-in)
POWER CONSUMPTION	35VA
WIRELESS RECEIVING MODE	Quartz Controlled Fixed Frequency
WIRELESS RANGE	Over 20m in Free Space (Line of Sight)
DIMENSION	W207 × H292 × D145 mm
WEIGHT	2.00kg

SPECIFICATIONS	HANDHELD TRANSMITTER	BODYPACK TRANSMITTER
RF OUTPUT POWER	10mW (Max.)	10mW (Max.)
MAX. MODULATION	45dB	45dB
FREQUENCY RESPONSE	50-15,000Hz	50-15,000Hz
BATTERY	3V (2 × 1.5V AA Pencil Cells)	3V (2 × 1.5V AA Pencil Cells)
DIMENSION	Ø52 × L250 mm	W65 × H108 × D30 mm
WEIGHT	150g (without battery)	70g (without battery)



PA Amplifier Sets



NBA-20DP

12 WATTS ■ Neckband PA Amplifier Set

- Elegant and compact ultra portable PA Amplifier Set with max. output power of 12W.
- Built-in MP3 digital player for playback of music through a USB drive or a TF card.
- Special circuitry provides low distortion even at high output power. Built-in high capacity rechargeable battery. Low battery LED indicator.
- Ø3.5 mm Mic input socket for connecting the headband microphone and 3.5 mm Line input socket for connecting a DVD, CD or an MP3 player.
- Apart from the headband mic provided, the mic input socket can also accept input from Ahuja Condenser Microphones CTP-10DX, UTP-30 (used without their cell compartment).
- Convenience of use. The unit can be used while hanging on the shoulder or by putting around the neck.
- 5V Adaptor provided alongwith.
- Ideal for: Teaching, Tour Guides, Yoga Classes, Play Schools etc. ...



NBA-15

12 WATTS ■ Neckband PA Amplifier Set

- Elegant and compact ultra portable PA Amplifier Set with max. output power of 12W.
- Special circuitry provides low distortion even at high output power. Built-in high capacity rechargeable battery. Low battery LED indicator.
- Ø3.5 mm Mic input socket for connecting the headband microphone and 3.5 mm Line input socket for connecting a DVD, CD or an MP3 player.
- Convenience of use. The unit can be used while hanging on the shoulder or by putting around the waist.
- 5V Adaptor provided alongwith.
- Ideal for: Teaching, Tour Guides, Yoga Classes, Play Schools etc. ...



NBA-112B

10 WATTS ■ Neckband PA Amplifier Set



- Elegant and compact ultra portable PA Amplifier Set with max. output power of 10W.
- Special circuitry provides low distortion even at high output power. Built-in high capacity rechargeable battery. Low battery indicated by a voice prompt.
- Ø3.5 mm Mic input socket for connecting the headband microphone.
- Mode button for selecting bluetooth function.
- Convenience of use. The unit can be used while hanging on the shoulder or by putting around the waist.
- Supplied with USB charging cable.
- Ideal for: Teaching, Tour Guides, Yoga Classes, Play Schools etc. ...

SPECIFICATIONS	NBA-20DP	NBA-15	NBA-112B
POWER OUTPUT	12W Max.	12W Max.	10W Max.
SPEAKER IMPEDANCE	4Ω	4Ω	2Ω
INPUT CHANNEL	Mic-1: 1.0mV, Line: 250mV	Mic-1: 1.0mV, Line: 250mV	Mic: 1.0mV, Bluetooth
DIGITAL PLAYER	USB & TF Card (16GB max.)	—	—
FREQUENCY RESPONSE	80-12,000Hz	80-12,000Hz	180-18,000Hz
RECHARGEABLE BATTERY	3.7V, 2000mAh	3.7V, 2000mAh	3.7V, 1800mAh
HEADBAND MICROPHONE ELEMENT	Condenser, Unidirectional	Condenser, Unidirectional	Condenser, Unidirectional
DIMENSIONS (amplifier only)	W86 × H98 × D44 mm	W86 × H98 × D44 mm	W110 × H83 mm × D53 mm
WEIGHT (with rechargeable battery)	340g (amplifier only)	340g (amplifier only)	256g (amplifier only)

VIVA-600

525 WATTS



Compact and elegant Class-D Bi-Amp Active Loudspeakers with 400W RMS for LF and 125W RMS for HF. Built-in preset equalizer with NORMAL, JAZZ, CLASSIC, & POP modes. Ideal for indoor live music performances and small gatherings.

- High quality class D amplifier with digital processor.
- Equalizer setting of NORMAL mode has provision to cut & boost gain for 5 frequencies 80Hz, 330Hz, 1.2kHz, 3.3kHz & 12kHz.
- Integrated satellite 3x cylindrical speaker columns, directly fittable on Subwoofer cabinet without hassle of speaker wiring.
- Rear panel control consists of LCD digital display to view & set the features in use.
- Built-in Bluetooth for playing music.
- 2 × combo input connectors (TRS/XLR) for Mic or Line input.
- Built-in fixed limiter: 6dB for LF & 18dB for HF provided for protection.
- Ease of operation combined with service accessibility has been optimized in design.



SPECIFICATIONS	VIVA-600	
	LF	HF
POWER OUTPUT	400W RMS at < 1% THD	125W RMS at < 1% THD
SENSITIVITY	Line: 450mV	450mV
	Mic: 10mV	10mV
OUTPUT	XLR Mixed Output	
EQUALIZER	NORMAL, CLASSIC, JAZZ, POP	
LIMITER	6dB	18dB
SETTING FOR NORMAL EQ.	EQ.-1 80Hz : -8dB to +3dB, EQ.-2 330Hz : -8dB to +5dB, EQ.-3 1.2kHz : -8dB to +5dB, EQ.-4 3.3kHz : -8dB to +5dB, EQ.-5 12kHz : -8dB to +5dB	
SPEAKER	304.8 mm (12") Subwoofer	8 × 76.2 mm (3") Speaker
FREQUENCY RESPONSE	30Hz-160Hz	160Hz-20kHz
MP3 PLAYBACK	Via Bluetooth	
SIGNAL TO NOISE RATIO	80dB	
POWER SUPPLY	AC : 220-240V 50/60Hz	
PROTECTION	AC: Fuse 3.15Amp.	
AC POWER CONSUMPTION	650 VA	
DIMENSIONS	Subwoofer: W385 × H485 × D520 mm, Satellite (Top): W85 × H495 × D112 mm,	
	Satellite (Mid. & Bottom): W85 × H515 × D112 mm	
WEIGHT	Subwoofer: 20.80kg, Satellite: 1.30+1.30+1.10kg	



ASL-3000R

90 WATTS PA Amplifier Set

- Compact, reliable and easy-to-assemble Public Address Lectern System with built-in 90W Class D amplifier.
- Supplied with a 460 mm (18") detachable gooseneck condenser microphone and a reading light, for the podium top.
- Contains a built-in Dual Channel VHF wireless receiver and two nos. of VHF compatible wireless handheld transmitters in five different pairs of fixed frequency.
- Fitted with 3 nos. of 165 mm (6.5") coated dual cone speakers. Provision given for connecting an external speaker, through a 6.3 mm (1/4") phone plug and INT./EXT. selector switch.
- Facility for connecting an auxiliary source through a 6.3 mm (1/4") phone plug.
- Built-in digital MP3 recording, playback and Bluetooth facility. Recording or playback can be done using either a USB pen drive or a SD card. Remote for MP3 recorder is supplied along with.
- Output connector for MIX OUT, through a 6.3 mm (1/4") phone socket, allowing the lectern system to be connected to external amplifiers for further amplification, if required.
- 2 Handheld wireless transmitter & gooseneck podium microphone have voice priority over all other inputs. This feature can be switched ON or OFF through a slide switch.
- USB outlet on podium top for charging of Mobile phones.



SPECIFICATIONS	RECEIVER AMPLIFIER
POWER OUTPUT	90 Watts Max; 60 Watts Rated
SPEAKER IMPEDANCE (External)	4Ω to 8Ω
INPUT CHANNELS SENSITIVITY	Mic-1(Gooseneck Mic): 8mV, Mic-2: 5mV Line: 100mV, Aux : 200mV
FREQUENCY RESPONSE	50-16,000Hz
TONE CONTROL	Bass ±5dB at 100Hz, Treble ±5dB at 10kHz
POWER SUPPLY	AC 220-240V, 50/60Hz
POWER CONSUMPTION	AC 100VA
DIMENSIONS	W580 × H1150 × D420 mm
WEIGHT	18.20kg

SPECIFICATIONS	HANDHELD WIRELESS TRANSMITTER
MICROPHONE	Dynamic, Cardioid
RF OUTPUT POWER	15mW (max.)
FREQUENCY RESPONSE	50-15,000Hz
BATTERY	3V (2x1.5V AA Pencil Cells)
DIMENSIONS	Ø55 × L248 mm
WEIGHT	180g (without battery)

AM-25DPM

25 WATTS ■ Shoulder Sling & Hand Grip Type

- UM-3 (AA) Pencil Cells & Car Battery (12-14V DC) operation.
- Can also operate on Li-ion Battery.
- Class-D Amplifier provides extremely high efficiency of power consumption resulting in extended battery life.
- All ABS body, sturdy yet lightweight.
- Built-in Siren.
- Clear sound, long range & efficient.
- Microphone with Volume Control & built-in recording / playback facility.
- Message upto 240 seconds (4minutes) can be recorded.
- MP3 playback through USB, SD/MMC card, Aux input & Bluetooth.
- Can be used as hand held as well as on shoulder.
- Recommended to use AA Alkaline Cell or Li-ion battery for extended life and better performance.

AM-22HSD

28 WATTS ■ Shoulder Sling & Hand Grip Type

- UM-3 (AA) Pencil Cells & Car Battery (12-14V DC) operation.
- Can also operate on Li-ion Battery.
- Class-D Amplifier provides extremely high efficiency of power consumption resulting in extended battery life.
- Uses larger voice coil and bigger magnet assembly for higher SPL.
- All ABS body, sturdy yet lightweight.
- Built-in Siren.
- Clear sound, long range & efficient.
- Microphone with Volume Control & Press-to-Talk Switch.
- Can be used as hand held as well as on shoulder.
- Recommended to use AA Alkaline Cell or Li-ion battery for extended life and better performance.

AM-30SS

30 WATTS ■ Shoulder Sling & Hand Grip Type

- UM-3 (AA) Pencil Cells & Car Battery (12-14V DC) operation.
- Can also operate on Li-ion Battery.
- Class-D Amplifier provides extremely high efficiency of power consumption resulting in extended battery life.
- Uses larger voice coil and bigger magnet assembly for higher SPL.
- All ABS body, sturdy yet lightweight. Clear sound, long range & efficient. Can be used as hand held as well as on shoulder.
- Built-in THREE LEVEL SIREN with selector switch.
- Suitable for Petroleum and Natural Gas Regulatory Board (PNGRB)-Emergency Response & Disaster Management Plan (ERDMP) Regulations.
- Microphone with Volume Control & Press-to-Talk Switch.
- Recommended to use AA Alkaline Cell or Li-ion battery for extended life and better performance.



CLASS D



CLASS D



CLASS D

SPECIFICATIONS	AM-25DPM	AM-22HSD	AM-30SS
POWER OUTPUT	20W Rated / 25W Max	22W Rated / 28W Max.	25 Rated / 30W Max.
VOICE RANGE	Approx. 400m (Siren 500m) In Quiet Surroundings	Approx. 400m (Siren 500m) In Quiet Surroundings	Approx. 400m (Siren 500m) In Quiet Surroundings
POWER SOURCE	10 × AA Pencil Cells /Car Battery 12-14V DC 11.1V Li-ion Battery (optional)	10 × AA Pencil Cells /Car Battery 12-14V DC 11.1V Li-ion Battery (optional)	10 × AA Pencil Cells /Car Battery 12-14V DC 11.1V Li-ion Battery (optional)
MICROPHONE	Unidirectional	Unidirectional	Unidirectional
INPUTS	Dedicated Microphone	Dedicated Microphone	Dedicated Microphone
DIMENSIONS	Horn Ø230mm, L382 mm	Horn Ø220mm, L370 mm	Horn Ø220mm, L370 mm
WEIGHT	1.20kg (without cells)	1.90kg (without cells)	1.90kg (without cells)



CCS-2300

AC Operation



CCS-2300, a two-way counter communication system, exclusively designed for easy and effective conversation across counters with transparent security barriers. It consists of an attendant unit, a customer unit and a power supply unit, which are easy to install and simple to connect through dedicated cables as supplied with the system.

- Unique design, pleasing aesthetics & rugged construction.
- Two-way, hands-free communication.
- Easy, hassle-free installation.
- Compact & elegant table top attendant unit with 508 mm (20") long gooseneck microphone for strain-free usage.
- A 3.5 mm jack socket is provided for connecting a headband microphone like Ahuja HBM-50. This is useable by the attendant as an alternate to the fixed gooseneck microphone.
- Separate controls for adjusting the speech levels during Talk & Listen modes of operation.
- Special Auto-Mute ON/OFF option provided through a toggle switch. In Auto-Mute ON condition, the customer's microphone is partially muted if it is not used for 30 sec. approx. This facility prevents the attendant from being disturbed by unwanted outside noise.
- The customer's unit has an efficient speaker and a sensitive condenser cartridge, mounted in a beautifully designed housing.
- Attendant's microphone has voice priority over the customer's microphone.
- Power Supply CCS-2300P is BIS approved.



SPECIFICATIONS

CCS-2300

OUTPUT	2W (Max.) in each amplifier
MICROPHONE ELEMENT	Electret Condenser in both the units.
AUTO MUTE 'ON'	Enables after 30 seconds (approx.)
POWER REQUIREMENT	AC: 220-240V, 50/60Hz
PROTECTIONS	AC Fuse 1 × 0.5A
DIMENSIONS	
Attendant Unit	W116 × H65 × D170 mm (w/o gooseneck)
Customer Unit	Ø98 × D52 mm
Power Supply Unit	W85 × H58 × D150 mm
WEIGHT	
Attendant Unit	1.30kg
Customer Unit	480g
Power Supply Unit	930g
ACCESSORIES	1 No. of fuse 0.5A, 2 Nos. of M4 moulded screws, 2 Nos. of self adhesive DUAL LOCK tape, 4.5mtrs. of interconnecting cable for Customer unit

CCS-2200

AC Operation



- Unique design, pleasing aesthetics & rugged construction.
- Duplex communication technology, ideal for ticket counters, enquiry counters, banks, embassies, hospitals etc.,. Wherever two way communication is required across a glass barrier. (Can also be used for one way communication).
- Compact & elegant attendant unit with 406.4 mm (16") long gooseneck microphone, in black colour finish, for flexible sound pickup angle.
- Separate switches for switching the Host Unit mic, or the External Unit mic, ON or OFF.
- Separate volume controls on the Host Unit for adjusting the audio output level of the Host Unit and the External Unit.
- Host Unit mic has automatic voice priority over the External Unit mic. When attendant is speaking into the Host Unit mic, the mic of the External unit is automatically muted.
- Exclusively designed lightweight plastic external unit, which can be easily mounted on any flat surface. Double sided fixing pad provided.
- External unit houses a condenser mic cartridge and an efficient speaker for clear and intelligible sound outside the glass barrier.
- Audio output for recording available through 3.5 mm phone jack on the Host Unit. This is a stereo output having signals from both the Host Unit mic and the External Unit mic.
- A 3.5 mm phone jack is provided on the rear panel of the Host Unit for Line Input. This feature can be used to play back pre-recorded messages through the external unit speaker by connecting the Pre-amp output or Line Output of any Ahuja amplifier to the Line Input of the Host Unit.
- The system is easy to install and simple to operate.
- The Host Unit is a table top unit which operates on 12V DC, through an AC adaptor supplied alongwith.

SPECIFICATIONS	CCS-2200
OUTPUT	2W (Max.) in each amplifier
MICROPHONE ELEMENT	Electret Condenser in both the units
POWER REQUIREMENT	AC: 220-240V, 50/60Hz
PROTECTIONS	4Ω each
DIMENSIONS	
Attendant Unit	W180 × H130 × D57 mm
Customer Unit	W118 × H84 × D39 mm
WEIGHT	
Attendant Unit	590g
Customer Unit	190g
Accessories	1 No. Attendant (Host) Unit, 1 No. Customer (Ext.) Unit, 1 No. AC adaptor, 1 No. self adhesive Tape, 1 No. rubber strip



Microphone and Speaker Stands

MICROPHONE STANDS

AHUJA Microphone stands employ sturdy mechanism ensuring trouble free movement and positioning of microphones. These stands are functional and resistant to corrosion, due to superior quality of chrome plating/powder coating. These stands are with 5/8" 27 TPI to match all AHUJA MICROPHONES.



SPECIFICATIONS	ATS-5	DGT	ATS-200	DGF	DGN	AFS-201	BMS-101
TYPE	Table Stand	Table/Floor Stand	Table/Floor Stand	Floor Stand	Floor Stand	Floor Stand	Boom Stand
HEIGHT	130 mm	350-530 mm	350-530 mm	690-1000 mm	920-1500 mm	920-1500 mm	1000-1700 mm
BASE DIA	120 mm	150 mm	150 mm	230 mm	230 mm	230 mm	650 mm
WEIGHT	760g	2.20kg	2.22kg	3.10kg	4.60kg	4.41kg	2.16kg

SPEAKER STANDS & BRACKETS

Aluminium speaker stands designed for quick and easy installation. Equipped with rigid clamping system. A steel locking pin has been provided in STA-100 and STA-150, which gives secure positioning of elevated equipment. In STR-200, a secure and reliable auto locking arrangement is provided for desired positioning of the equipment. Coated with black powder paint for long life.



SPECIFICATIONS	STA-100	STA-150	STR-200
Height Adjustment	762 mm (2.5') - 1067 mm (3.5')	1067 mm (3.5) - 1981 mm (6.5')	1295 mm (4.25') - 2057 mm (6.75')
LOAD CAPACITY	25.00kg	40.00kg	60.00kg
WEIGHT	3.00kg	4.70kg	4.25kg

ALF-15

Flybar Frame

For ALX-15000M & ALA-9000



INSTALLATION CARE POINTS

1. Installation should be done by an authorised professional only.
2. Inspect the flybar, locking pins, brackets and hardware for any damages prior to rigging & suspending the system.
3. Usage of brackets, locking pins, flybar and hardware, as supplied with the system, is highly recommended.
4. Only competent personnel should be engaged for installation of trusses and flying the line array system.
5. Additional safety items like belts, chains etc. should always be used.

ALF-07

Flybar Frame

For ALX-7500



AWB-30

Wall Mount Bracket



INSTALLATION CARE POINTS

1. Recommended for use with AHUJA Moulded Cabinet PA Loudspeakers.
2. Inspect the locking pins, brackets and hardware for any damages prior to mounting.
3. Installation should be done by an authorised professional only.

CONNECTORS

There are various connectors used with the Ahuja range of PA Products.

1. RCA Phono Plug

A popular audio connector used on auxiliary inputs & booster in/out connections; also commonly used on mixers, CD & tape players. They are wired using single core screened cable.

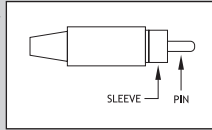

2. XLR Plug

This is the industry standard microphone connector; robust and relatively simple to install. There are a number of ways in which they can be wired.

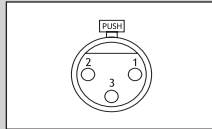

Balanced Operation

- Pin 1 connects to screen (Signal earth)
- Pin 2 connects to signal + (Live)
- Pin 3 connects to signal - (Return)

Quasi Balanced Operation

- Pins 1 & 3 connects to the screen of the cable
- Pin 2 connects to signal conductor.

The Pin numbers are identified on the XLR plug and an easy way to remember how they should be wired is:

- X = Earth (Pin 1)
- L = Live (Pin 2)
- R = Return (Pin 3)

3. 6.3 mm (1/4") Phone Plug

There are two versions of this connector in common use, MONO & STEREO.

The STEREO plug is used for BALANCED operation and wired as follows:

- TIP - Signal +
- RING - Signal -
- SLEEVE - Screen

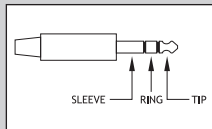

The MONO plug is used for UNBALANCED operation and wired as follows:

- TIP - Signal +
- SLEEVE - Screen

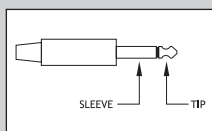

The MONO plug is also used for QUASI-BALANCED operation and is wired as follows:

- TIP - Signal +
- SLEEVE - Signal -, Screen

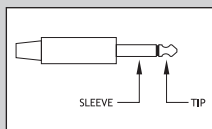

4. SPEAKON Plug

This is used in some models of Ahuja speaker systems for connecting to an amplifier. The pin configurations are as shown in the diagram:

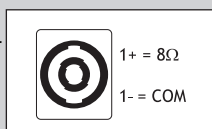

LOUDSPEAKER CABLE SIZE & CONNECTIONS

100V LINE

When installing a 100V line system, it is important that the correct size of cable is used to connect the speakers to the amplifier. The following chart gives an indication of the maximum cable length which can be used for each type of cable (cables specified by number & diameter of wire in mm).

100V Amp	24/0.2	32/0.2	48/0.2	80/0.2	128/0.2	122/0.25
30W	800m	1066m	1600m	2666m	4266m	6400m
60W	400m	533m	800m	1333m	2133m	3200m
120W	200m	266m	400m	666m	1066m	1600m
240W	100m	133m	200m	333m	533m	800m

As the voltage on the line can approach 100 volts, installation must follow best practice with double insulated cable being used. Cable runs should be kept away from any potential source of interference such as 3 phase mains, data, telecom cables etc.

100V Line System must always be wired in PARALLEL:

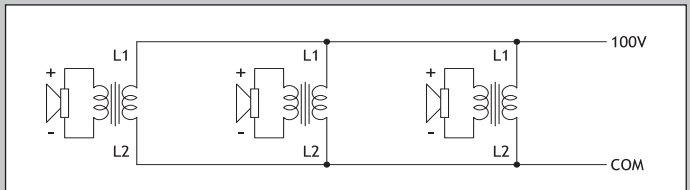

NOTE: The total load presented to the amplifier must not exceed the rated output of the amplifier or damage can result.

LOW IMPEDANCE

All the amplifiers in the Ahuja range have the facility for connection of low impedance loudspeakers. On low impedance, to minimize power losses, short cable runs are recommended. Where it is intended to use multiple low impedance speakers to cover an area, the speakers must be wired in a series/parallel arrangement in such a way to present the correct load to the amplifier.

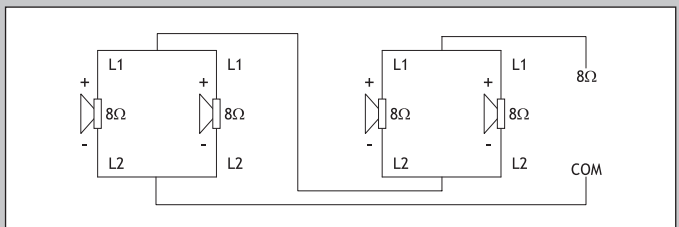

NOTE: The total load impedance presented to the amplifier must never be below the rated amplifier impedance, otherwise damage can result. To avoid damage to the speakers the total wattage of the driver units should be at least 30% higher than the rated power output of the amplifier.

You must NEVER mix 100V line and low impedance speakers on the same system.



PA Fundamentals

IP DEGREES OF PROTECTION

IP protection is given as two figures.
For example: IP66

The 1st numeral (6) - Dust tight. No ingress of dust.

The 2nd numeral (6) - Protected against heavy seas, or water projected in powerful jets shall not enter the enclosure.

1st Numeral: Protection of persons and from solid objects

1		Protected against solid objects greater than 50 mm Ø Can not touch the live part in the enclosure with hand.
2		Protected against solid objects greater than 12 mm Ø Can not touch the live part in the enclosure with finger tip.
3		Protected against solid objects greater than 2.5 mm Ø Can not touch the live part in the enclosure with tools, wires.
4		Protected against solid objects greater than 1.0 mm Ø Can not touch the live part in the enclosure with tools, wire.
5		Dust protected. Ingress of dust is not totally prevented but satisfactory operation of the equipment is available.
6		Dust tight. No ingress of dust.

2nd Numeral: Protection from ingress of water

1		Protected against dripping water.
2		Protected against dripping water when tilted upto 15°.
3		Protected against spraying water at angle up to 60° from the vertical.
4		Protected against splashing water from any direction.
5		Protected against water jets by a nozzle against the enclosure from any direction.
6		Protected against heavy seas or water projected in powerful jets shall not enter the enclosure.
7		Protected against the effects on immersion.
8		Protected against submersion.

KEY TO SYMBOLS USED

	2-Zone Operation		Supercardioid		Two Speakers 12"
	19" Rack Mounting		Omnidirectional		One Speaker 12"
	Telephone Input		IP Rating		Two Way Speaker System
	Headphone Output		100V Line		Subwoofer
	CLASS-D AMPLIFIER		Double Insulated		Compliance to EU Standards
	Unidirectional Cardioid		Weatherproof		New Product

GENERAL INSTALLATION PRECAUTIONS

DO NOT run microphone cables near mains, data, telephone or 100V line cables.

DO NOT run 100V line cables near data, telephone or other low voltage cables.

DO NOT exceed 90% of the amplifier's output power when using 100V line (speech only).

DO NOT exceed 70% of the amplifier's output power when using 100V line (high level music or voice).

DO NOT over-drive the mic inputs. (In certain PA applications an extremely high speech signal is fed to the microphone. This results in a highly distorted output, thereby damaging driver unit/speaker voice coil). For such applications connect the microphone through an attenuator to the amplifier.

ALWAYS keep 'Microphone' Volume Control and 'Master' Volume Control of the Amplifier at position '6' or below.

DO NOT use 100V line and low impedance speaker connections to the same amplifier.

AVOID jointing the microphone cable; when this is unavoidable make sure a good screened connector is used, e.g. XLR.

ENSURE that all loudspeakers are in-phase.

ENSURE that there are no short circuits on the loudspeaker line before connection to the amplifier.

RELATIVE NOISE LEVELS IN Decibels

dB	Comment
120	Threshold of pain. Jet taking off at 60m
115	Pneumatic drill, express train passing through station
110	Impossible to converse. Disco (on dance floor)
105	Live orchestra
100	Inside underground railway station
95	Machine shop, print shop
90	Difficult to converse. Ventilation equipment room, club
85	Busy supermarket
80	Loud voice needed to talk, Traffic noise, church choir
75	Noisy office
70	Speech at 30cm, typing pool, theatre, department store
65	Typical office, normal talking, near motorway
55	Background noise, hotel lobby, restaurant
50	Light traffic at 30m, quiet office
45	Tearing paper at 1m
40	Average residential area, quiet house
35	Soft music
30	Countryside
25	Library
20	Leaves rustling
15	Broadcasting studio
10	Quiet whisper at 1m
0	Threshold of hearing. Minimum audible sound

WARNING

In the market **SPURIOUS/DUPLICATE** sub-standard Amplifiers, Microphones, Driver Units, Horns, Diaphragms are being passed off as genuine AHUJA Products.

BE VERY CAREFUL

- Obtain your requirements from **AUTHORISED AHUJA DEALERS** only.
Insist on seeing the 'AUTHORISED DEALER CERTIFICATE' and **AHUJA** / **ANA** 'TRADE MARK'
- Manufacture & Sale of Spurious/Duplicate Products is Illegal and Punishable Under Law.

INDEX

C

C-1000/450.....	140
C-100HF.....	141
C-1300/750.....	141
C-300/200.....	139
C-350/450.....	139
C-500/450.....	140
C-500/750.....	140
C-600/450.....	140
C-80HF.....	141
CC-125M.....	80
CCS-2200.....	161
CCS-2300.....	160
CDH-200.....	137
CMA-5400.....	12
CMA-7400.....	10
CMC-5100.....	13
CMC-7100.....	11
CMD-5200.....	13
CMD-7200.....	11
CS-3061T.....	92
CS-451T.....	90
CS-5044T.....	91
CS-5061T.....	92
CS-6066T.....	91
CS-6081T.....	92
CS-662T.....	90
CS-663T.....	90
CS-8151T.....	92
CSD-5201T.....	94
CSD-6303T.....	94
CSD-8401T.....	94
CSM-990.....	69
CSX-3081T.....	93
CSX-5081T.....	93
CSX-6101T.....	93
CTP-10DX.....	70
CWM-404U.....	76

D

DA-80.....	38
DA-88.....	38
DCW-8501C.....	9
DCW-8502D.....	9
DCW-8503R.....	8
DCW-8504VP.....	9
DGF.....	162
DGN.....	162
DGT.....	162
Diaphragm HD44-60.....	138
Diaphragm HD51-80.....	138
Diaphragm HD74-120.....	138
DIAPHRAGMS.....	88
DM+2100.....	65
DM-440.....	65
DM-740.....	65
DMX-22.....	62
DMX-44.....	62
DPA-370.....	48
DPA-570M.....	47
DPA-770M.....	47
DX12-F200.....	129
DXA-3502.....	23
DZ12-F200.....	129

E

EHC-10.....	84
EHC-10XT.....	84
EU-70.....	11
EU-85.....	9
EWM-100.....	80

F

FMX-106.....	61
FMX-106DP.....	61
FMX-108DP.....	60
FMX-112DP.....	59
FMX-212PRO.....	58

G

G-611S.....	77
G-622S.....	77
GM-601LM.....	77
GM-605.....	77
GM-611M.....	77
GM-615M.....	77
GMB-6C.....	77
GSX-630T.....	102

H

HBM-50.....	70
HBM-60CC.....	70
HD44-60T.....	137
HD51-80T.....	137
HD74-120.....	137

I

IMPRESS 100T.....	97
IMPRESS 75T.....	97

L

L12-MB200.....	130
L12-MB300.....	130
L12-MB400.....	130
L15-MB300.....	131
L15-MB400.....	131
L15-MB550.....	131
L15-MB700.....	132
L15-MB900.....	132
L18-SW1000.....	133
L18-SW1500.....	134
L18-SW2000.....	134
L18-SW2500.....	135
L18-SW650.....	132
L21-SW3500.....	135
LGM-20.....	9
LMS-408.....	142
LSX-930T.....	102

INDEX

LXA-1400.....	22	PRO-2200SC	65	SRX-200	103
LXA-2000.....	22	PROMIX-1442R.....	54	SRX-220	104
LXA-2400.....	21	PS-300TM.....	99	SRX-250DXM	104
LXA-3200.....	21	PS-400TM.....	99	SRX-260	104
LXA-4500.....	20	PS-500TM.....	99	SRX-440	105
LXA-6000.....	20			SRX-500	105
LXA-7600.....	19			SRX-50DX	103
		S		SRX-50XT.....	103
M		SAX-200DX	107	SRX-510	105
MM-60M.....	80	SAX-300DX	107	SSA-10000.....	30
MMX-55	62	SCM SERIES	88	SSA-100M.....	33
MPA-40S.....	36	SCM-15	88	SSA-160DP.....	45
MTP-20	80	SCM-15T	88	SSA-160EM	32
MX-15	62	SCM-30	88	SSA-250DP.....	45
		SCM-30T	88	SSA-250FX.....	32
N		SGM-40.....	9	SSA-250M.....	32
N12-MB600X	136	SK-12FRX.....	129	SSA-350DP.....	44
N12-MB600Z	136	SK-12FRZ.....	129	SSA-350M.....	31
N18-SW1800.....	136	SK-15FRX.....	129	SSA-5000DP.....	44
NBA-112B.....	156	SK-15FRZ.....	129	SSA-5000EM	31
NBA-15.....	156	SMS-450	113	SSA-7000.....	30
NBA-20DP	156	SMS-450P	114	SSB-120	33
		SP-5251T	100	SSB-120DPM.....	46
O		SP-6305TD	100	SSB-45EM.....	34
OSX-666T	101	SPA-10000	28	SSB-60EM.....	34
OSX-999T	101	SPA-25000	28	SSB-80DFM	46
		SPA-5000EM.....	29	SSB-80M	34
P		SPX-1300.....	109	SSB-85FX	33
PA-200DS	36	SPX-1310.....	110	SSW-16M.....	52
PA-200S	36	SPX-1610.....	110	STA-100	162
PA-400DS	35	SPX-2010.....	111	STA-150	162
PA-400S.....	35	SPX-450	106	STR-200	162
PGB-48.....	79	SPX-550	106	SUB-300A.....	116
PGM-481.....	79	SPX-710	108	SUH-15M	85
PMX-1032DFX.....	56	SPX-800	108	SUH-15MT	86
PMX-1632FX.....	55	SPX-810	109	SUH-25M	85
PRO+ 3200	64	SQX-850.....	107	SUH-25MT	86
PRO+ 3400	64	SRM-120	112	SUH-40.....	85
PRO+ 7500du	64	SRM-220	112	SUH-40XT	86
		SRX-120DXM	103		



SWT-1310.....	119
SWX-1000.....	117
SWX-1010.....	118
SWX-1300DX.....	121
SWX-1510.....	118
SWX-2010.....	120
SWX-2100.....	122
SWX-3100.....	123
SWX-3700N.....	124
SWX-650.....	117

T

THUNDER 1845.....	133
TRINITY-411.....	69
TZA-1500.....	26
TZA-1500DP.....	43
TZA-2000.....	26
TZA-2000DP.....	43
TZA-4000DPM.....	42
TZA-4000EM.....	25
TZA-7000.....	25
TZA-7000DP.....	42

U

UB-30M.....	35
UBA-500DP.....	41
UBA-500M.....	27
UBA-800.....	27
UBA-800DP.....	41
UHC-15.....	85
UHC-15XT.....	86
UHC-25.....	85
UHC-25XT.....	86
UHC-30.....	85
UHC-30XT.....	86
UTP-30.....	70

V

VIVA-600.....	157
VX-200.....	115

VX-300.....	115
VX-400.....	115

W

WFA.....	88
WFB.....	88
WP-225.....	155
WP-225L.....	155
WS-6255TM.....	96
WS-661TM.....	96
WS-664TM.....	96
WSX-551T.....	95
WSX-681T.....	95
WSX-684T.....	95

X

XDA-3002.....	18
XDA-3004.....	16
XDA-5002.....	18
XDA-7002.....	17
XPA-1520DP.....	149

Z

ZXA-500DP.....	40
----------------	----

NOTES

NOTES

NOTES

For Religious Places Outdoor Gatherings Announcements DJs Railway Stations Airports Food Courts Stadiums Auditoriums Hospitals Conferences Offices Shopping Malls Hotels Channel Music High Rise Buildings Parking Lots Restaurants Pubs Schools Gymnasiums Petrol Pumps Stage Shows Coaching Institutes Crowd Control Discourses Paging Sound Professionals and many more



The Most Admired Indian Manufactured Electronics Brand Awarded by ECLINA in 2015 N.S. Ahuja & Sandeep Ahuja receiving the Award



Outstanding Contribution of over 80 years to the Pro Audio Industry Awarded to the Ahuja Family by PALM Expo. in 2022



“ICON of The Industry” Award given to Late Mr. A.N. Ahuja by ESC in March 2025 Sandeep Ahuja & Vikram Ahuja receiving the Award

Design and Specifications are subject to change without notice owing to continuous product up-gradation.

Technical specifications are subject to production tolerances.

We cannot be held responsible for printing errors, should they occur.

AHUJA and **ANA** are registered trademarks of Ahuja Radios in India and other countries.

© Copyright Ahuja Radios, 2026. All rights reserved. Any unauthorized reproduction or use of logos, images or design elements are strictly prohibited by law. No part of the compilation may be reproduced in any manner or translated without written permission.

Ahuja Products manufactured by:

AHUJA RADIOS

215, Okhla Industrial Estate, New Delhi-110 020, India

Tel: +91-11-26831549/41612474 Fax: +91-11-26847287/41616563

E-mail: marketing@ahujaradios.com

For Enquiries (within India): marketing@ahujaradios.com

For International Enquiries (from outside India): intl.trade@ahujaradios.com

AHUJA RADIOS, C-45, Phase-II, Noida-201305 (UP)

TRUSOUND PVT. LTD., C-89, Sector IV, Noida-201301 (UP)

www.ahujaradios.com



An ISO 14001:2015 Company
An ISO/IEC 27001:2013 Company



ACCREDITED
Management System
Certification Body
MSCB-119

An ISO 9001:2015 Company